

Robert Bosch Power Tools GmbH
70538 Stuttgart
GERMANY

www.bosch-pt.com

1 609 92A 4JN (2018.10) AS / 44



1 609 92A 4JN

GDS 18 V-LI HT Professional



- en Original instructions
- zh 正本使用说明书
- zh 原始使用說明書
- ko 사용 설명서 원본
- th หนังสือคู่มือการใช้งานฉบับต้นแบบ
- id Petunjuk-Petunjuk untuk Penggunaan Orisinal
- vi Bản gốc hướng dẫn sử dụng

English	Page	5
中文	页	12
繁體中文	頁	16
한국어	페이지	20
ไทย	หน้า	25
Bahasa Indonesia	Halaman	32
Tiếng Việt	Trang	37

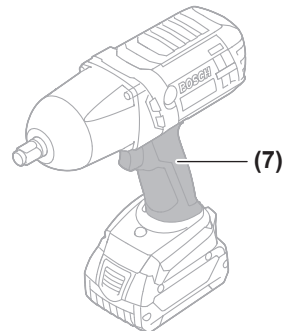
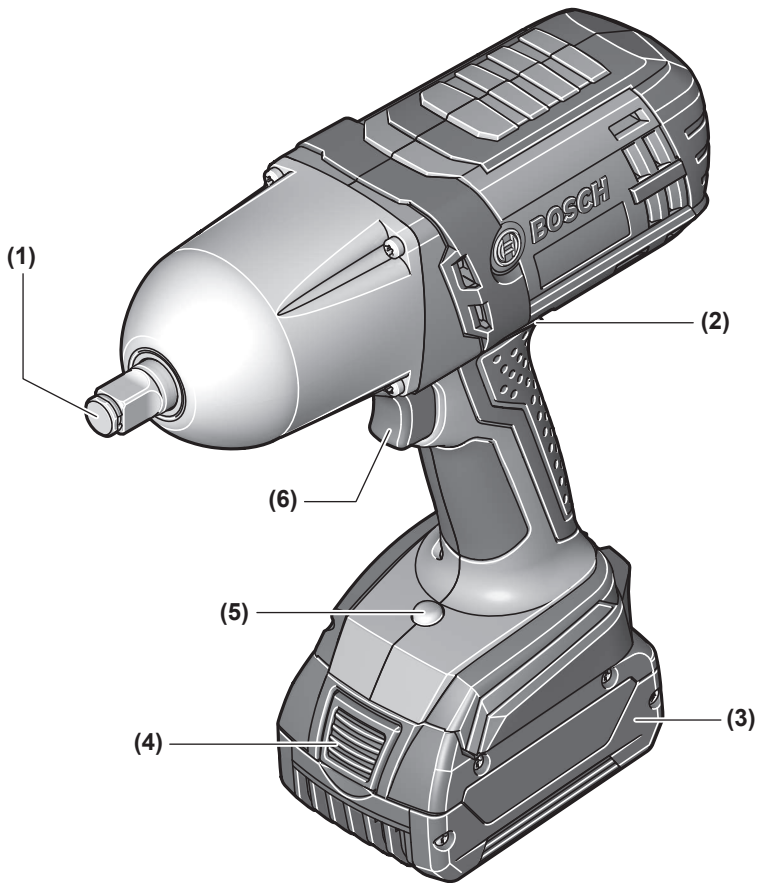

GDS 18 V-LI HT

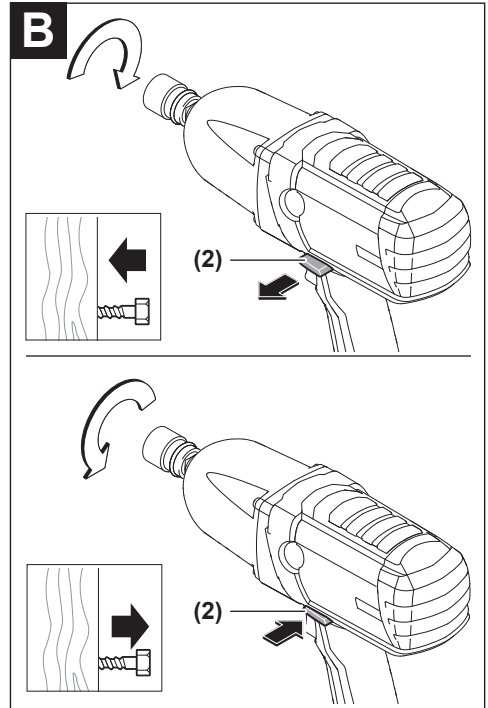
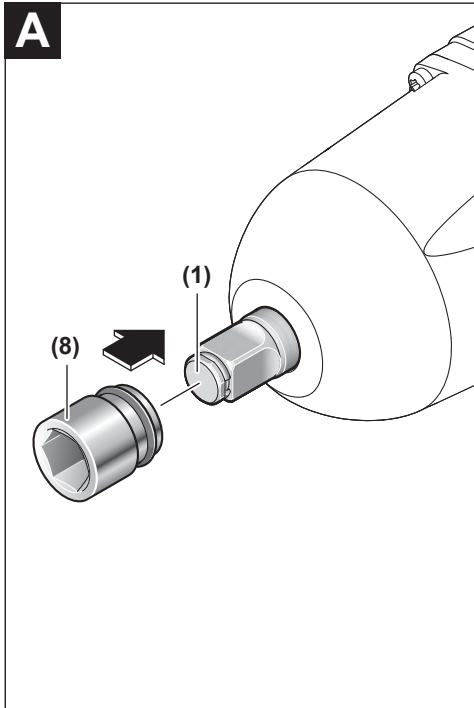

English

Safety instructions

General Power Tool Safety Warnings

⚠ WARNING Read all safety warnings, instructions, illustrations and specifications provided with this power tool. Failure to follow all instructions listed below may result in electric shock, fire and/or serious injury.

Save all warnings and instructions for future reference.

The term "power tool" in the warnings refers to your mains-operated (corded) power tool or battery-operated (cordless) power tool.

Work area safety

- ▶ **Keep work area clean and well lit.** Cluttered or dark areas invite accidents.
- ▶ **Do not operate power tools in explosive atmospheres, such as in the presence of flammable liquids, gases or dust.** Power tools create sparks which may ignite the dust or fumes.
- ▶ **Keep children and bystanders away while operating a power tool.** Distractions can cause you to lose control.

Electrical safety

- ▶ **Power tool plugs must match the outlet. Never modify the plug in any way. Do not use any adapter plugs with earthed (grounded) power tools.** Unmodified plugs and matching outlets will reduce risk of electric shock.
- ▶ **Avoid body contact with earthed or grounded surfaces, such as pipes, radiators, ranges and refrigerators.** There is an increased risk of electric shock if your body is earthed or grounded.
- ▶ **Do not expose power tools to rain or wet conditions.** Water entering a power tool will increase the risk of electric shock.
- ▶ **Do not abuse the cord. Never use the cord for carrying, pulling or unplugging the power tool. Keep cord away from heat, oil, sharp edges or moving parts.** Damaged or entangled cords increase the risk of electric shock.
- ▶ **When operating a power tool outdoors, use an extension cord suitable for outdoor use.** Use of a cord suitable for outdoor use reduces the risk of electric shock.
- ▶ **If operating a power tool in a damp location is unavoidable, use a residual current device (RCD) protected supply.** Use of an RCD reduces the risk of electric shock.

Personal safety

- ▶ **Stay alert, watch what you are doing and use common sense when operating a power tool. Do not use a**

power tool while you are tired or under the influence of drugs, alcohol or medication. A moment of inattention while operating power tools may result in serious personal injury.

- ▶ **Use personal protective equipment. Always wear eye protection.** Protective equipment such as a dust mask, non-skid safety shoes, hard hat or hearing protection used for appropriate conditions will reduce personal injuries.
- ▶ **Prevent unintentional starting. Ensure the switch is in the off-position before connecting to power source and/or battery pack, picking up or carrying the tool.** Carrying power tools with your finger on the switch or energising power tools that have the switch on invites accidents.
- ▶ **Remove any adjusting key or wrench before turning the power tool on.** A wrench or a key left attached to a rotating part of the power tool may result in personal injury.
- ▶ **Do not overreach. Keep proper footing and balance at all times.** This enables better control of the power tool in unexpected situations.
- ▶ **Dress properly. Do not wear loose clothing or jewellery. Keep your hair and clothing away from moving parts.** Loose clothes, jewellery or long hair can be caught in moving parts.
- ▶ **If devices are provided for the connection of dust extraction and collection facilities, ensure these are connected and properly used.** Use of dust collection can reduce dust-related hazards.
- ▶ **Do not let familiarity gained from frequent use of tools allow you to become complacent and ignore tool safety principles.** A careless action can cause severe injury within a fraction of a second.

Power tool use and care

- ▶ **Do not force the power tool. Use the correct power tool for your application.** The correct power tool will do the job better and safer at the rate for which it was designed.
- ▶ **Do not use the power tool if the switch does not turn it on and off.** Any power tool that cannot be controlled with the switch is dangerous and must be repaired.
- ▶ **Disconnect the plug from the power source and/or remove the battery pack, if detachable, from the power tool before making any adjustments, changing accessories, or storing power tools.** Such preventive safety measures reduce the risk of starting the power tool accidentally.
- ▶ **Store idle power tools out of the reach of children and do not allow persons unfamiliar with the power tool or these instructions to operate the power tool.** Power tools are dangerous in the hands of untrained users.
- ▶ **Maintain power tools and accessories. Check for misalignment or binding of moving parts, breakage of parts and any other condition that may affect the power tool's operation. If damaged, have the power**

tool repaired before use. Many accidents are caused by poorly maintained power tools.

- ▶ **Keep cutting tools sharp and clean.** Properly maintained cutting tools with sharp cutting edges are less likely to bind and are easier to control.
- ▶ **Use the power tool, accessories and tool bits etc. in accordance with these instructions, taking into account the working conditions and the work to be performed.** Use of the power tool for operations different from those intended could result in a hazardous situation.
- ▶ **Keep handles and grasping surfaces dry, clean and free from oil and grease.** Slippery handles and grasping surfaces do not allow for safe handling and control of the tool in unexpected situations.

Battery tool use and care

- ▶ **Recharge only with the charger specified by the manufacturer.** A charger that is suitable for one type of battery pack may create a risk of fire when used with another battery pack.
- ▶ **Use power tools only with specifically designated battery packs.** Use of any other battery packs may create a risk of injury and fire.
- ▶ **When battery pack is not in use, keep it away from other metal objects, like paper clips, coins, keys, nails, screws or other small metal objects, that can make a connection from one terminal to another.** Shorting the battery terminals together may cause burns or a fire.
- ▶ **Under abusive conditions, liquid may be ejected from the battery; avoid contact. If contact accidentally occurs, flush with water. If liquid contacts eyes, additionally seek medical help.** Liquid ejected from the battery may cause irritation or burns.
- ▶ **Do not use a battery pack or tool that is damaged or modified.** Damaged or modified batteries may exhibit unpredictable behaviour resulting in fire, explosion or risk of injury.
- ▶ **Do not expose a battery pack or tool to fire or excessive temperature.** Exposure to fire or temperature above 130°C may cause explosion.
- ▶ **Follow all charging instructions and do not charge the battery pack or tool outside the temperature range specified in the instructions.** Charging improperly or at temperatures outside the specified range may damage the battery and increase the risk of fire.

Service

- ▶ **Have your power tool serviced by a qualified repair person using only identical replacement parts.** This will ensure that the safety of the power tool is maintained.
- ▶ **Never service damaged battery packs.** Service of battery packs should only be performed by the manufacturer or authorized service providers.

Safety Warnings for Screwdrivers

- ▶ **Hold the power tool by insulated gripping surfaces, when performing an operation where the fastener may contact hidden wiring.** Fasteners contacting a "live" wire may make exposed metal parts of the power tool "live" and could give the operator an electric shock.
- ▶ **Use suitable detectors to determine if there are hidden supply lines or contact the local utility company for assistance.** Contact with electric cables can cause fire and electric shock. Damaging gas lines can lead to explosion. Breaking water pipes causes property damage.
- ▶ **Hold the power tool securely.** When tightening and loosening screws be prepared for temporarily high torque reactions.
- ▶ **Secure the workpiece.** A workpiece clamped with clamping devices or in a vice is held more secure than by hand.
- ▶ **Always wait until the power tool has come to a complete stop before placing it down.** The application tool can jam and cause you to lose control of the power tool.
- ▶ **In case of damage and improper use of the battery, vapours may be emitted.** Ensure the area is well-ventilated and seek medical attention should you experience any adverse effects. The vapours may irritate the respiratory system.
- ▶ **Do not open the battery.** There is a risk of short-circuiting.
- ▶ **The battery can be damaged by pointed objects such as nails or screwdrivers or by force applied externally.** An internal short circuit may occur, causing the battery to burn, smoke, explode or overheat.
- ▶ **Only use the battery with products from the manufacturer.** This is the only way in which you can protect the battery against dangerous overload.



Protect the battery against heat, e.g. against continuous intense sunlight, fire, water and moisture. There is a risk of explosion.

Product Description and Specifications



Read all the safety and general instructions.

Failure to observe the safety and general instructions may result in electric shock, fire and/or serious injury.

Please observe the illustrations at the beginning of this operating manual.

Intended Use

The machine is intended for driving in and loosening screws and bolts as well as for tightening and loosening nuts within the respective range of dimension.

Product Features

The numbering of the product features refers to the diagram of the power tool on the graphics page.

- (1) Tool holder
- (2) Rotational direction switch
- (3) Battery ^{A)}
- (4) Battery release button ^{A)}
- (5) "PowerLight" lamp
- (6) On/off switch
- (7) Handle (insulated gripping surface)
- (8) Application tool (e.g. screw socket)

A) Accessories shown or described are not included with the product as standard. You can find the complete selection of accessories in our accessories range.

Technical data

Cordless impact screw-driver		GDS 18 V-Li HT
Article number		3 601 JB1 3..
Rated voltage	V =	18
No-load speed	rpm	0–1 900
Impact rate	rpm	0–2 100
Maximum torque, hard screwdriving application according to ISO 5393	Nm	650
Machine screw diameter	mm	M12–M20
Tool holder		■ ½"
Weight according to EPTA-Procedure 01:2014	kg	2.7–3.2 ^{A)}
Permitted ambient temperature		
– during charging	°C	0 ... +45
– during operation ^{B)} and during storage	°C	–20 ... +50
Recommended batteries		GBA 18V.. GBA 18V... W
Recommended chargers		GAL 18...W ^{C)} GAL 18V.. GAX 18V-30 AL 1820 CV AL 1860 CV GAL 1880 CV GAL 3680 CV

A) Depends on battery in use

B) Limited performance at temperatures <0 °C

C) only for inductive batteries

Assembly

- **Remove the battery from the power tool before carrying out work on the power tool (e.g. maintenance, changing tool, etc.). The battery should also be re-**

moved for transport and storage. There is risk of injury from unintentionally pressing the on/off switch.

Battery charging

Note: The battery is supplied partially charged. To ensure full battery capacity, fully charge the battery in the charger before using your power tool for the first time.

The lithium-ion battery can be charged at any time without reducing its service life. Interrupting the charging process does not damage the battery.

The lithium-ion battery is protected against deep discharge by the "Electronic Cell Protection (ECP)". When the battery is discharged, the power tool is switched off by means of a protective circuit: The application tool no longer rotates.

- **Do not continue to press the On/Off switch after the power tool has automatically switched off.** The battery can be damaged.

Battery Charge Indicator

The three green LEDs of the battery charge indicator indicate the state of charge of the battery (3). For safety reasons, it is only possible to check the state of charge when the power tool is not in operation.

Press the button for the battery charge indicator to show the state of charge. This is also possible when the battery (3) is removed.

LED	Capacity
Continuous lighting 3 x green	≥ 2/3
Continuous lighting 2 x green	≥ 1/3
Continuous lighting 1 x green	< 1/3
Flashing light 3 x green	Reserve

If no LED lights up after pressing the button for the battery charge indicator, then the battery is defective and must be replaced.

Removing the battery

The battery (3) is equipped with two locking levels to prevent the battery from falling out when pushing the battery release button (4) unintentionally. As long as the battery is inserted in the power tool, it is held in position by means of a spring.

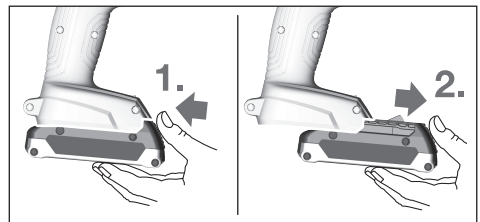

To remove the battery (3), press the release button (4) and pull the battery forward and out of the power tool. **Do not use force to do this.**

Changing the tool (see figure A)

- ▶ **Remove the battery from the power tool before carrying out work on the power tool (e.g. maintenance, changing tool, etc.). The battery should also be removed for transport and storage.** There is risk of injury from unintentionally pressing the on/off switch.
- ▶ **Regularly clean the power tool's air vents.** The motor's fan can draw the dust inside the housing and excessive accumulation of powdered metal may cause electrical hazards.
- ▶ **When working with an application tool, pay attention that the application tool is connected securely to the tool holder.** When the application tool is not securely connected with the tool holder, it can come off during application.

Slide the application tool (8) onto the square drive of the tool holder (1).

Due to the way the system operates, the application tool (8) will move around slightly in the tool holder (1); this has no influence on the function/safety.

Operation

Method of Operation

The tool holder (1) (with the application tool) is driven by an electric motor via a gear and impact mechanism.

The working procedure is divided into two phases:

Screwing in and tightening (impact mechanism in action).

The impact mechanism is activated as soon as the screwed connection runs tight and load is therefore put on the motor. The impact mechanism then converts the power of the motor to steady rotary impacts. When loosening screws or nuts, the process is reversed.

Starting Operation

Inserting the Battery

Set the rotational direction switch (2) to the centre position to protect the power tool from being switched on accidentally.

Push the charged battery (3) into the base of the power tool from the front until the battery is securely locked.

Set the rotational direction (see figure B)

The rotational direction switch (2) is used to change the rotational direction of the power tool. However, this is not possible while the on/off switch (6) is being pressed.

Right rotation: To drive in screws and tighten nuts, press the rotational direction switch (2) through to the left stop.

Left Rotation: To loosen and unscrew screws and nuts, press the rotational direction switch (2) through to the right stop.

Switching on/off

To **start** the power tool, press and hold the on/off switch (6).

The lamp (5) lights up when the on/off switch (6) is lightly or fully pressed, meaning that the work area is illuminated in poor lighting conditions.

To **switch off** the power tool, release the on/off switch (6).

Adjusting the Speed

You can adjust the speed of the power tool when it is on by pressing in the on/off switch (6) to varying extents.

A light pressure on the on/off switch (6) results in a low rotational speed. Increased pressure on the switch causes an increase in speed.

Practical advice

- ▶ **Only apply the power tool to the screw/nut when the tool is switched off.** Rotating tool inserts can slip off.

The torque depends on the impact duration. The maximum achieved torque results from the sum of all individual torques achieved through impact. Maximum torque is achieved after an impact duration of 6–10 seconds. After this duration, the tightening torque increases only minimally. The impact duration is to be determined for each required tightening torque. The tightening torque actually achieved should always be checked with a torque wrench.

Screw applications with hard, spring-loaded or soft seats

When the achieved torques in an impact series are measured during a test and transferred onto a diagram, the result is the curve of a torque characteristic. The height of the curve corresponds to the maximum achievable torque, and the steepness indicates the duration in which this is achieved.

A torque characteristic depends on the following factors:

- Strength properties of the screws/nuts
- Type of backing (washer, disc spring, seal)
- Strength properties of the material being screwed/bolted together
- Lubrication conditions at the screw/bolt connection

Consequently, the following applies in each case:

- A **hard seat** is used for metal-to-metal screw applications that use washers. After a relatively short impact duration, the maximum torque is achieved (steep characteristic curve). An unnecessarily long impact duration only causes damage to the machine.
- A **spring-loaded seat** is used for metal-to-metal screw applications that use spring washers, disc springs, studs or screws/nuts with conical seats. It is also called a spring-loaded seat when extensions are used.
- A **soft seat** is used for screw applications of e.g. metal on wood or screw applications that use lead washers or fibre washers as backing.

For a spring-loaded seat, as well as for a soft seat, the maximum tightening torque is lower than for a hard seat. A much longer impact duration is also required.

Property classes according to DIN 267	Standard screws/bolts					High-strength bolts		
	3.6	4.6	5.6	5.8	6.8	8.8	10.9	12.9
M12	22.6	30	37.6	50	60	80	113	135
M14	36	48	60	79	95	130	180	215
M16	55	73	92	122	147	196	275	330
M18	81	110	135	180	215	290	405	485
M20	115	155	190	255	305	410	580	690

Tips

Before screwing larger, longer screws into hard materials, it is advisable to pre-drill a pilot hole with the core diameter of the thread to approx. 2/3 of the screw length.

Note: Ensure that no metal particles enter the power tool.

After working at a low speed for an extended period, you should operate the power tool at the maximum speed for approximately three minutes without load to cool it down.

Recommendations for optimal handling of the battery

Protect the battery against moisture and water.

Only store the battery within a temperature range of -20 to 50 °C. Do not leave the battery in your car in the summer, for example.

A significantly reduced operating time after charging indicates that the battery has deteriorated and must be replaced. Follow the instructions on correct disposal.

Maintenance and Servicing

Maintenance and cleaning

- ▶ **Remove the battery from the power tool before carrying out work on the power tool (e.g. maintenance, changing tool, etc.). The battery should also be removed for transport and storage.** There is risk of injury from unintentionally pressing the on/off switch.
- ▶ **To ensure safe and efficient operation, always keep the power tool and the ventilation slots clean.**

After-sales Service and Advice on Using Products

Our after-sales service can answer questions concerning product maintenance and repair, as well as spare parts. You can find exploded drawings and information on spare parts at: www.bosch-pt.com

The Bosch product use advice team will be happy to help you with any questions about our products and their accessories.

www.powertool-portal.de, the internet portal for tradespeople and DIY enthusiasts.

In all correspondence and spare parts orders, please always include the 10-digit article number given on the type plate of the product.

Cambodia

Robert Bosch (Cambodia) Co., Ltd
Unit 8BC, GT Tower, 08th Floor, Street 169,
Czechoslovakia Blvd, Sangkat Veal Vong

Khan 7 Makara, Phnom Penh

VAT TIN: 100 169 511

Tel.: +855 23 900 685

Tel.: +855 23 900 660

www.bosch.com.kh

People's Republic of China China Mainland

Bosch Power Tool (China) Co. Ltd.

Bosch Service Center

567, Bin Kang Road

Bin Kang District

Hangzhou, Zhejiang Province

China 310052

Tel.: (0571) 8887 5566 / 5588

Fax: (0571) 8887 6688 x 5566# / 5588#

E-mail: bsc.hz@cn.bosch.com

www.bosch-pt.com.cn

HK and Macau Special Administrative Regions

Robert Bosch Co. Ltd.

21st Floor, 625 King's Road

North Point, Hong Kong

Customer Service Hotline: +852 2101 0235

Fax: +852 2590 9762

E-mail: info@hk.bosch.com

www.bosch-pt.com.hk

India

Bosch Service Center

69, Habibullah Road, (next to PSBB School), T. Nagar

Chennai-600077

Phone: (044) 64561816

Bosch Service Center Rishyamook

85A, Panchkuin Road

New Delhi-110001

Phone: (011) 43166190

Bosch Service Center 79,

Crystal Bldg., Dr. Annie Besant Road, Worli

Mumbai-400018

Phone: (022) 39569936 / (022) 39569959 /

(022) 39569967 / (022) 24952071

Indonesia

PT Robert Bosch

Palma Tower 10th Floor

Jalan RA Kartini II-S Kaveling 6

Pondok Pinang, Kebayoran Lama

Jakarta Selatan 12310

Tel.: (21) 3005-5800

www.bosch-pt.co.id

Malaysia

Robert Bosch Sdn. Bhd. (220975-V) PT/SMY
 No. 8A, Jalan 13/6
 46200 Petaling Jaya
 Selangor
 Tel.: (03) 79663194
 Toll-Free: 1800 880188
 Fax: (03) 79583838
 E-mail: kiathoe.chong@my.bosch.com
 www.bosch-pt.com.my

Pakistan

Robert Bosch Middle East FZE – Pakistan Liaison Office
 2nd Floor Plaza # 10, CCA Block, DHA Phase 5
 Lahore, 54810
 Phone: +92(303)4444311
 E-mail: Faisal.Khan@bosch.com

Philippines

Robert Bosch, Inc.
 28th Floor Fort Legend Towers,
 3rd Avenue corner 31st Street,
 Fort Bonifacio, Global City,
 1634 Taguig City
 Tel.: (632) 8703871
 Fax: (632) 8703870
 www.bosch-pt.com.ph

Singapore

Powerwell Service Centre Ptd Ltd
 Bosch Authorised Service Centre (Power Tools)
 4012 Ang Mo Kio Ave 10, #01-02 TECHplace
 Singapore 569628
 Tel.: 6452 1770
 Fax: 6452 1760
 E-mail: ask@powerwellsc.com
 www.powerwellsc.com
 www.bosch-pt.com.sg

Thailand

Robert Bosch Ltd.
 Liberty Square Building
 No. 287, 11 Floor
 Silom Road, Bangrak
 Bangkok 10500
 Tel.: 02 6393111
 Fax: 02 2384783
 Robert Bosch Ltd., P. O. Box 2054
 Bangkok 10501
 www.bosch.co.th

Bosch Service – Training Centre
 La Salle Tower Ground Floor Unit No.2
 10/11 La Salle Moo 16
 Srinakharin Road
 Bangkaew, Bang Plee
 Samutprakarn 10540
 Tel.: 02 7587555
 Fax: 02 7587525

Vietnam

Branch of Bosch Vietnam Co., Ltd in HCMC
 14th floor, Deutsches Haus, 33 Le Duun
 Ben Nghe Ward, District 1, Ho Chi Minh City
 Tel.: (028) 6258 3690

Fax: (028) 6258 3692 - 6258 3694
 Hotline: (028) 6250 8555
 E-mail: tuvankhachhang-pt@vn.bosch.com
www.bosch-pt.com.vn

Armenia, Azerbaijan, Georgia, Kyrgyzstan, Mongolia, Tajikistan, Turkmenistan, Uzbekistan

TOO "Robert Bosch" Power Tools, After Sales Service
 Rayimbek Ave., 169/1
 050050, Almaty, Kazakhstan
 Service e-mail: service.pt.ka@bosch.com
 Official website: www.bosch.com, www.bosch-pt.com

Bahrain

Hatem Al Juffali Technical Equipment Establishment.
 Kingdom of Bahrain, Setra Highway, Al Aker Area
 Phone: +966126971777-311
 Fax: +97317704257
 E-mail: h.berjas@ejab.com.sa

Egypt

Unimar
 20 Markaz kadmat
 El tagmoa EL Aoul – New Cairo
 Phone: +20 2224 76091-95
 Phone: +20 2224 78072-73
 Fax: +20222478075
 E-mail: adelzaki@unimaregypt.com

Iran

Robert Bosch Iran
 3rd Floor, No 3, Maadiran Building
 Aftab St., Khodami St., Vanak Sq.
 Tehran 1994834571
 Phone: +9821 86092057

Iraq

Sahba Technology Group
 Al Muthana airport road
 Baghdad
 Phone: +9647901906953
 Phone Dubai: +97143973851
 E-mail: bosch@sahbatechnology.com

Jordan

Roots Arabia – Jordan
 Nasser Bin Jameel street, Building 37 Al Rabiah
 11194 Amman
 Phone: +962 6 5545778
 E-mail: bosch@rootsjordan.com

Kuwait

Al Qurain Automotive Trading Company
 Shuwaikh Industrial Area, Block 1, Plot 16, Street 3rd
 P.O. Box 164 – Safat 13002
 Phone: 24810844
 Fax: 24810879
 E-mail: josephkr@aaalmutawa.com

Lebanon

Tehini Hana & Co. S.A.R.L.
 P.O. Box 90-449
 Jdeideh
 Dora-Beirut

Phone: +9611255211
E-mail: service-pt@tehini-hana.com
Libya

El Naser for Workshop Tools
Swanee Road, Alfalah Area
Tripoli
Phone: +218 21 4811184

Oman
Malatan Trading & Contracting LLC
P.O. Box 131
Ruwi, 112 Sultanate of Oman
Phone: +968 99886794
E-mail: malatanpowertools@malatan.net

Qatar

International Construction Solutions W L L
P. O. Box 51,
Doha Phone: +974 40065458
Fax: +974 4453 8585
E-mail: csd@icsdoha.com

Saudi Arabia

Juffali Technical Equipment Co. (JTECO)
Kilo 14, Madinah Road, Al Bawadi District
Jeddah 21431
Phone: +966 2 6672222 Ext. 1528
Fax: +966 2 6676308
E-mail: roland@ejab.com.sa

Syria

Dallal Establishment for Power Tools
P.O. Box 1030
Aleppo
Phone: +963212116083
E-mail: rita.dallal@hotmail.com

United Arab Emirates

Central Motors & Equipment LLC, P.O. Box 1984
Al-Wahda Street – Old Sana Building
Sharjah
Phone: +971 6 593 2777
Fax: +971 6 533 2269
E-mail: powertools@centralmotors.ae

Yemen

Abualrejal Trading Corporation
Sana'a Zubiery St. Front to new Parliament Building
Phone: +967-1-202010
Fax: +967-1-279029
E-mail: tech-tools@abualrejal.com

Ethiopia

Forever plc
Kebele 2,754, BP 4806,
Addis Ababa
Phone: +251 111 560 600
E-mail: foreverplc@ethionet.et

Ghana

C.WOERMANN LTD.
Nsawam Road/Avenor Junction, P.O. Box 1779
Accra Phone: +233 302 225 141

Kenya

Robert Bosch East Africa Ltd
Mpaka Road P.O. Box 856
00606 Nairobi

Nigeria

Robert Bosch Nigeria Ltd.
52–54 Isaac John Street P.O. Box
GRA Ikeja – Lagos

Republic of South Africa

Customer service
Hotline: (011) 6519600
Gauteng – BSC Service Centre
35 Roper Street, New Centre
Johannesburg
Tel.: (011) 4939375
Fax: (011) 4930126
E-mail: bsctools@icon.co.za

KZN – BSC Service Centre

Unit E, Almar Centre
143 Crompton Street
Pinetown
Tel.: (031) 7012120
Fax: (031) 7012446
E-mail: bsc.dur@za.bosch.com

Western Cape – BSC Service Centre

Democracy Way, Prosperity Park
Milnerton
Tel.: (021) 5512577
Fax: (021) 5513223
E-mail: bsc@zsd.co.za

Bosch Headquarters

Midrand, Gauteng
Tel.: (011) 6519600
Fax: (011) 6519880
E-mail: rbsa-hq.pts@za.bosch.com

Tanzania

Diesel & Autoelectric Service Ltd.
117 Nyerere Rd., P.O. Box 70839
Vingunguti 12109, Dar Es Salaam
Phone: +255 222 861 793/794

Australia, New Zealand and Pacific Islands

Robert Bosch Australia Pty. Ltd.
Power Tools
Locked Bag 66
Clayton South VIC 3169
Customer Contact Center
Inside Australia:
Phone: (01300) 307044
Fax: (01300) 307045
Inside New Zealand:
Phone: (0800) 543353
Fax: (0800) 428570
Outside AU and NZ:
Phone: +61 3 95415555
www.bosch-pt.com.au
www.bosch-pt.co.nz

Transport

The contained lithium-ion batteries are subject to the Dangerous Goods Legislation requirements. The batteries are suitable for road-transport by the user without further restrictions.

When shipping by third parties (e.g.: by air transport or forwarding agency), special requirements on packaging and labelling must be observed. For preparation of the item being shipped, consulting an expert for hazardous material is required.

Dispatch battery packs only when the housing is undamaged. Tape or mask off open contacts and pack up the battery in such a manner that it cannot move around in the packaging. Please also observe the possibility of more detailed national regulations.

Disposal



The machine, rechargeable batteries, accessories and packaging should be sorted for environmental-friendly recycling.



Do not dispose of power tools and batteries/rechargeable batteries into household waste!

Only for EU countries:

According to the Directive 2012/19/EU, power tools that are no longer usable, and according to the Directive 2006/66/EC, defective or used battery packs/batteries, must be collected separately and disposed of in an environmentally correct manner.

Battery packs/batteries:

Li-ion:

Please observe the notes in the section on transport (see "Transport", page 12).

中文

安全规章

电动工具通用安全警告

警告！ 警告！ 阅读所有警告和所有说明！ 不遵照以下警告和说明会导致电击、着火和/或严重伤害。

保存所有警告和说明书以备查阅。

在所有下列的警告中术语“电动工具”指市电驱动（有线）电动工具或电池驱动（无线）电动工具。

工作场地的安全

▶ 保持工作场地清洁和明亮。混乱和黑暗的场地会引发事故。

- ▶ 不要在易爆环境，如有易燃液体、气体或粉尘的环境下操作电动工具。电动工具产生的火花会点燃粉尘或气体。
- ▶ 让儿童和旁观者离开后操作电动工具。注意力不集中会使操作者失去对工具的控制。

电气安全

- ▶ 电动工具插头必须与插座相配。绝不能以任何方式改装插头。需接地的电动工具不能使用任何转换插头。未经改装的插头和相配的插座将减少电击危险。
- ▶ 避免人体接触接地表面，如管道、散热片和冰箱。如果你身体接地会增加电击危险。
- ▶ 不得将电动工具暴露在雨中或潮湿环境中。水进入电动工具将增加电击危险。
- ▶ 不得滥用电线。绝不能用电线搬运、拉动电动工具或拔出其插头。使电线远离热源、油、锐边或运动部件。受损或缠绕的软线会增加电击危险。
- ▶ 当在户外使用电动工具时，使用适合户外使用的外接软线。适合户外使用的软线将减少电击危险。
- ▶ 如果在潮湿环境下操作电动工具是不可避免的，应使用剩余电流动作保护器（RCD）。使用RCD可减小电击危险。

人身安全

- ▶ 保持警觉，当操作电动工具时关注所从事的操作并保持清醒。当你感到疲倦，或在有药物、酒精或治疗反应时，不要操作电动工具。在操作电动工具时瞬间的疏忽会导致严重人身伤害。
- ▶ 使用个人防护装置。始终佩戴护目镜。安全装置，诸如适当条件下使用防尘面具、防滑安全鞋、安全帽、听力防护等装置能减少人身伤害。
- ▶ 防止意外起动。确保开关在连接电源和/或电池盒、拿起或搬运工具时处于关断位置。手指放在已接通电源的开关上或开关处于接通时插入插头可能会导致危险。
- ▶ 在电动工具接通之前，拿掉所有调节钥匙或扳手。遗留在电动工具旋转零件上的扳手或钥匙会导致人身伤害。
- ▶ 手不要伸展得太长。时刻注意立足点和身体平衡。这样在意外情况下能很好地控制电动工具。
- ▶ 着装适当。不要穿宽松衣服或佩戴饰品。让衣服、手套和头发远离运动部件。宽松衣服、佩戴或长发可能会卷入运动部件中。
- ▶ 如果提供了与排屑、集尘设备连接的装置，要确保它们连接完好且使用得当。使用这些装置可减少尘屑引起的危险。
- ▶ 即使由于经常使用电动工具而对此非常熟悉，也不要就认为可以高枕无忧而忽略工具的安全规定。粗心大意的行为可能在瞬间就造成严重的伤害。

电动工具使用和注意事项 电动工具使用和注意事项

- ▶ 不要滥用电动工具，根据用途使用适当的电动工具。选用适当设计的电动工具会使你工作更有效、更安全。

- ▶ 如果开关不能接通或关断工具电源，则不能使用该电动工具。如果开关不能接通或关断工具电源，则不能使用该电动工具。
- ▶ 在进行任何调节、更换附件或贮存电动工具之前，必须从电源上拔掉插头和/或使电池盒与工具脱开。这种防护性措施将减少工具意外起动的危险。
- ▶ 将闲置不用的电动工具贮存在儿童所及范围之外，并且不要让不熟悉电动工具或对这些说明不了解的人操作电动工具。电动工具在未经培训的用户手中是危险的。
- ▶ 保养电动工具。检查运动件是否调整到位或卡住，检查零件破损情况和影响电动工具运行的其他状况。如有损坏，电动工具应在使用前修理好。许多事故由维护不良的电动工具引发。
- ▶ 保持切削刀具锋利和清洁。保养良好的有锋利切削刃的刀具不易卡住而且容易控制。
- ▶ 按照使用说明书，考虑作业条件和进行的作业来使用电动工具、附件和工具的刀头等。将电动工具用于那些与其用途不符的操作可能会导致危险。
- ▶ 保持手柄和握持表面干燥、清洁、无油污。在突发情况下，滑溜的手柄和握持表面无法确保安全地握持和控制工具。

电池式工具使用和注意事项

- ▶ 只用制造商规定的充电器充电。将适用于某种电池盒的充电器用到其他电池盒时会发生着火危险。
- ▶ 只有在配有专用电池盒的情况下才使用电动工具。使用其他电池盒会发生损坏和着火危险。
- ▶ 当电池盒不用时，将它远离其他金属物体，例如回形针、硬币、钥匙、钉子、螺钉或其他小金属物体，以防一端与另一端连接。电池端部短路会引起燃烧或火灾。
- ▶ 在滥用条件下，液体会从电池中溅出；避免接触。如果意外碰到了，用水冲洗。如果液体碰到了眼睛，还要寻求医疗帮助。从电池中溅出的液体会发生腐蚀或燃烧。
- ▶ 不要使用损坏的或更改过的电池组或工具。损坏或更改过的电池可能导致不可预料的情况发生，有着火、爆炸或受伤的风险。
- ▶ 不要将电池组或工具暴露于火焰或高温情况下。火焰或超过130°C的温度可能会引起爆炸。
- ▶ 遵守所有充电说明，给电池组或工具充电时不要超出说明中规定的温度范围。错误充电或温度超出规定的范围可能会损坏电池并提高着火的风险。

维修

- ▶ 将电动工具用于那些与其用途不符的操作可能会导致危险。这样将确保所维修的电动工具的安全性。
- ▶ 不要对损坏的电池组进行保养。只能由制造商或授权的服务商进行电池组的维护保养。

针对起子机的安全规章

- ▶ 如果在操作期间，紧固件可能接触暗线，要握住电动工具的绝缘握持面。一旦紧固件接触“带电”导线，可能会使电动工具外露的金属部件“带电”，并使操作员触电。
- ▶ 使用合适的侦测装置侦察隐藏的电线，或者向当地的相关单位寻求支援。接触电线可能引起火灾并让操作者触电。损坏了瓦斯管会引起爆炸。如果水管被刺穿了会导致财物损失。
- ▶ 请紧握电动工具。拧紧和拧松螺丝时可能短时出现高反应扭矩。
- ▶ 固定好工件。使用固定装置或老虎钳固定工件，会比用手持握工件更牢固。
- ▶ 等待电动工具完全静止后才能放下机器。机器上的工具可能在工作中被夹住，而令您无法控制电动工具。
- ▶ 如果充电电池损坏或者未按照规定使用，充电电池中会散发出有毒蒸汽。工作场所必须保持空气流通，如果身体有任何不适必须马上就医。蓄电池散发的蒸汽会刺激呼吸道。
- ▶ 切勿打开充电电池。可能造成短路。
- ▶ 钉子、螺丝刀等尖锐物品或外力作用可能会损坏充电电池。有可能出现内部短路、蓄电池燃烧、发出烟雾、爆炸或过热。
- ▶ 只能将此充电电池用在制造商的产品中。这样才能确保充电电池不会过载。



保护充电电池免受高温（例如长期日照）、火焰、水和湿气的侵害。有爆炸的危险。



产品和性能说明



请阅读所有安全规章和指示。不遵照以下警告和说明可能导致电击、着火和/或严重伤害。

请注意本使用说明书开头部分的图示。

按照规定使用

本电动工具适用于拧入和拧出螺丝，并且可以拧紧和放松规定尺寸内的螺母。

插图上的机件

机件的编号和电动工具详解图上的编号一致。

- (1) 工具夹头
- (2) 正逆转开关
- (3) 充电电池^{A)}
- (4) 充电电池解锁按钮^{A)}
- (5) “PowerLight”灯
- (6) 电源开关
- (7) 手柄（绝缘握柄）
- (8) 安装件（例如螺母起子头）

A) 图表或说明上提到的附件，并不包含在基本的供货范围内。本公司的附件清单中有完整的附件供应项目。

技术参数

充电式冲击钻/起子机		GDS 18 V-LiHT
物品代码		3 601 JB1 3..
额定电压	伏=	18
无负载转速	转/分钟	0-1900
冲击次数	转/分钟	0-2100
根据ISO 5393, 硬垫拧紧的最大扭矩	牛米	650
机械螺栓直径	毫米	M12-M20
工具夹头		■ ½英寸
重量符合 EPTA-Procedure 01:2014	千克	2.7-3.2 ^{A)}
允许的环境温度		
- 充电时	摄氏度	0...+45
- 工作时 ^{B)} 和仓储时功率受限	摄氏度	-20...+50
推荐的充电电池		GBA 18V.. GBA 18V...W
推荐的充电器		GAL 18...W ^{C)} GAL 18V.. GAX 18V-30 AL 1820 CV AL 1860 CV GAL 1880 CV GAL 3680 CV

A) 视所使用的充电电池而定

B) 温度<0 摄氏度时功率受限

C) 仅适用于感应式充电电池

安装

- ▶ 在电动工具上进行任何维护的工作（例如维修，更换工具等等），以及搬运、保存电动工具之前都必须从机器中取出蓄电池。无意间操作开关可能会造成伤害。

为充电电池充电

提示：充电电池在交货时只完成部分充电。首度使用电动工具之前，必须先充足充电电池的电量以确保充电电池的功率。

可以随时为锂离子电池充电，不会缩短电池的使用寿命。如果充电过程突然中断，也不会损坏电池。本锂离子电池配备了电池电子保护装置 "Electronic Cell Protection (ECP)"，可以防止电池过度放电。电池的电量如果用尽了，保护开关会自动关闭电动工具：安装在机器上的工具刀头会停止转动。

- ▶ **电动工具被关闭之后，切勿继续按住起停开关。**否则可能会损坏电池。

电池电量显示

充电电池电量指示灯的三个绿色LED灯显示充电电池(3)的电量。基于安全的顾虑，务必在电动工具静止时才能够检查蓄电池的电量。

按压充电指示灯按键来显示充电电量。也可以在充电电池(3)取下时操作。

LED	容量
3个绿灯持续亮着	≥ 2/3
2个绿灯持续亮着	≥ 1/3
1个绿灯持续亮着	< 1/3
3个绿灯闪烁	备用电量

如果按压充电电量指示灯按键后没有LED灯亮起，则说明充电电池损坏，必须进行更换。

取出充电电池

本充电电池(3)具备双重锁定功能，即使不小心触动了充电电池的解锁按钮(4)，充电电池也不会从机器中掉落下来。只要充电电池安装在电动工具中，就会被弹簧固定在位置上。

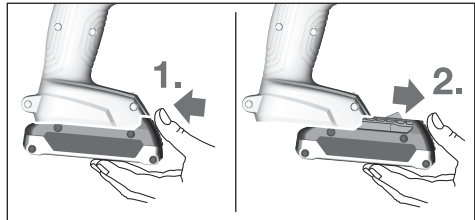

如需取下充电电池(3)，请按压解锁按钮(4)，然后将充电电池向前从电动工具拔出。**在此过程中请勿过度用力。**

更换工具（见图片A）

- ▶ 在电动工具上进行任何维护的工作（例如维修，更换工具等等），以及搬运、保存电动工具之前都必须从机器中取出蓄电池。无意间操作开关可能会造成伤害。
- ▶ 定期清理电动工具的通风口。电机风扇可能将粉尘吸入壳体，大量聚集的粉末状金属可能导致电气危险。
- ▶ 安装工具刀头时请注意务必将其牢牢地插在工具夹头上。如果安装件未牢固地插在工具接头中，可能在拧转螺丝时松脱。

将工具刀头(8)推到工具夹头(1)的四角段上。

由于系统设计原因，工具刀头(8)和工具夹头(1)之间有少许间隙，这不影响电动工具的功能和安全。

运行

功能原理

通过齿轮箱和冲击机构上方的电机驱动工具夹头(1)及工具刀头。

工作过程共分为两个阶段：

拧螺丝和拧紧（冲击机构工作）。

一旦螺丝咬入工件中而且电机承受负荷，冲击机构便投入工作。冲击机构把电机的力转化为均匀的旋转冲击。松开螺丝或螺母时，整个过程以反向进行。

投入使用

安装充电电池

将正逆转开关(2)调至中间位置，以防电动工具意外接通。

将充满电的充电电池(3)从前部推入电动工具脚座中，直至充电电池牢牢锁定。

调整旋转方向 (见图片B)

通过正逆转开关(2)可以更改电动工具的旋转方向。按下起停开关(6)后无法更改。

正转：拧入螺丝并拧紧螺母时，向左按压正逆转开关(2)直至限位。

逆转：松开或拧出螺丝和螺母时，向右按压正逆转开关(2)直至极限位置。

开动/关闭

将电动工具**投入使用**时按压起停开关(6)并按住。轻按或是把起停开关(6)按到底时，灯(5)会亮起，在照明状况不佳的环境中可以借此照亮操作位置。

关闭电动工具时，请松开起停开关(6)。

调整转速

根据按压起停开关(6)的程度，可以无级调节已接通的电动工具的转速。

轻按起停开关(6)，转速低。逐渐在开关上加压，转速也会跟着提高。

工作提示

▶ **先关闭电动工具，然后再放置在螺母/螺栓上。**旋转的工具刀头可能会滑开。

扭矩大小和冲击时间长短有关。最大扭矩是所有通过冲击所产生的单个扭矩的总和。在冲击约6-10秒后，扭矩可以达到最大。超过这段时间，拉紧扭矩只略微增加。

必须测量每个拧紧扭矩的持续冲击时间。总是需要用扭矩扳手检查实际达到的拧紧扭矩。

使用硬垫、弹簧垫或软垫拧转

如果尝试测量一个冲击过程中达到的各个扭矩并记载在一张图表上，可以得到扭矩变化的曲线。曲线的最高点是可达到的最大扭矩，上升的线段则代表到达最大扭矩所需的时间。

扭矩曲线的走向受以下因素影响：

- 螺丝/螺母的强度
- 垫片的种类（螺片，冠状弹簧，密封片）
- 即将被拧入螺丝的物料的强度
- 螺丝是否涂抹了润滑油

综合以上因素，大概可以归类出下列的工作状况：

- **硬垫拧转**，是指在使用垫片的前提下把金属螺栓拧入金属物料中。经过短暂的冲击之后便可以到达最大扭矩（比较陡的上升曲线）。不必要的延长冲击时间只会损坏机器。
- **弹簧垫拧转**，是指在使用了弹簧圈、冠状弹簧、螺栓、带圆锥座的螺栓/螺母以及延长零件等的情况下把金属螺丝拧入金属物料中。
- **软垫拧转**，以下几个例子都属于软垫拧转：把金属螺栓拧入木材中，或者拧紧螺丝时使用了铅垫片、纤维垫片。

弹簧垫拧转和软垫拧转的最大扭矩小于硬垫拧转的最大扭矩。而且前者需要的冲击时间却明显超越后者。

强度等级根据DIN 267 标准螺丝	高强度螺丝							
	3.6	4.6	5.6	5.8	6.8	8.8	10.9	12.9
M12	22.6	30	37.6	50	60	80	113	135
M14	36	48	60	79	95	130	180	215
M16	55	73	92	122	147	196	275	330
M18	81	110	135	180	215	290	405	485
M20	115	155	190	255	305	410	580	690

建议

把大的、长的螺丝拧入坚硬的物料中之前，必须根据螺纹的中心直径预钻孔，预钻孔的深度大概为螺丝长度的2/3。

提示：注意不要让金属小零件进入电动工具。

使用低转速长时间操作之后，应该让电动工具以最大转速空转约3分钟来帮助机器冷却。

正确使用充电电池的提示

充电电池应防潮、防水。

充电电池必须储存在-20 °C至50 °C的环境中。夏天不得将充电电池搁置在汽车中。

充电后如果充电电池的使用时间明显缩短，代表充电电池已经损坏，必须更换新的充电电池。

请注意有关废弃处理的规定。

维修和服务

保养和清洁

- ▶ **在电动工具上进行任何维护的工作（例如维修，更换工具等等），以及搬运、保存电动工具之前都必须从机器中取出蓄电池。**无意间操作开关可能会造成伤害。
- ▶ **电动工具和通气孔必须随时保持清洁，以确保工作效率和工作安全。**

客户服务和应用咨询

本公司顾客服务处负责回答有关本公司产品的修理、维护和备件的问题。备件的分解图和信息也可查看：www.bosch-pt.com
博世应用咨询团队乐于就我们的产品及其附件问题提供帮助。

www.powertool-portal.de, 适合工匠和DIY者的互联网门户网站。

如需查询和订购备件, 请务必提供产品型号铭牌上的10位数货号。

香港和澳门特别行政区

罗伯特博世有限公司
香港北角英皇道625号,
21楼

客户服务热线: +852 2101 0235

传真: +852 2590 9762

电子邮件: info@hk.bosch.com

www.bosch-pt.com.hk

中国大陆

博世电动工具(中国)
有限公司, 中国浙江省杭州市
滨江区滨康路567号
102/1F服务中心
邮政编码: 310052

电话: (0571) 8887 5566 / 5588

传真: (0571) 8887 6688 x 5566# / 5588#

电邮: bsc.hz@cn.bosch.com

中华人民共和国

中国大陆

博世电动工具(中国)有限公司
博世服务中心
中国浙江省杭州市
滨江区
滨康路567号,
310052

电话: (0571) 8887 5566 / 5588

传真: (0571) 8887 6688 x 5566# / 5588#

电子邮件: bsc.hz@cn.bosch.com

www.bosch-pt.com.cn

搬运

随着机器一起供货的锂离子充电电池必须符合危险物品法规。使用者无须另外使用保护包装便可以运送该充电电池。

但是如果将它交由第三者运送(例如: 空运或委托运输公司)则使用特殊的包装和标示。此时必须向危险物品专家请教有关寄送危险物品的相关事宜。

确定充电电池的外壳未受损后, 才可以寄送充电电池。粘好未加盖的触点并包装好充电电池, 不可以让充电电池在包装中晃动。必要时也得注意各国有关的法规。

处理废弃物



必须以符合环保的方式, 回收再利用损坏的电动工具、充电电池、附件和废弃的包装材料。



不可以把电动工具和充电电池/蓄电池丢入一般的家庭垃圾中!

仅适用于欧盟国家:

无法再使用的电动工具根据欧盟第2012/19/EU号指令, 损坏的或旧充电电池/蓄电池根据欧盟第

2006/66/EC号指令必须单独收集并根据环保要求进行处理回收利用。

充电电池/蓄电池:

锂离子:

请注意“搬运”段落中的指示(参见“搬运”, 页16)。

繁體中文

安全注意事項

電動工具一般安全注意事項

警告 請詳讀工作臺及電動工具的所有安全警告與使用說明。若不遵照以下列出的指示, 將可能導致電擊、著火和/或人員重傷。

保存所有警告和說明書以備查閱。

在所有警告中, 「電動工具」此一名詞泛指: 以市電驅動的(有線)電動工具或是以電池驅動的(無線)電動工具。

工作場地的安全

- ▶ **保持工作場地清潔和明亮。** 混亂和黑暗的場地會引發事故。
- ▶ **不要在易爆環境, 如有易燃液體、氣體或粉塵的環境下操作電動工具。** 電動工具產生的火花會點燃粉塵或氣體。
- ▶ **讓兒童和旁觀者離開後操作電動工具。** 注意力不集中會使您失去對工具的控制。

電氣安全

- ▶ **電動工具插頭必須與插座相配。** 絕不能以任何方式改裝插頭。需接地的電動工具不能使用任何轉換插頭。未經改裝的插頭和相配的插座將減少電擊危險。
- ▶ **避免人體接觸接地表面, 如管道、散熱片和冰箱。** 如果您身體接地會增加電擊危險。
- ▶ **不得將電動工具暴露在雨中或潮濕環境中。** 水進入電動工具將增加電擊危險。
- ▶ **不得濫用電線。** 絕不能用電線搬運、拉動電動工具或拔出其插頭。使電線遠離熱源、油、銳利邊緣或移動零件。受損或纏繞的軟線會增加電擊危險。
- ▶ **當在戶外使用電動工具時, 使用適合戶外使用的延長線。** 適合戶外使用的軟線, 將減少電擊危險。
- ▶ **如果在潮濕環境下操作電動工具是不可避免的, 應使用剩餘電流動作保護器(RCD)。** 使用RCD可降低電擊危險。

人身安全

- ▶ **保持警覺，當操作電動工具時關注所從事的操作並保持清醒。當您感到疲倦，或在有藥物、酒精或治療反應時，不要操作電動工具。**在操作電動工具時瞬間的疏忽會導致嚴重人身傷害。
- ▶ **使用個人防護裝置。始終佩戴護目鏡。**安全裝置，諸如適當條件下使用防塵面具、防滑安全鞋、安全帽、聽力防護等裝置能減少人身傷害。
- ▶ **防止意外起動。確保開關在連接電源和 / 或電池盒、拿起或搬運工具時處於關閉位置。**手指放在已接通電源的開關上或開關處於接通時插入插頭可能會導致危險。
- ▶ **在電動工具接通之前，拿掉所有調節鑰匙或扳手。**遺留在電動工具旋轉零件上的扳手或鑰匙會導致人身傷害。
- ▶ **手不要伸展得太長。時刻注意立足點和身體平衡。**這樣在意外情況下能很好地控制電動工具。
- ▶ **著裝適當。不要穿寬鬆衣服或佩戴飾品。**讓您的衣物及頭髮遠離運動部件。寬鬆衣服、佩飾或長髮可能會捲入運動部件中。
- ▶ **如果提供了與排屑、集塵設備連接用的裝置，要確保他們連接完好且使用得當。**使用這些裝置可減少塵屑引起的危險。
- ▶ **切勿因經常使用工具所累積的熟練感而過度自信，輕忽工具的安全守則。**任何一個魯莽的舉動都可能瞬間造成人員重傷。

電動工具使用和注意事項

- ▶ **不要濫用電動工具，根據用途使用適當的電動工具。**選用適當設計的電動工具會使您工作更有效、更安全。
- ▶ **如果開關不能開啟或關閉工具電源，則不能使用該電動工具。**不能用開關來控制的電動工具是危險的且必須進行修理。
- ▶ **在進行任何調整、更換配件或貯存電動工具之前，必須從電源上拔掉插頭並 / 或取出電池盒。**這種防護性措施將減少工具意外起動的危險。
- ▶ **將閒置不用的電動工具貯存在兒童所及範圍之外，並且不要讓不熟悉電動工具或對這些說明不瞭解的人操作電動工具。**電動工具在未經培訓的用戶手中是危險的。
- ▶ **保養電動工具與配備。檢查運動件是否調整到位或卡住，檢查零件破損情況和影響電動工具運行的其他狀況。**如有損壞，電動工具應在使用前修理好。許多事故由維護不良的電動工具引發。
- ▶ **保持切削刀具鋒利和清潔。**保養良好的有鋒利切削刃的刀具不易卡住而且容易控制。
- ▶ **按照使用說明書，考慮作業條件和進行的作業來使用電動工具、配件和工具的刀頭等。**將電動工具用於那些與其用途不符的操作可能會導致危險。
- ▶ **把手及握持區應保持乾燥、潔淨，且不得沾染任何油液或油脂。**易滑脫的把手及握持區將無法讓您在發生意外狀況時安全地抓緊並控制工具。

電池式工具使用和注意事項

- ▶ **只用製造商規定的充電器充電。**將適用於某種電池盒的充電器用到其他電池盒時會發生著火危險。
- ▶ **只有在配有專用電池盒的情況下才使用電動工具。**使用其他電池盒會發生損壞和著火危險。
- ▶ **當電池盒不用時，將它遠離其他金屬物體，例如回形針、硬幣、鑰匙、釘子、螺絲或其他小金屬物體，以防一端與另一端連接。**電池端部短路會引起燃燒或火災。
- ▶ **在濫用條件下，液體會從電池中濺出；避免接觸。如果意外碰到了，用水沖洗。如果液體碰到了眼睛，還要尋求醫療幫助。**從電池中濺出的液體會發生腐蝕或燃燒。
- ▶ **請勿使用已受損或經改裝的電池盒。**已受損或經改裝的電池組可能出現無法預期的反應，進而導致著火、爆炸或造成人員受傷。
- ▶ **勿讓電池盒或工具靠近火源或暴露於異常溫度環境中。**若是靠近火源或暴露在超過 130 °C 的環境中可能造成爆炸。
- ▶ **請完全遵照所有的充電說明，電池盒或工具的溫度若是超出指示的規定範圍，請勿進行充電。**不當充電或是在未規定的溫度範圍內進行充電，皆可能造成電池損壞並面臨更高的著火風險。

檢修

- ▶ **將您的電動工具送交專業維修人員，必須使用同樣的備件進行更換。**這樣將確保所維修的電動工具的安全性。
- ▶ **請勿自行檢修受損的電池盒。**電池組應交由製造商或是獲得授權的服務供應商來進行檢修。

起子機安全注意事項

- ▶ **進行作業時，固定釘可能會碰觸到隱藏的配線，請從絕緣處把處拿持電動工具。**固定釘接觸到「導電」電線可能導致電動工具外露的金屬部件「導電」，進而使操作人員遭受電擊。
- ▶ **使用合適的偵測裝置偵察隱藏的電線，或者向當地的相關單位尋求支援。**接觸電線可能引起火災並讓操作者觸電。若損壞瓦斯管會引起爆炸。如果水管被刺穿會導致財物損失。
- ▶ **請牢牢握緊電動工具。**旋緊與鬆開螺栓時，瞬間可能會有較大的反作用力。
- ▶ **固定好工件。**使用固定裝置或老虎鉗固定工件，會比用手持握工件更牢固。
- ▶ **必須等待電動工具完全靜止後才能將它放下。**嵌件工具可能卡住而使電動工具失控。
- ▶ **如果充電電池損壞了，或者未按照規定使用充電電池，充電電池中會散發出有毒蒸氣。**工作場所必須保持空氣流通，如果身體有任何不適必須馬上就醫。充電電池散發的蒸氣會刺激呼吸道。
- ▶ **切勿拆開充電電池。**可能造成短路。
- ▶ **尖銳物品（例如釘子或螺絲起子）或是外力皆有可能造成充電電池損壞。**進而導致內部短路而發生電池起火、冒煙、爆炸或過熱等事故。
- ▶ **僅可使用產品的原廠充電電池。**如此才可依照產品提供過載保護。



保護充電電池免受高溫（例如長期日照）、火焰、水液和濕氣的侵害。有爆炸的危險。



產品和功率描述

請詳讀所有安全注意事項和指示。如未遵守安全注意事項與指示，可能導致火災、人員遭受電擊及 / 或重傷。

請留意操作說明書中最前面的圖示。



依規定使用機器

本電動工具適用於旋緊和鬆開螺栓，並且可以旋緊和鬆開規定尺寸內的螺母。

插圖上的機件

機件的編號和電動工具詳解圖上的編號一致。

- (1) 工具夾頭
- (2) 正逆轉開關
- (3) 充電電池 ^{A)}
- (4) 充電電池的解鎖按鈕 ^{A)}
- (5) 「PowerLight」照明燈
- (6) 起停開關
- (7) 把手（絕緣握柄）
- (8) 嵌件工具（例如起子頭套筒）

A) 圖表或說明上提到的配件，並不包含在基本的供貨範圍中。本公司的配件清單中有完整的配件供應項目。

技術性數據

充電式衝擊鑽 / 起子機	GDS 18 V-Li HT	
產品機號	3 601 JB1 3..	
額定電壓	V=	18
無負載轉速	次 / 分	0-1 900
衝擊次數	次 / 分	0-2 100
根據 ISO 5393, 硬材料鎖螺絲的最大扭力	Nm	650
機器螺栓直徑	mm	M12-M20
工具夾頭		■ ½"
重量符合 EPTA-Procedure 01:2014	kg	2.7-3.2 ^{A)}
容許環境溫度		
- 充電狀態下	°C	0... +45
- 操作狀態下 ^{B)} 以及存放狀態下	°C	-20... +50
建議使用的充電電池	GBA 18V.. GBA 18V...W	
建議使用的充電器	GAL 18...W ^{C)} GAL 18V.. GAX 18V-30 AL 1820 CV AL 1860 CV	

充電式衝擊鑽 / 起子機

GDS 18 V-Li HT

GAL 1880 CV

GAL 3680 CV

- A) 視所使用的充電蓄電池而定
- B) 溫度 <0 °C 時，性能受限
- C) 僅適用於感應式充電電池

安裝

▶ 在電動工具上進行任何維護的工作（例如維修，更換工具等）以及搬運和儲存電動工具之前，都必須電動工具中取出充電電池。若是不小心觸動起停開關，可能造成人員受傷。

為充電電池進行充電

提示：出貨時充電電池已部分充電。首度使用電動工具之前，請先用充電器將充電電池充飽電以確保充電電池蓄滿電力。

鋰離子充電電池可隨時充電，不會縮短電池的使用壽命。如果突然中斷充電，電池也不會損壞。

鋰離子充電電池配備了電池保護裝置「Electronic Cell Protection (ECP)」，可以防止充電電池過度放電。充電電池的電量如果用盡了，保護開關會自動關閉電動工具：嵌件工具會停止轉動。

▶ 電動工具自動關機後，請勿再按壓電源開關。否則充電電池可能會損壞。

充電電池的電量顯示器

充電電池的電量顯示器有三顆綠色 LED 燈，代表充電電池 (3) 目前的電量。基於安全的顧慮，務必在電動工具靜止時才能夠檢查充電電池的電量。

按一下電量顯示按鈕，即可顯示目前電量。即使已取出充電電池 (3)，此項功能仍可正常運作。

LED	容量
3 顆綠燈持續亮起	≥ 2/3
2 顆綠燈持續亮起	≥ 1/3
1 顆綠燈持續亮起	< 1/3
3 顆綠燈閃爍	備用電量

按壓電量顯示按鈕後，LED 燈若未亮起，即表示充電電池故障，必須予以更換。

取出充電電池

本充電電池 (3) 具備了雙重鎖定功能，即使不小心按壓了充電電池的解鎖按鈕 (4)，充電電池也不會從機器中掉落出來。固定彈簧會把充電電池夾緊在機器中。

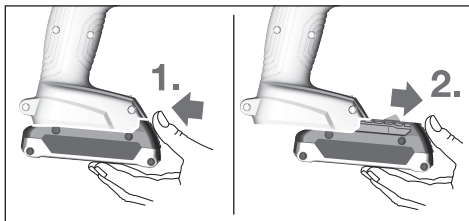

若要取出充電電池 (3)，請按壓解鎖按鈕 (4)，然後將充電電池往前拔出電動工具。**不可以強行拉出充電電池。**

更換工具 (請參考圖 A)

- ▶ 在電動工具上進行任何維護的工作 (例如維修, 更換工具等) 以及搬運和儲存電動工具之前, 都必須電動工具中取出充電電池。若是不小心觸動起停開關, 可能造成人員受傷。
- ▶ 請定期清理電動工具的通風口。馬達風扇會將粉塵捲入機殼內, 累積過多的金屬粉塵可能危及電氣安全。
- ▶ 裝入嵌件工具時務必確認它是否牢牢地固定在工具夾頭上。嵌件工具若未牢固地插在工具夾頭中, 可能會在轉動螺栓時鬆脫。

請將嵌件工具 (8) 推至工具夾頭 (1) 的方形接頭上。

視系統而定, 嵌件工具 (8) 裝到工具夾頭 (1) 上後, 也許仍會有些間隙; 但這並不影響功能運作或工具機的安全性。

操作

運作原理

工具夾頭 (1) 裝上嵌件工具後, 是由電動馬達透過齒輪裝置及撞擊裝置進行驅動。

運作流程分為兩個階段:

旋入和旋緊 (撞擊裝置同時運作)。

當螺絲一咬入工件中且馬達開始負載時, 撞擊裝置便開始運作。撞擊裝置把馬達的傳動力轉換為均勻的旋轉式敲擊動作。鬆開螺栓或螺母時, 整個運作過程是反向進行。

操作機器

安裝充電電池

將正逆轉開關 (2) 移至中間位置, 以防止電動工具意外啟動。

請將充好電的充電電池 (3) 從前方推入電動工具底座, 讓充電電池確實卡上。

調整旋轉方向 (請參考圖 B)

透過正逆轉開關 (2) 即可變更電動工具的旋轉方向。但按下起停開關 (6) 時, 將無法這樣做。

正轉: 若要旋入螺栓及旋緊螺母, 請將正逆轉開關 (2) 往左推到底。

逆轉: 若要鬆開或旋出螺栓與螺母, 請將正逆轉開關 (2) 往右推到底。

啟動 / 關閉

按下電源開關 (6) 不要放開, 即可讓電動工具持續運轉。

輕按起停開關 (6) 或完全按下時, 照明燈 (5) 隨即亮起, 可照亮光線不足的工作區域。

放開起停開關 (6), 即可讓電動工具停止運轉。

調整轉速

您可為已啟動的電動工具無段調控轉速, 轉速是由按壓起停開關 (6) 的深度而定。

輕按起停開關 (6) 時, 轉速較低。逐漸在開關上加壓, 轉速也會跟著提高。

作業注意事項

- ▶ 電動工具應先停止運轉, 然後才放到螺母 / 螺栓上。轉動中的嵌件工具可能會滑開。

扭力大小和衝擊時間長短有關。最大扭矩是所有經由衝擊所產生的單一扭力的總和。衝擊時間持續 6 至 10 秒鐘後, 即達到最大扭矩。超過這段時間, 旋緊扭力只輕微增加。

必須測量每個旋緊扭力的持續衝擊時間。隨時以扭力扳手, 檢查實際達到的旋緊扭力。

硬底旋接、彈性底旋接或軟底旋接

如果將每次衝擊時達到的扭力測量出來並記錄在圖表上, 可以看到扭力變化曲線。曲線的最高點是最大扭矩。上升線段即為到達最大扭矩所須的時間。

扭力曲線的演變會受以下因素影響:

- 螺栓 / 螺母的強度
- 墊片的種類 (圓形墊片、碟形彈簧、密封件)
- 即將被旋入之底材強度
- 螺栓是否塗抹了潤滑油

綜合以上因素, 大致可以歸類出下列的應用方式:

- **硬底旋接**指的是在使用墊片的前提下, 將金屬螺栓鎖到金屬材料上。經過短暫的衝擊之後便可以達到最大扭矩 (比較陡的上升曲線)。不必要的延長衝擊時間只會損壞機器。
- **彈性底旋接**指的是在使用彈簧圈、碟形彈簧、無頭螺絲或帶圓錐座的螺栓 / 螺母以及延長零件等的情況下, 將金屬螺栓鎖到金屬材料上。
- **軟底旋接**, 像是將金屬螺栓鎖到木材上或者是使用鉛質墊片或纖維墊片。

彈性底旋接和軟底旋接的最大扭力小於硬底旋接的最大扭力。而且前者需要的衝擊時間明顯超越後者。

強度等級符合 DIN 267	標準螺栓				高強度螺栓			
	3.6	4.6	5.6	5.8	6.8	8.8	10.9	12.9
M12	22.6	30	37.6	50	60	80	113	135
M14	36	48	60	79	95	130	180	215
M16	55	73	92	122	147	196	275	330
M18	81	110	135	180	215	290	405	485
M20	115	155	190	255	305	410	580	690

建議

將較大、較長螺栓旋入堅硬材質之前，應先以螺紋孔底徑預鑽孔至 2/3 螺栓長度。

提示：不得有任何微小金屬物跑進電動工具內部。使用低轉速長期操作之後，應該讓電動工具以最大轉速空轉約 3 分鐘來幫助機器冷卻。

如何正確地使用充電電池

妥善保護充電電池，避免濕氣和水分滲入。充電電池必須儲存在 -20 °C 至 50 °C 的環境中。夏天不可以把充電電池擱置在汽車中。充電後如果充電電池的使用時間明顯縮短，代表充電電池已經損壞，必須更換新的充電電池。請您遵照廢棄物處理相關指示。

維修和服務**保養與清潔**

- ▶ 在電動工具上進行任何維護的工作（例如維修，更換工具等）以及搬運和儲存電動工具之前，都必須電動工具中取出充電電池。若是小心觸動起停開關，可能造成人員受傷。
- ▶ 電動工具和通風口都必須保持清潔，這樣才能夠提高工作品質和安全性。

顧客服務處和顧客諮詢中心

本公司顧客服務處負責回答有關本公司產品的維修、維護和備用零件的問題。如需分解圖和備件的資料，請至以下網頁：www.bosch-pt.com

若對本公司產品及其配件有任何疑問，博世應用諮詢小組很樂意為您提供協助。

工匠與 DIY 玩家網路平台入口：www.powertool-portal.de

當您需要諮詢或訂購備用零件時，請務必提供本產品銘牌上的 10 位零件編號。

台灣

台灣羅伯特博世股份有限公司

建國北路一段90 號6 樓

台北市10491

電話：(02) 2515 5388

傳真：(02) 2516 1176

www.bosch-pt.com.tw

製造商地址：

Robert Bosch Power Tools GmbH

羅伯特·博世電動工具有限公司

70538 Stuttgart / GERMANY

70538 斯圖加特 / 德國

搬運

隨貨附上的鋰離子充電電池受危險物品法的規範。使用者無須另外使用保護包裝便可運送該充電電池。

但是如果將它交由第三者運送（例如：寄空運或委託運輸公司），則應遵照包裝與標示的相關要求。此時必須向危險物品專家請教有關寄送危險物品的相關事宜。

確定充電電池的外殼未受損後，才可以寄送充電電池。用膠帶貼住裸露的接點並妥善包裝充電電池，不可以讓充電電池在包裝材料中晃動。同時也應留意各國相關法規。

廢棄物處理

必須以符合環保的方式，將損壞的電動工具、充電電池、配件和包裝材料進行回收再利用。



不可以把電動工具和充電電池 / 拋棄式電池丟入一般家庭垃圾中！

僅適用於歐盟國家：

依據歐盟指令 2012/19/EU，無法再繼續使用的電動工具必須分別收集起來，然後遵照環保相關法規進行資源回收。而歐盟指令 2006/66/EC 中則要求已故障或汰換下來的充電電池 / 一般電池亦須比照辦理。

充電電池 / 拋棄式電池：**鋰離子：**

請注意「搬運」段落中的指示（參見「搬運」，頁 20）。

한국어**안전 수칙****전동공구 일반 안전 수칙**

⚠ 경고 본 전동공구와 함께 제공된 모든 안전경고, 지시사항, 그림 및 사양을 숙지하십시오. 다음의 지시 사항을 준수하지 않으면 감전, 화재, 또는 심각한 부상을 초래할 수 있습니다.

앞으로 참고할 수 있도록 이 안전수칙과 사용 설명서를 잘 보관하십시오.

다음에서 사용되는 "전동공구"라는 개념은 전원에 연결하여 사용하는 (전선이 있는) 전동 기기나 배터리를 사용하는 (전선이 없는) 전동 기기를 의미합니다.

작업장 안전

- ▶ 작업장을 항상 깨끗이 하고 조명을 밝게 하십시오. 작업장 환경이 어수선하거나 어두우면 사고를 초래할 수 있습니다.
- ▶ 가연성 유체, 가스 또는 분진이 있어 폭발 위험이 있는 환경에서 전동공구를 사용하지 마십시오. 전동공구는 분진이나 증기에 점화하는 스파크를 일으킬 수 있습니다.
- ▶ 전동공구를 사용할 때 구경꾼이나 어린이 혹은 다른 사람이 작업장에 접근하지 못하게 하십시오.

오. 다른 사람이 주의를 산만하게 하면 기기에 대한 통제력을 잃기 쉽습니다.

전기에 관한 안전

- ▶ **전동공구의 전원 플러그가 전원 콘센트에 잘 맞아야 합니다.** 플러그를 절대 변경시켜서는 안 됩니다. (접지된) 전동공구를 사용할 때 어댑터 플러그를 사용하지 마십시오. 변경되지 않은 플러그와 잘 맞는 콘센트를 사용하면 감전의 위험을 줄일 수 있습니다.
- ▶ **파이프 관, 라디에이터, 레인지, 냉장고와 같은 접지 표면에 몸이 닿지 않도록 하십시오.** 몸에 닿을 경우 감전될 위험이 높습니다.
- ▶ **전동공구를 비에 맞지 않게 하고 습기 있는 곳에 두지 마십시오.** 전동공구에 물이 들어가면 감전될 위험이 높습니다.
- ▶ **전원 코드를 잘못 사용하는 일이 없도록 하십시오.** 전원 코드를 잡고 전동공구를 운반해서는 안 되며, 콘센트에서 전원 플러그를 뽑을 때 전원 코드를 잡아 당겨서는 절대로 안 됩니다. 전원 코드가 열과 오일에 접촉하는 것을 피하고, 날카로운 모서리나 기기의 가동 부위에 닿지 않도록 주의 하십시오. 손상되거나 영긴 전원 코드는 감전을 유발할 수 있습니다.
- ▶ **실외에서 전동공구로 작업할 때는 실외용으로 적당할 연장 전원 코드만을 사용하십시오.** 실외용 연장 전원 코드를 사용하면 감전의 위험을 줄일 수 있습니다.
- ▶ **전동공구를 습기 찬 곳에서 사용해야 할 경우에는 누전 차단기를 사용하십시오.** 누전 차단기를 사용하면 감전 위험을 줄일 수 있습니다.

사용자 안전

- ▶ **신중하게 작업하며, 전동공구를 사용할 때 경솔하게 행동하지 마십시오.** 피로한 상태이거나 약물 복용 및 음주한 후에는 전동공구를 사용하지 마십시오. 전동공구를 사용할 때 잠시라도 주의가 산만해지면 중상을 입을 수 있습니다.
- ▶ **작업자 안전을 위한 장치를 사용하십시오.** 항상 보안경을 착용하십시오. 전동공구의 종류와 사용에 따라 먼지 보호 마스크, 미끄러지지 않는 안전화, 안전모 또는 귀마개 등의 안전한 복장을 하면 상해의 위험을 줄일 수 있습니다.
- ▶ **실수로 기기가 작동되지 않도록 주의하십시오.** 전동공구를 전원에 연결하거나 배터리를 끼우기 전에, 혹은 기기를 들거나 운반하기 전에, 전원 스위치가 꺼져 있는지 다시 확인하십시오. 전동공구를 운반할 때 전원 스위치가 손가락을 대거나 전원 스위치가 켜진 상태에서 전원을 연결하면 사고 위험이 높습니다.
- ▶ **전동공구를 사용하기 전에 조절하는 톨이나 키 등을 빼 놓으십시오.** 회전하는 부위에 있는 톨이나 키로 인해 상해를 입을 수 있습니다.
- ▶ **자신을 과신하지 마십시오.** 불안정한 자세를 피하고 항상 평형을 이룬 상태로 작업하십시오. 안정된 자세와 평형한 상태로 작업해야만이 의외의 상황에서도 전동공구를 안전하게 사용할 수 있습니다.

- ▶ **알맞은 작업복을 입으십시오.** 헐렁한 복장을 하거나 장신구를 착용하지 마십시오. 머리카락이 가동하는 기기 부위에 가까이 닿지 않도록 주의 하십시오. 헐렁한 복장, 장신구 혹은 긴 머리는 가동 부위에 말려 사고를 초래할 수 있습니다.
- ▶ **본진 추출장치나 수거장치의 조립이 가능한 경우, 이 장치가 연결되어 있는지, 제대로 작동이 되는지 확인하십시오.** 이러한 본진 추출장치를 사용하면 본진으로 인한 사고 위험을 줄일 수 있습니다.
- ▶ **툴을 자주 사용한다고 해서 안주하는 일이 없게 하고 공구의 안전 수칙을 무시하지 않도록 하십시오.** 부주의하게 취급하여 순간적으로 심각한 부상을 입을 수 있습니다.

전동공구의 올바른 사용과 취급

- ▶ **기기를 과부하 상태에서 사용하지 마십시오. 작업할 때 이에 적당한 전동공구를 사용하십시오.** 알맞은 전동공구를 사용하면 지정된 성능 한도 내에서 더 효율적으로 안전하게 작업할 수 있습니다.
- ▶ **전원 스위치가 고장 난 전동공구를 사용하지 마십시오.** 전원 스위치가 작동되지 않는 전동공구는 위험하므로, 반드시 수리를 해야 합니다.
- ▶ **전동공구를 조정하거나 액세서리 부품 교환 혹은 공구를 보관할 때, 항상 전원 콘센트에서 플러그를 미리 빼어 놓거나 배터리를 분리하십시오.** 이러한 조치는 실수로 전동공구가 작동하게 되는 것을 예방합니다.
- ▶ **사용하지 않는 전동공구는 어린이 손이 닿지 않는 곳에 보관하고, 전동공구 사용에 익숙지 않거나 이 사용 설명서를 읽지 않은 사람은 기기를 사용해서는 안 됩니다.** 경험이 없는 사람이 전동공구를 사용하면 위험합니다.
- ▶ **전동공구 및 액세서리를 조심스럽게 관리하십시오.** 가동 부위가 하자 없이 정상적인 기능을 하는지, 걸리는 부위가 있는지, 혹은 전동공구의 기능에 중요한 부품이 손상되지 않았는지 확인하십시오. 손상된 기기의 부품은 전동공구를 다시 사용하기 전에 반드시 수리를 맡기십시오. 제대로 관리하지 않은 전동공구의 경우 많은 사고를 유발합니다.
- ▶ **절단 공구를 날카롭고 깨끗하게 관리하십시오.** 날카로운 절단면이 있고 잘 관리된 절단공구는 걸리는 경우가 드물고 조절하기도 쉽습니다.
- ▶ **전동공구, 액세서리, 장착하는 공구 등을 사용할 때, 이 지시 사항과 특별한 기종 별로 나와있는 사용 방법을 준수하십시오.** 이때 작업 조건과 실시하려는 작업 내용을 고려하십시오. 원래 사용 분야가 아닌 다른 작업에 전동공구를 사용할 경우 위험한 상황을 초래할 수 있습니다.
- ▶ **손잡이 및 잡는 면을 건조하게 유지하고, 오일 및 그리스가 묻어 있지 않도록 깨끗하게 하십시오.** 손잡이 또는 잡는 면이 미끄러우면 예상치 못한 상황에서 안전한 취급 및 제어가 어려워집니다.

충전 전동공구의 올바른 사용과 취급

- ▶ **배터리를 충전할 때 제조 회사가 추천하는 충전 기만을 사용하여 재충전해야 합니다.** 특정 제품

의 배터리를 위하여 제조된 충전기에 적합하지 않은 다른 배터리를 충전할 경우 화재 위험이 있습니다.

- ▶ **각 전동공구용으로 나와있는 배터리만을 사용하십시오.** 다른 종류의 배터리를 사용하면 상해를 입거나 화재를 초래할 수 있습니다.
- ▶ **배터리를 사용하지 않을 때는, 각 극을 자극 할 수 있는 페이퍼 클립, 동전, 열쇠, 못, 나사 등 유사한 금속성 물체와 멀리하여 보관하십시오.** 배터리 극 사이에 쇼트가 일어나 화상을 입거나 화재를 야기할 수 있습니다.
- ▶ **배터리를 잘못 사용하면 누수가 생길 수 있습니다.** 누수가 생긴 배터리에 닿지 않도록 하십시오. 피부에 접촉하게 되었을 경우 즉시 물로 씻으십시오. 유체가 눈에 닿았을 경우 바로 의사와 상담하십시오. 배터리에서 나오는 유체는 피부에 자극을 주거나 화상을 입힐 수 있습니다.
- ▶ **손상된 배터리 또는 공구를 사용하지 마십시오.** 손상되었거나 개조된 배터리는 예기치 못한 특성으로 인해 화재, 폭발 또는 부상의 위험을 초래할 수 있습니다.
- ▶ **배터리 또는 공구가 화기 또는 지나치게 높은 온도에 노출되지 않도록 하십시오.** 화기 또는 130 °C 이상의 온도에 노출되면 폭발할 위험이 있습니다.
- ▶ **충전 지침을 준수하고 지침에 제시된 범위를 벗어난 온도에서 충전하지 마십시오.** 제시된 범위를 벗어난 부적절한 온도에서 충전할 경우 배터리가 손상되어 화재 발생의 위험이 증가됩니다.

서비스

- ▶ **전동공구 수리는 반드시 전문 인력에게 맡기고, 수리 정비 시 보쉬 순정 부품만을 사용하십시오.** 그렇게 함으로써 기기의 안전성을 오래 유지할 수 있습니다.
- ▶ **손상된 배터리는 절대 수리하지 마십시오.** 배터리 수리는 제조사 또는 공인 서비스센터에서만 진행할 수 있습니다.

스크류 드라이버 관련 안전 수칙

- ▶ **파스너가 숨겨진 배선에 접촉할 가능성이 있는 작업을 수행할 경우, 전동공구의 절연된 손잡이 면만 잡으십시오.** 파스너가 "전류가 흐르는" 전선에 접촉되면, 전동공구의 노출된 금속 부품에 "전류가 흐르는" 상태로 만들어 작업자가 감전될 수 있습니다.
- ▶ **보이지 않는 부위에 에너지 배선 및 배관 여부를 확인하려면 적당한 탐지기를 사용하거나 담당 전력 공급회사에 문의하십시오.** 전선에 접하게 되면 화재나 전기 충격을 야기할 수 있습니다. 가스관을 손상시키면 폭발 위험이 있습니다. 수도관을 파손하게 되면 재산 피해를 야기할 수 있습니다.
- ▶ **전동 공구를 잘 잡으십시오.** 스크류를 조이거나 풀 때 잠깐 동안 높은 반력 토크가 발생할 수 있습니다.

- ▶ **작업물을 잘 고정하십시오.** 고정장치나 기계 바이스에 끼워서 작업하면 손으로 잡는 것보다 더 안전합니다.
- ▶ **전동공구를 내려놓기 전에 기기가 완전히 멈추었는지 확인하십시오.** 삽입공구가 걸리거나 전동공구에 대한 통제가 어려워질 수 있습니다.
- ▶ **배터리가 손상되었거나 잘못 사용될 경우 증기가 발생할 수 있습니다.** 작업장을 환기시키고, 필요한 경우 의사와 상담하십시오. 증기로 인해 호흡기가 자극될 수 있습니다.
- ▶ **배터리를 분해하지 마십시오.** 단락이 발생할 위험이 있습니다.
- ▶ **못이나 스크류 드라이버 같은 뾰족한 물체 또는 외부에서 오는 충격 등으로 인해 축전지가 손상될 수 있습니다.** 내부 단락이 발생하여 배터리가 타거나 연기가 발생하고, 폭발 또는 과열될 수 있습니다.
- ▶ **제조사의 배터리 제품만 사용하십시오.** 그래야만 배터리 과부하의 위험을 방지할 수 있습니다.



배터리를 태양 광선 등 고열에 장시간 노출되지 않도록 하고 불과 물, 수분이 있는 곳에 두지 마십시오. 폭발 위험이 있습니다.

제품 및 성능 설명



모든 안전 수칙과 지침을 숙지하십시오. 다음의 안전 수칙과 지침을 준수하지 않으면 화재 위험이 있으며 감전 혹은 중상을 입을 수 있습니다.

사용 설명서 앞 부분에 제시된 그림을 확인하십시오.

규정에 따른 사용

본 전동공구는 각각 정해진 치수 범위 내에서 나사못을 끼우거나 푸는 작업 그리고 너트를 조이거나 푸는 작업을 하는 데 사용해야 합니다.

제품의 주요 명칭

제품의 주요 명칭에 표기되어 있는 번호는 기기 그림이 나와있는 면을 참고하십시오.

- (1) 톨 홀더
- (2) 회전방향 선택 스위치
- (3) 배터리 A)
- (4) 배터리 잠금 해제 버튼 A)
- (5) "PowerLight" 램프
- (6) 전원 스위치
- (7) 손잡이(절연된 손잡이 부위)
- (8) 장착 액세스리 (임팩트 소켓 등)

A) **도면이나 설명서에 나와있는 액세스리는 표준 공급부품에 속하지 않습니다.** 전체 액세스리는 저히 액세스리리 프로그램을 참고하십시오.

제품 사양

충전 임팩트 드라이버		GDS 18V-Li HT
제품 번호		3 601 JB1 3..
정격 전압	V=	18
무부하 속도	min ⁻¹	0-1900
타격률	min ⁻¹	0-2100
ISO 5393에 따른 경질 스크류 작업 시 최대 토크	Nm	650
작은 나사 직경	mm	M12-M20
툴 홀더		■ ½"
EPTA-Procedure 01:2014에 따른 중량	kg	2.7-3.2 ^{A)}
허용되는 주변 온도		
- 충전 시	°C	0...+45
- 작동 시 ^{B)} 및 보관 시	°C	-20...+50
권장 배터리		GBA 18V.. GBA 18V...W
권장하는 충전기		GAL 18...W ^{C)} GAL 18V.. GAX 18V-30 AL 1820 CV AL 1860 CV GAL 1880 CV GAL 3680 CV

- A) 사용하는 배터리에 따라 상이
B) 온도 <0 °C일 때 출력 제한
C) 유도식 배터리의 경우만 해당

조립

- ▶ 전동공구에 각종 작업(보수 정비 및 액세스리 교환 등)을 하거나 전동공구를 운반하거나 보관할 경우 배터리를 전동공구에서 빼십시오. 실수로 전원 스위치가 작동하게 되면 상해를 입을 위험이 있습니다.

배터리 충전하기

지침: 배터리는 일부 충전되어 공급됩니다. 배터리의 성능을 완전하게 보장하기 위해서는 처음 사용하기 전에 배터리를 충전기에 완전히 충전하십시오.

리튬이온 배터리는 항상 충전할 수 있으며, 이로 인해 수명이 단축되지 않습니다. 충전을 하중 중간에 중지해도 배터리가 손상되지 않습니다.

리튬 이온 배터리는 "전자 셀 보호(ECP)" 기능이 있어 과도하게 방전되지 않습니다. 배터리가 방전되면 안전 스위치가 작동하여 전동공구가 꺼지고 비트가 더 이상 움직이지 않습니다.

- ▶ 전동공구가 자동으로 작동이 중단된 경우 전원 스위치를 계속 누르지 마십시오. 배터리가 손상될 수 있습니다.

배터리 충전상태 표시기

배터리 충전상태 표시기에 있는 세 개의 녹색 LED는 배터리 (3)의 충전 상태를 나타냅니다. 안전상의 이유로 전동공구가 멈춰 있는 경우에만 잔량상태 확인이 가능합니다.

충전상태 표시기 버튼을 누르면, 충전 상태가 표시됩니다. 배터리 (3)가 분리된 상태에서도 표시 가능합니다.

LED	용량
연속등 3 x 녹색	≥ 2/3
연속등 2 x 녹색	≥ 1/3
연속등 1 x 녹색	< 1/3
점멸등 3 x 녹색	예비

충전상태 표시기 버튼을 눌렀는데도 LED가 켜지지 않으면 배터리가 손상된 것이므로 교환해 주어야 합니다.

배터리 분리하기

배터리 (3)는 배터리 해제 버튼 (4)이 실수로 눌러져 배터리가 빠지는 것을 방지하기 위해 잠금장치가 이중으로 되어 있습니다. 전동공구에 배터리가 끼워져 있는 동안 배터리는 스프링으로 제 위치에 고정됩니다.

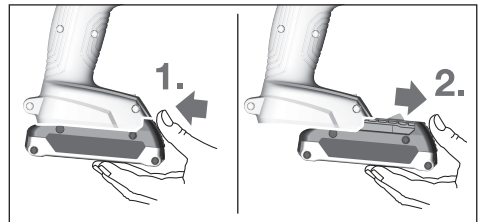

배터리 (3)를 분리하려면 배터리 해제 버튼 (4)을 누른 상태에서 배터리를 전동공구 앞쪽으로 당겨내십시오. 무리하게 힘을 가하지 마십시오.

공구 교환(그림 A 참조)

- ▶ 전동공구에 각종 작업(보수 정비 및 액세스리 교환 등)을 하거나 전동공구를 운반하거나 보관할 경우 배터리를 전동공구에서 빼십시오. 실수로 전원 스위치가 작동하게 되면 상해를 입을 위험이 있습니다.
- ▶ 전동공구의 통풍구를 주기적으로 청소하십시오. 모터의 팬은 하우징 내부로 먼지를 흡입하는데, 금속 가루가 너무 많이 쌓이면 전기 사고 위험을 초래할 수 있습니다.
- ▶ 삽입공구를 끼울 때 툴 홀더에 확실하게 끼워졌는지 확인하십시오. 삽입공구가 툴 홀더에 제대로 연결되어 있지 않으면 스크류 작업 시 빠질 수 있습니다.

삽입공구 (8)를 툴 홀더 (1)의 4각 모서리쪽으로 미십시오.

시스템에 따라 삽입공구 (8)는 툴 홀더 (1) 사이에 약간의 유격이 있을 수 있는데, 이는 기능/안전 상에 아무런 영향을 미치지 않습니다.

작동

작동 방법

비트가 끼워진 톨 홀더 (1) 는 기어와 충격 장치를 이용한 전기 모터에 의해 작동됩니다.

작업 과정은 **스크류 작업**과 **고정 작업**(충격 장치 작동)

두 단계로 나뉘어집니다.

충격 장치는 나사못과 연결이 되어 모터에 부하가 걸리게 되면 작동하기 시작합니다. 이때 충격 메커니즘은 모터의 힘을 균일한 회전 임팩트로 변환시킵니다. 나사못이나 너트를 풀 경우 이 과정이 반대로 진행됩니다.

기계 시동

배터리 장착하기

회전방향 선택 스위치 (2) 를 중앙에 위치시키면, 의도치 않게 전원이 켜지는 것을 방지할 수 있습니다.

배터리가 안전하게 고정될 때까지 충전한 배터리 (3) 를 앞쪽에서 전동공구의 다리쪽으로 미십시오.

회전방향 설정하기(그림 B 참조)

회전방향 선택 스위치 (2) 를 이용해 전동공구의 회전 방향을 변경할 수 있습니다. 전원 스위치 (6) 가 눌린 상태에서는 변경할 수 없습니다.

우회전: 볼트를 돌려 끼우고 너트를 조이려면 회전 방향 선택 스위치 (2) 를 좌측 끝까지 미십시오.

좌회전: 볼트 및 너트를 풀거나 돌려 빼려면 회전 방향 선택 스위치 (2) 를 우측 끝까지 미십시오.

전원 스위치 작동

전동공구를 **작동하려면** 전원 스위치 (6) 를 누르고 누른 상태를 유지하십시오.

전원 스위치 (6) 를 약간 또는 끝까지 누르면 램프 (5) 가 점등되기 때문에 조명 상태가 안 좋을 경우 작업 영역을 비출 수 있습니다.

전동공구의 **스위치를 끄려면** 전원 스위치 (6) 에서 손을 떼면 됩니다.

속도 조절

전원 스위치 (6) 를 밀어 이동시키는 만큼 전원이 켜진 전동공구의 회전속도를 조절할 수 있습니다.

전원 스위치 (6) 를 약간만 밀면 속도가 낮아집니다. 세게 누르면 속도가 빨라집니다.

사용방법

▶ **전동공구의 스위치가 꺼진 상태에서만 볼트/너트에 대십시오.** 회전하는 드릴 비트가 미끄러질 수 있습니다.

조임 토크는 임팩트 시간에 의해 좌우됩니다. 최대 로 달성 가능한 조임 토크는 임팩트에 의해 도달한 개별적인 토크의 합으로 이루어집니다. 6-10초 간의 임팩트 시간 후에 최대 토크에 달하게 됩니다. 이 시간이 지나면 조임 토크는 최소로 증가합니다.

임팩트 시간은 매번 필요한 조임 토크에 따라 계산해야 합니다. 실제 정해진 조임 토크는 항상 토크 렌치로 확인해야 합니다.

경질, 스프링 혹은 연질 시트의 스크류 작업

일련의 임팩트에 의해 나타난 토크를 측정하여 그래프로 표시하면 토크 커브 곡선이 생깁니다. 곡선의 높이는 달성할 수 있는 최대 토크이며, 경사 부위는 최대 토크에 달하는 시간을 나타냅니다.

토크의 기울기는 다음의 요소에 따라 달라집니다:

- 볼트/너트의 강도
- 받침대의 종류(와셔, 판 스프링, 실)
- 고정하려는 작업물의 강도
- 스크류 연결 부위의 윤활 상태

이에 따라 기기를 다음과 같이 사용할 수 있습니다:

- **경질 시트**는 와셔를 사용하여 금속과 금속에 스크류 체결하는 경우입니다. 이때 비교적 짧은 임팩트 시간 내에 최대 토크에 도달할 수 있습니다(급경사 특성 곡선). 불필요하게 장시간 작업하는 것은 기기에 손상을 줄 뿐입니다.
- **스프링 시트**는 금속과 금속에 스크류 체결하는 경우로, 스프링 와셔, 판 스프링, 원뿔형 스테드와 볼트/너트 혹은 연장 부품만 사용하는 경우입니다.
- **연질 시트**는 예를 들면 금속을 목재에 스크류 체결하는 경우나 혹은 납이나 섬유로 된 와셔를 기본 받침대로 사용하는 경우입니다.

스프링 시트나 연질 시트의 경우 최대 조임 토크는 경질 시트 경우 보다 낮습니다. 또한 임팩트 시간도 훨씬 오래 걸립니다.

DIN 267에 따른 강도 등급	일반 볼트				고강도 볼트			
	3.6	4.6	5.6	5.8	6.8	8.8	10.9	12.9
M12	22.6	30	37.6	50	60	80	113	135
M14	36	48	60	79	95	130	180	215
M16	55	73	92	122	147	196	275	330
M18	81	110	135	180	215	290	405	485
M20	115	155	190	255	305	410	580	690

참고

경질 작업 소재에 크고 긴 스크류를 끼우기 전에, 나사산의 중심 직경으로 스크류 길이의 약 2/3 에 해

당하는 깊이로 초기 드릴 작업을 하는 것이 좋습니다.

지침: 전동공구 안으로 아무런 금속성 부스러기가 들어가지 않도록 주의하십시오.

낮은 회전속도로 장시간 작업한 후에는 냉각을 위해 전동공구를 약 3분간 최대 회전속도로 공회전시키십시오.

배터리 취급 관련 지침

배터리에 습기 및 물이 들어가지 않게 하십시오. 배터리를 -20 °C 에서 50 °C 온도 범위에서만 보관 하십시오. 여름 같은 경우 배터리를 자동차 안에 두지 마십시오.

충전 후 작동 시간이 현저하게 짧아지면 배터리의 수명이 다한 것이므로 배터리를 교환해야 합니다. 폐기처리에 관련된 지시 사항을 준수하십시오.

보수 정비 및 서비스

보수 정비 및 유지

- ▶ 전동공구에 각종 작업(보수 정비 및 액세서리 교환 등)을 하거나 전동공구를 운반하거나 보관할 경우 배터리를 전동공구에서 빼십시오. 실수로 전원 스위치가 작동하게 되면 상해를 입을 위험이 있습니다.
- ▶ 안전하고 올바른 작동을 위하여 전동공구와 전동공구의 통풍구를 항상 깨끗이 하십시오.

AS 센터 및 사용 문의

AS 센터에서는 귀하 제품의 수리 및 보수정비, 그리고 부품에 관한 문의를 받고 있습니다. 대체 부품에 관한 분해 조립도 및 정보는 인터넷에서도 찾아볼 수 있습니다 - www.bosch-pt.com 보쉬 사용 문의 팀에서는 보쉬의 제품 및 해당 액세서리에 관한 질문에 기꺼이 답변 드릴 것입니다. 전문 작업자 및 개인 작업자를 위한 인터넷 포털 www.powertool-portal.de도 참조할 수 있습니다.

문의나 대체 부품 주문 시에는 반드시 제품 네임 플레이트에 있는 10자리의 부품번호를 알려 주십시오.

콜센터
080-955-0909

운반

포함되어 있는 리튬이온 배터리는 위험물 관련 규정을 따라야 합니다. 별도의 요구사항 없이 배터리를 사용자가 직접 도로 상에서 운반할 수 있습니다.

제3자를 통해 운반할 경우(항공 운송이나 운송 회사 등) 포장과 표기에 관한 특별한 요구 사항을 준수해야 합니다. 이 경우 발송 준비를 위해 위험물 전문가와 상담해야 합니다.

표면이 손상되지 않은 배터리만 사용하십시오. 배터리의 접촉 단자면을 덮어 붙인 상태로 내부에서 움직이지 않도록 배터리를 포장하십시오. 또한 이와 관련한 국내 규정을 준수하십시오.

처리



전동공구, 배터리, 액세서리 및 포장은 환경 친화적인 방법으로 재활용할 수 있도록 분류하십시오.



전동공구와 충전용 배터리/배터리를 가정용 쓰레기로 처리하지 마십시오!

오직 EU 국가에만 해당:

더이상 사용할 수 없는 전동공구 및 사용한 충전용 배터리/배터리는 유럽 가이드라인 2012/19/EU 및 유럽 가이드라인 2006/66/EC에 따라 분리 수거하여 환경 규정에 맞춰 재활용해야 합니다.

충전용 배터리/배터리:

리튬이온:

운반 단락에 나와 있는 지침을 참고하십시오. (참조 „운반“, 페이지 25).

ไทย

คำเตือนเพื่อความปลอดภัย

คำเตือนเพื่อความปลอดภัยทั่วไปสำหรับเครื่องมือไฟฟ้า

คำเตือน อ่านคำเตือนเพื่อความปลอดภัย คำแนะนำ ภาพประกอบ และข้อมูล

จำเพาะทั้งหมดที่จัดส่งมาพร้อมกับเครื่องมือไฟฟ้า

การไม่ปฏิบัติตามคำแนะนำทั้งหมดที่ระบุไว้ด้านล่างนี้อาจทำให้ถูกไฟฟ้าดูด เกิดไฟไหม้ และ/หรือได้รับบาดเจ็บอย่างร้ายแรง

เก็บรักษาคำเตือนและคำสั่งทั้งหมดสำหรับเปิดอ่านในภายหลัง

คำว่า "เครื่องมือไฟฟ้า" ในคำเตือนหมายถึง เครื่องมือไฟฟ้าของท่านที่ทำงานด้วยพลังงานไฟฟ้าจากแหล่งจ่ายไฟหลัก (มีสายไฟฟ้า) และเครื่องมือไฟฟ้าที่ทำงานด้วยพลังงานไฟฟ้าจากแบตเตอรี่ (ไร้สาย)

ความปลอดภัยในสถานที่ทำงาน

- ▶ **รักษาสถานที่ทำงานให้สะอาดและมีไฟส่องสว่างดี** สถานที่ที่มีมืดหรือกรุงังนำมาซึ่งอุบัติเหตุ
- ▶ **อย่าใช้เครื่องมือไฟฟ้าทำงานในสภาพบรรยากาศที่จุดติดไฟได้** เช่น ในที่มีมีของเหลวไวไฟ ก๊าซ หรือฝุ่น เมื่อใช้เครื่องมือไฟฟ้าจะเกิดประกายไฟซึ่งอาจจุดฝุ่นหรือไอให้ลุกเป็นไฟได้

- ▶ **ขณะใช้เครื่องมือไฟฟ้าทำงาน** ต้องกันเด็กและผู้ยืนดูให้ออกห่าง
การหันความสนใจอาจทำให้ท่านขาดการควบคุมเครื่องไว้

ความปลอดภัยเกี่ยวกับไฟฟ้า

- ▶ **ปลั๊กของเครื่องมือไฟฟ้าต้องเหมาะพอดีกับเต้าเสียบ** อย่าตัดแปลงปลั๊กไม่ว่าในลักษณะใดๆ อย่างเด็ดขาด อย่าใช้ปลั๊กฟ่วงต่อใดๆ กับเครื่องมือไฟฟ้าที่มีสายดิน ปลั๊กที่ไม่ตัดแปลงและเต้าเสียบที่เข้ากันช่วยลดความเสี่ยงจากการถูกไฟฟ้าดูด
- ▶ **หลีกเลี่ยงอย่าให้ร่างกายสัมผัสกับพื้นผิวที่ต่อสายดินหรือลงกราวด์ไว้** เช่น ท่อ เครื่องทำความร้อน เตา และตู้เย็น จะเสี่ยงอันตรายจากการถูกไฟฟ้าดูดมากขึ้นหากกระแสไฟฟ้าวิ่งผ่านร่างกายของท่านลงดิน
- ▶ **อย่าให้เครื่องมือไฟฟ้าถูกฝนหรืออยู่ในสภาพเปียกชื้น** หากน้ำเข้าไปในเครื่องมือไฟฟ้า จะเพิ่มความเสี่ยงจากการถูกไฟฟ้าดูด
- ▶ **อย่าใช้สายไฟฟ้าในทางที่ผิด** อย่าใช้สายไฟฟ้าเพื่อยก ding หรือถอดปลั๊กเครื่องมือไฟฟ้า กันสายไฟ้ออกห่างจากความร้อน น้ำมัน ขอบแหลมคม หรือชิ้นส่วนที่เคลื่อนที่ สายไฟฟ้าที่ชำรุดหรือพันกันยุ่งเพิ่มความเสี่ยงจากการถูกไฟฟ้าดูด
- ▶ **เมื่อใช้เครื่องมือไฟฟ้าทำงานกลางแจ้ง ให้ใช้สายไฟ** ต่อที่เหมาะสมสำหรับงานกลางแจ้ง การใช้สายไฟต่อที่เหมาะสมสำหรับงานกลางแจ้งช่วยลดอันตรายจากการถูกไฟฟ้าดูด
- ▶ **หากไม่สามารถหลีกเลี่ยงการใช้เครื่องมือไฟฟ้าทำงาน** ในสถานที่ที่เปียกชื้นได้ ให้ใช้สวิตช์ตัดวงจรเมื่อเกิดการรั่วไหลของไฟฟ้าจากสายดิน (RCD) การใช้สวิตช์ตัดวงจรเมื่อเกิดการรั่วไหลของไฟฟ้าจากสายดินช่วยลดความเสี่ยงต่อการถูกไฟฟ้าดูด

ความปลอดภัยของบุคคล

- ▶ **ท่านต้องอยู่ในสภาพเตรียมพร้อม รมีระดับวังในสิ่งที่** ท่านกำลังทำอยู่ และมีสติขณะใช้เครื่องมือไฟฟ้าทำงาน อย่าใช้เครื่องมือไฟฟ้าขณะที่ท่านกำลังเหนื่อย หรืออยู่ภายใต้การครอบงำของฤทธิ์ของยาเสพติด แอลกอฮอล์ และยา เมื่อใช้เครื่องมือไฟฟ้าทำงาน ในช่วงเวลาที่ท่านขาดความเอาใจใส่อาจทำให้บุคคลบาดเจ็บอย่างรุนแรงได้
- ▶ **ใช้อุปกรณ์ปกป้องร่างกาย** สวมแว่นตาป้องกันเสมอ อุปกรณ์ปกป้อง เช่น หน้ากากกันฝุ่น รองเท้ากันลื่น หมวกแข็ง หรือประภทกันเสียงดังที่ใช้ตามความเหมาะสมกับสภาพการทำงาน จะลดการบาดเจ็บทางร่างกาย

- ▶ **ป้องกันการติดเครื่องโดยไม่ตั้งใจ** ตรวจสอบให้แน่ใจว่าสวิตช์อยู่ในตำแหน่งปิดก่อนเชื่อมต่อเข้ากับแหล่งจ่ายไฟ และ/หรือแบตเตอรี่แพ็ค ยกหรือถือเครื่องมือถือเครื่องโดยใช้นิ้วหัวที่สวิตช์ หรือเสียบปลั๊กไฟฟ้าขณะสวิตช์เปิดอยู่ อาจนำไปสู่อุบัติเหตุที่ร้ายแรงได้
- ▶ **นำเครื่องมือปรับแต่งหรือประแจปากตายออกก่อนเปิด** สวิตช์เครื่องมือไฟฟ้า เครื่องมือหรือประแจปากตายที่วางอยู่กับส่วนของเครื่องที่กำลังหมุนจะทำให้บุคคลบาดเจ็บได้
- ▶ **อย่าเอื้อม โกลเกินไป** ตั้งทำยีนที่มั่นคงและวางน้ำหนักให้สมดุลตลอดเวลา ในลักษณะนี้ท่านสามารถควบคุมเครื่องมือไฟฟ้าในสถานการณ์ที่ไม่คาดคิดได้ดีกว่า
- ▶ **แต่งกายอย่างเหมาะสม** อย่าใส่เสื้อผ้าหลวมหรือสวมเครื่องประดับ เอาผมและเสื้อผ้าออกจากชิ้นส่วนที่เคลื่อนที่ เสื้อผ้าหลวม เครื่องประดับ และผมยาวอาจเข้าไปติดในชิ้นส่วนที่เคลื่อนที่
- ▶ **หากเครื่องมือไฟฟ้ามีข้อเชื่อมต่อกับเครื่องดูดฝุ่นหรือเครื่องเก็บผง** ให้ตรวจสอบให้แน่ใจว่าได้เชื่อมต่อและใช้งานอย่างถูกต้อง การใช้อุปกรณ์ดูดฝุ่นช่วยลดอันตรายที่เกิดจากฝุ่นได้
- ▶ **เมื่อใช้งานเครื่องมือขยครั้งจะเกิดความคุ้นเคย** อย่าให้ความคุ้นเคยทำให้ท่านเกิดความชะล่าใจและละเลยกฎเกณฑ์ด้านความปลอดภัยในการใช้งานเครื่อง การทำงานอย่างไม่ระมัดระวังอาจทำให้เกิดการบาดเจ็บอย่างร้ายแรงภายในเสี้ยววินาที

การใช้และการดูแลรักษาเครื่องมือไฟฟ้า

- ▶ **อย่างนึ่งกำลังเครื่องมือไฟฟ้า** ใช้เครื่องมือไฟฟ้าที่ถูกตั้งตรงตามลักษณะงานของท่าน เครื่องมือไฟฟ้าที่ถูกตั้งจะทำงานได้ดีกว่าและปลอดภัยกว่าในระดับสมรรถภาพที่ออกแบบไว้
- ▶ **อย่าใช้เครื่องมือไฟฟ้าถ้าสวิตช์ไม่สามารถเปิดปิดได้** เครื่องมือไฟฟ้าที่ไม่สามารถควบคุมการเปิดปิดด้วยสวิตช์ได้ เป็นเครื่องมือไฟฟ้าที่ไม่ปลอดภัยและต้องส่งซ่อมแซม
- ▶ **ก่อนปรับแต่งเครื่อง** เปลี่ยนอุปกรณ์ประกอบ หรือเก็บเครื่องเข้าที่ ต้องถอดปลั๊กออกจากแหล่งจ่ายไฟ และ/หรือถอดแบตเตอรี่แพ็คออกจากเครื่องมือไฟฟ้าหากถอดออกได้
มาตรการป้องกันเพื่อความปลอดภัยนี้ช่วยลดความเสี่ยงจากการติดเครื่องโดยไม่ตั้งใจ
- ▶ **เมื่อเลิกใช้งานเครื่องมือไฟฟ้า** ให้เก็บเครื่องไว้ในที่เด็กหยิบไม่ถึง และไมอนุญาตให้บุคคลที่ไม่คุ้นเคยกับเครื่องหรือบุคคลที่ไม่ได้อ่านคำแนะนำเหล่านี้ใช้เครื่องมือไฟฟ้าเป็นของอันตรายหากตกอยู่ในมือของผู้ใช้ที่ไม่ได้รับการฝึกฝน

- ▶ บำรุงรักษาเครื่องมือไฟฟ้าและอุปกรณ์ประกอบ ตรวจสอบชิ้นส่วนที่เคลื่อนที่ว่าวางไม่ตรงแนวหรือติดขัดหรือไม่ ตรวจสอบการแตกหักของชิ้นส่วนและสภาพอินไดท์ อาจมีผลต่อการทำงานของเครื่องมือไฟฟ้า หากชำรุดต้องส่งเครื่องมือไฟฟ้าไปซ่อมแซมก่อนใช้งาน อุบัติเหตุหลายอย่างเกิดขึ้นเนื่องจากดูแลรักษาเครื่องมือผิด
- ▶ รักษาเครื่องมือตัดให้คมและสะอาด หากบำรุงรักษาเครื่องมือที่มีขอบตัดแหลมคมอย่างถูกต้อง จะสามารถตัดได้ลื่นไม่ติดขัดและความคมใต้ง่ายกว่า
- ▶ ใช้เครื่องมือไฟฟ้า อุปกรณ์ประกอบ เครื่องมือ และอุปกรณ์อื่น ๆ ตรงตามคำแนะนำเหล่านี้ โดยคำนึงถึงเงื่อนไขการทำงานและงานที่จะทำ การใช้เครื่องมือไฟฟ้าทำงานที่ต่างไปจากวัตถุประสงค์การใช้งานของเครื่อง อาจนำไปสู่สถานการณ์ที่เป็นอันตรายได้
- ▶ ดูแลด้ามจับและพื้นผิวจับให้แห้ง สะอาด และปราศจากคราบไขมันและจาระบี ด้ามจับและพื้นผิวจับที่ลื่นทำให้หยิบจับได้ไม่ปลอดภัย และไม่สามารถควบคุมเครื่องมือในสถานการณ์ที่ไม่คาดคิด

การใช้และการดูแลรักษาเครื่องที่ใช้แบตเตอรี่

- ▶ ชาร์จไฟใหม่ด้วยเครื่องชาร์จที่บริษัทผู้ผลิตระบุไว้เท่านั้น เครื่องชาร์จที่เหมาะสมสำหรับชาร์จแบตเตอรี่แพคเกจหนึ่ง หากนำไปชาร์จแบตเตอรี่แพคเกจอื่น อาจเกิดไฟไหม้ได้
- ▶ ใช้เครื่องมือไฟฟ้าเฉพาะกับแบตเตอรี่แพคเกจที่กำหนดไว้เท่านั้น การใช้แบตเตอรี่แพคเกจอื่นเสี่ยงต่อการเกิดไฟไหม้หรือบาดเจ็บ
- ▶ เมื่อไม่ใช้งานแบตเตอรี่แพคเกจ ให้เก็บไว้ห่างวัตถุที่เป็นโลหะอื่นๆ เช่น คลิปหนีบกระดาษ เหรียญ กุญแจ ตะปู สกรู หรือวัตถุที่เป็นโลหะขนาดเล็กอื่นๆ ที่สามารถเชื่อมต่อขั้วหนึ่งไปยังอีกขั้วหนึ่งได้ การลัดวงจรของขั้วแบตเตอรี่อาจทำให้เกิดการไหม้หรือไฟลุกได้
- ▶ หากใช้แบตเตอรี่อย่างอาจมีของเหลวไหลออกมาจากแบตเตอรี่ได้ ให้หลีกเลี่ยงการสัมผัส หากสัมผัสโดยบังเอิญ ให้ใช้น้ำล้าง หากของเหลวไหลเข้าตา ให้ขอความช่วยเหลือจากแพทย์ด้วย ของเหลวที่ไหลออกมาจากแบตเตอรี่อาจทำให้เกิดอาการคันหรือแสบผิวหนังได้
- ▶ อย่าใช้แบตเตอรี่แพคเกจหรือเครื่องมือที่ชำรุดหรือดัดแปลง แบตเตอรี่ที่ชำรุดหรือดัดแปลงอาจแสดงอาการที่ไม่สามารถคาดเดาได้ ส่งผลให้เกิดไฟไหม้ ระเบิด หรือความเสี่ยงต่อการได้รับบาดเจ็บ

- ▶ อย่าให้แบตเตอรี่แพคเกจหรือเครื่องมือสัมผัสไฟหรืออุณหภูมิที่สูงเกินไป หากสัมผัสไฟหรืออุณหภูมิที่สูงกว่า 130 °C อาจทำให้เกิดการระเบิดได้
- ▶ ปฏิบัติตามคำแนะนำเกี่ยวกับการชาร์จทั้งหมด และตั้งไมชาร์จแบตเตอรี่แพคเกจหรือเครื่องมือ นอกช่วงอุณหภูมิที่กำหนดในคำแนะนำ การชาร์จแบตเตอรี่อย่างไม่ถูกวิธีหรือนอกช่วงอุณหภูมิที่กำหนด อาจทำให้แบตเตอรี่เสียหายและเพิ่มความเสี่ยงต่อการเกิดไฟไหม้

การบริการ

- ▶ ส่งเครื่องมือไฟฟ้าของท่านเข้ารับบริการจากช่างซ่อมที่มีคุณสมบัติเหมาะสม โดยใช้อะไหล่ที่เหมือนกันเท่านั้น ในลักษณะนี้ท่านจะแน่ใจได้ว่าเครื่องมือไฟฟ้าอยู่ในสภาพที่ปลอดภัย
- ▶ อย่าบำรุงรักษาแบตเตอรี่แพคเกจที่ชำรุดอย่างเด็ดขาด ต้องส่งไปบริษัทผู้ผลิตหรือศูนย์บริการที่ได้รับอนุญาตทำการบำรุงรักษาแบตเตอรี่แพคเกจเท่านั้น

คำเตือนเพื่อความปลอดภัยสำหรับไขควง

- ▶ เมื่อทำงานในบริเวณที่สกรูอาจสัมผัสสายไฟฟ้าที่ซ่อนอยู่ ต้องจับเครื่องมือไฟฟ้าตรงพื้นผิวจับที่หุ้มฉนวน หากสกรูสัมผัสสายที่ “มีกระแสไฟฟ้า” ไหลผ่าน จะทำให้ชิ้นส่วนโลหะที่ไม่ได้หุ้มฉนวนของเครื่องมือไฟฟ้าเกิด “มีกระแสไฟฟ้า” ด้วย และส่งผลให้ผู้ใช้งานเครื่องถูกไฟฟ้าดูดได้
- ▶ ใช้เครื่องตรวจจับที่เหมาะสมเพื่อตรวจหาสายไฟฟ้าหรือท่อสาธารณูปโภคที่อาจซ่อนอยู่ในบริเวณทำงานหรือติดตอมริษัทสาธารณูปโภคในพื้นที่เพื่อขอความช่วยเหลือ การสัมผัสกับสายไฟฟ้าอาจทำให้เกิดไฟไหม้หรือถูกไฟฟ้าดูด การทำให้ทองแท่งเสียหายอาจทำให้เกิดระเบิด การเจาะเข้าในท่อน้ำ ทำให้ทรัพย์สินเสียหาย
- ▶ จับเครื่องมือไฟฟ้าให้แน่น ขณะขันสกรูเข้าและคลายออก อาจเกิดแรงบิดสะท้อนช่วงสั้นๆ อาจรุนแรงได้
- ▶ ยึดชิ้นงานให้แน่น การยึดชิ้นงานด้วยเครื่องมือหนีบหรือแท่นจับจะมั่นคงกว่าการยึดด้วยมือ
- ▶ รอให้เครื่องมือไฟฟ้าหยุดสนิทก่อนวางเครื่องลงบนพื้น เครื่องมือที่ใส่อยู่อาจติดขัดและทำให้สูญเสียการควบคุมเครื่องมือไฟฟ้า
- ▶ เมื่อแบตเตอรี่ชำรุดและนำไปใช้งานอย่างไม่ถูกต้อง อาจมีไอระเหยออกมาได้ ให้สูดอากาศบริสุทธิ์ และหาแพทย์ในกรณีเจ็บปวด ไอระเหยอาจทำให้ระบมหายใจระคายเคือง
- ▶ อย่าเปิดแบตเตอรี่ อันตรายจากการลัดวงจร

- ▶ วัตถุที่แหลมคม ต. ย. เช่น ตะปูหรือไขควง หรือแรงกระทำภายนอก อาจทำให้แบตเตอรี่เสียหายได้ สิ่งเหล่านี้ อาจทำให้เกิดการลัดวงจรภายในและแบตเตอรี่ใหม่ มีควัน ระเบิด หรือร้อนเกินไป
- ▶ ไขแบตเตอรี่แพ็คเกจเฉพาะในผลิตภัณฑ์ของผู้ผลิตเท่านั้น ในลักษณะนี้ แบตเตอรี่แพ็คเกจจะได้รับการปกป้องจากการใช้งานเกินกำลังซึ่งเป็นอันตราย



ปกป้องแบตเตอรี่จากความร้อน รวมทั้ง ต. ย. เช่น จากการถูกแสงแดดส่องต่อเนื่อง จากไฟ น้ำ และความชื้น อันตรายจากการระเบิด



รายละเอียดผลิตภัณฑ์และข้อมูล

จำเพาะ



อ่านค่าเตือนเพื่อความปลอดภัยและคำแนะนำทั้งหมด การไม่ปฏิบัติตามคำเตือนและคำสั่งอาจเป็นสาเหตุให้ถูกไฟฟ้าดูด เกิดไฟไหม้ และ/หรือได้รับบาดเจ็บอย่างร้ายแรง

กรุณาดูภาพประกอบในส่วนหน้าของคู่มือการใช้งาน

ประโยชน์การใช้งานของเครื่อง

เครื่องมือไฟฟ้านี้ใช้สำหรับขันสกรูเข้าและคลายออก รวมทั้งขันน็อตให้แน่นและคลายออกในช่วงมิติที่กำหนดไว้

ส่วนประกอบที่แสดงภาพ

ลำดับเลขของส่วนประกอบผลิตภัณฑ์อ้างอิงถึงส่วนประกอบของเครื่องที่แสดงในหน้าภาพประกอบ

- (1) ด้ามจับเครื่องมือ
- (2) สวิตช์เปลี่ยนทิศทางการหมุน
- (3) แบตเตอรี่แพ็คเกจ^{A)}
- (4) แป้นปลดล็อกแบตเตอรี่แพ็คเกจ^{A)}
- (5) หลอดไฟ "Power Light"
- (6) สวิตช์เปิด-ปิด
- (7) ด้ามจับ (พื้นผิวจับหุ้มฉนวน)
- (8) เครื่องมือ (ต. ย. เช่น ลูกบ็อกซ์กระทง)

- A) อุปกรณ์ประกอบที่แสดงภาพหรืออธิบายไม่รวมอยู่ในการจัดส่งมาตรฐาน
กรุณาดูอุปกรณ์ประกอบทั้งหมดในรายการแสดงอุปกรณ์ประกอบของเรา

ข้อมูลทางเทคนิค

ไขควงกระแทกไร้สาย	GDS 18 V-Li HT	
หมายเลขสินค้า		3 601 JB1 3..
แรงดันไฟฟ้าฟักัด	V=	18
ความเร็วรอบเดินตัวเปล่า	รอบ/นาที่	0-1900
ความเร็วกระทง	รอบ/นาที่	0-2100
แรงบิดสูงสุด การขันสกรู รูปแบบแข็งตาม ISO 5393	นิวตันเมตร	650
Ø-น็อต	มม.	M12-M20
ด้ามจับเครื่องมือ		■ ½"
น้ำหนักตามระเบียบการ EPTA-Procedure 01:2014	กก.	2.7-3.2 ^{A)}
อุณหภูมิโดยรอบที่อนุญาต		
- เมื่อชาร์จ	°C	0... +45
- เมื่อใช้งาน ^{B)} และระหว่าง การเก็บรักษา	°C	-20... +50
แบตเตอรี่แพ็คเกจที่แนะนำ		GBA 18V.. GBA 18V...W
เครื่องชาร์จที่แนะนำ		GAL 18...W ^{C)} GAL 18V.. GAX 18V-30 AL 1820 CV AL 1860 CV GAL 1880 CV GAL 3680 CV

- A) ขึ้นอยู่กับแบตเตอรี่แพ็คเกจที่ใช้
B) สมรรถภาพจะน้อยลงที่อุณหภูมิต่ำ < 0 °C
C) สำหรับแบตเตอรี่แพ็คเกจแบบเหนียวเท่านั้น

การติดตั้ง

- ▶ ถอดแบตเตอรี่ออกจากเครื่องมือไฟฟ้าก่อนทำการปรับแต่งใดๆ ที่เครื่องมือไฟฟ้า (ต. ย. เช่น บำรุงรักษา เปลี่ยนเครื่องมือ ฯลฯ) รวมทั้งเมื่อขนย้ายและเก็บรักษา อันตรายจากการบาดเจ็บหากสวิตช์เปิด-ปิดติดขึ้นอย่างไม่ตั้งใจ

การชาร์จแบตเตอรี่

หมายเหตุ: แบตเตอรี่แพ็คที่จัดส่งมาถูกชาร์จมาแล้วบางส่วน เพื่อให้แบตเตอรี่แพ็คทำงานได้เต็มประสิทธิภาพ

ต้องชาร์จแบตเตอรี่แพ็ค

ในเครื่องชาร์จแบตเตอรี่ให้เต็มก่อนใช้งานเครื่องมือไฟฟ้าของท่านเป็นครั้งแรก

แบตเตอรี่ลิเธียม ไอออน

สามารถชาร์จได้ตลอดเวลาโดยอายุการใช้งานจะไม่ลดลง การชาร์จทิ้งไว้จะกระทบการชาร์จไม่ทำให้แบตเตอรี่แพ็คเสียหาย

“Electronic Cell Protection (ECP)” ช่วยป้องกันไม่ให้แบตเตอรี่ลิเธียม ไอออน จ่ายกระแสไฟออกอีก

เมื่อแบตเตอรี่แพ็คหมดไฟ วงจรป้องกันจะดับสวิทช์เครื่องเครื่องมือที่ใส่อยู่จะไม่หมุนต่อ

▶ **เมื่อเครื่องมือไฟฟ้าปิดสวิทช์ลงโดยอัตโนมัติ อย่างชัดเจน** หนึ่งเปิด-ปิด อีกต่อไป แบตเตอรี่แพ็คอาจชาร์จได้

ไฟแสดงสถานะการชาร์จแบตเตอรี่

ไฟ LED สีเขียวสามดวงของการแสดงสถานะการชาร์จแบตเตอรี่แสดงสถานะการชาร์จของแบตเตอรี่แพ็ค (3) ด้วยเหตุผลด้านความปลอดภัย ท่านสามารถตรวจสอบสถานะการชาร์จเฉพาะเมื่อเครื่องมือไฟฟ้าหยุดสนิทเท่านั้น

กดปุ่มสำหรับแสดงสถานะการชาร์จเพื่อแสดงสถานะการชาร์จ ท่านสามารถกดเมื่อได้ถอดแบตเตอรี่แพ็ค (3) ออกแล้ว

LED	ความจุ
ส่องสว่างต่อเนื่อง 3 x สีเขียว	$\geq 2/3$
ส่องสว่างต่อเนื่อง 2 x สีเขียว	$\geq 1/3$
ส่องสว่างต่อเนื่อง 1 x สีเขียว	$< 1/3$
ไฟกะพริบ 3 x สีเขียว	สำรอง

หลังจากกดปุ่มสำหรับแสดงสถานะการชาร์จแล้ว ไฟ LED ไม่ติดขึ้น แสดงว่าแบตเตอรี่แพ็คบกพร่องและต้องเปลี่ยนใหม่

การถอดแบตเตอรี่

แบตเตอรี่แพ็ค (3) มีกักรล็อกสองระดับเพื่อป้องกันไม่ให้แบตเตอรี่แพ็คร่วงหลุดออกมาหากกดแป้นปลดล็อกแบตเตอรี่แพ็ค (4) โดยไม่ตั้งใจ เมื่อแบตเตอรี่แพ็คถูกบรรจุอยู่ในเครื่องมือไฟฟ้า สปริงจะยึดแบตเตอรี่แพ็คให้เข้าตำแหน่ง

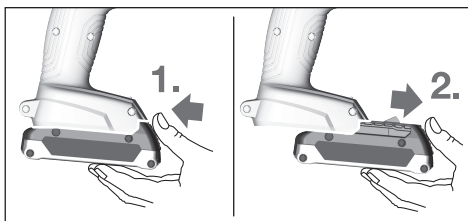

เมื่อต้องการถอดแบตเตอรี่แพ็ค (3) ออก ให้กดแป้นปลดล็อกแบตเตอรี่แพ็ค (4) และดึงแบตเตอรี่แพ็คไปข้างหน้าออกจากเครื่องมือไฟฟ้า **อย่าใช้กำลังดึง**

การเปลี่ยนเครื่องมือ (ดูภาพประกอบ A)

▶ **ถอดแบตเตอรี่ออกจากเครื่องมือไฟฟ้าก่อนทำการปรับแต่งใดๆ ที่เครื่องมือไฟฟ้า (ต. ย. เช่น บำรุงรักษา เปลี่ยนเครื่องมือ ฯลฯ) รวมทั้งเมื่อขนย้ายและเก็บรักษา** อันตรายจากการบาดเจ็บหากสวิทช์เปิด-ปิดติดขึ้นอย่างไม่ตั้งใจ

▶ **ทำความสะอาดของระบายนอากาศของเครื่องมือไฟฟ้าอย่างสม่ำเสมอ** พัดลมของมอเตอร์สามารถดูดฝุ่นเข้าไปภายในครอบเครื่อง และการสะสมที่มากเกินไปของโลหะผงอาจก่อให้เกิดอันตรายจากกระแสไฟฟ้า

▶ **เมื่อใส่เครื่องมือ ต้องตรวจสอบให้แน่ใจว่าเครื่องมือได้วางอยู่ในตำแหน่งจับเครื่องมืออย่างแน่นหนา** หากเครื่องมือไม่ถูกเชื่อมต่อกับตำแหน่งจับเครื่องมืออย่างแน่นหนา เครื่องมืออาจหลุดออกมาระหว่างการใช้งาน เลื่อนเครื่องมือ (8) เข้านทวิลิเธียมของตำแหน่งจับเครื่องมือ (1)

ตามการออกแบบ เครื่องมือ (8) จะมีระยะห่างบนตำแหน่งจับเครื่องมือ (1) เล็กน้อย ซึ่งจะไม่มีผลต่อการทำงาน/ความปลอดภัย

การปฏิบัติงาน

วิธีปฏิบัติงาน

ตำแหน่งจับเครื่องมือ (1) พร้อมเครื่องมือขับเคลื่อนด้วยมอเตอร์ไฟฟ้าผ่านเกียร์และกลไกกระแทก

ขั้นตอนการทำงานแบ่งออกเป็นสองระยะ:

การขนส่ง และ **การทำให้แน่น** (การทำงานกับกลไกกระแทก)

กลไกกระแทกจะถูกกระตุ้นในทันทีที่ขนส่งหรือติดตั้งในชิ้นงานแล้ว และด้วยเหตุนี้มอเตอร์จึงถูกโหลด ในขั้นตอนนี้กลไกกระแทกจะเปลี่ยนพลังงานมอเตอร์เป็นการกระแทกหมุนอย่างสม่ำเสมอ เมื่อคลายสกรูหรือนอตออก ให้ทำตามลำดับย้อนหลัง

การเริ่มต้นปฏิบัติงาน

การใส่แบตเตอรี่

ตั้งสวิทช์เปลี่ยนทิศทางการหมุน (2) ที่ตำแหน่งกลางเพื่อป้องกันไม่ให้เครื่องมือไฟฟ้าติดขึ้นโดยไม่ตั้งใจ

ดันแบตเตอรี่แพ็คที่ชาร์จแล้ว (3) เข้าในฐานของเครื่องมือไฟฟ้าจากทางด้านหน้าจนแบตเตอรี่แพ็คถูกล็อกอย่างแน่นหนา

การตั้งทิศทางการหมุน (รูปภาพประกอบ B)

ท่านสามารถเปลี่ยนทิศทางการหมุนของเครื่องมือไฟฟ้าได้ด้วยสวิตช์เปลี่ยนทิศทางการหมุน (2) อย่างไรก็ตาม หากสวิตช์เปิด-ปิด (6) ถูกกดอยู่ จะกลับทิศทางการหมุนไม่ได้

การหมุนทางขวา: สำหรับขันสกรูและขันน็อตให้แน่น ให้กดสวิตช์เปลี่ยนทิศทางการหมุน (2) ไปทางซ้ายจนสุด

การหมุนทางซ้าย: สำหรับคลายหรือหมุนสกรูและน็อตออก ให้กดสวิตช์เปลี่ยนทิศทางการหมุน (2) ไปทางขวาจนสุด

การเปิด-ปิดเครื่อง

สตาร์ท เครื่องมือไฟฟ้าโดยกดสวิตช์เปิด-ปิด (6) และกดค้างไว้

หลอดไฟ (5) ติดขึ้นเมื่อกดสวิตช์เปิด-ปิด (6) เล็กน้อยหรือเต็มที่ และช่วยส่องสว่างพื้นที่ทำงานเมื่อมีสภาพแสงที่ไม่เหมาะสม

ปิด เครื่องมือไฟฟ้าโดยปล่อยนิ้วจากสวิตช์เปิด-ปิด (6)

การปรับความเร็วรอบ

ท่านสามารถปรับความเร็วรอบของเครื่องมือไฟฟ้าที่เปิดสวิตช์อยู่ได้อย่างต่อเนื่องตามแรงกดมากขึ้นหรือน้อยลงสวิตช์เปิด-ปิด (6) การกดสวิตช์เปิด-ปิด (6) เมาจะให้ความเร็วรอบต่ำ การกดสวิตช์แรงยิ่งขึ้นจะให้ความเร็วรอบสูงขึ้น

ข้อแนะนำในการทำงาน

▶ **จับเครื่องมือไฟฟ้าเขามันหัวสกรู/น็อตเมื่อเครื่องปิดอยู่เท่านั้น** เครื่องมือที่หมุนอยู่อาจลื่นไหล

แรงบิดขึ้นอยู่กับระยะเวลากระแทก แรงบิดสูงสุดที่ได้เป็นผลจากยอดรวมของแต่ละแรงบิดที่ได้จากการกระแทก จะได้แรงบิดสูงสุดหลังจากกระแทกไปได้ 6-10 วินาที หลังช่วงเวลานี้ แรงบิดจะเพิ่มขึ้นเพียงเล็กน้อยเท่านั้น

ต้องกำหนดระยะเวลากระแทกสำหรับทุกๆ แรงบิดที่ต้องการตรวจสอบแรงบิดที่ได้จริงด้วยประแจวัดแรงบิดเสมอ

การขันสกรูแบบแข็ง แบบยึดหยุ่น หรือแบบนุ่ม

ในการทดสอบ แรงบิดที่ได้ในการกระแทกเป็นลำดับติดต่อกันจะถูกวัดและโอนเข้าแผนภาพ ซึ่งจะแสดงผลเป็นเส้นโค้งของลักษณะแรงบิด ระดับความสูงของเส้นโค้งคือแรงบิดสูงสุดที่ไปถึงได้ และระดับความชันแสดงระยะเวลาที่ไปถึงแรงบิดสูงสุด

ความลาดของแรงบิดขึ้นอยู่กับปัจจัยต่อไปนี้:

- คุณสมบัติความแข็งของสกรู/น็อต
- ชนิดของตัวเสริม (ประเภทวงแหวน สปริงแผ่น แผ่นซิล)
- คุณสมบัติความแข็งของวัสดุที่จะขันสกรู/โบลท์เข้าไป
- สภาพการหล่อลื่นน้ำมันตรงรอยต่อระหว่างสกรู/โบลท์และวัสดุที่ขันเข้าไป

เนื่องด้วยปัจจัยดังกล่าวข้างต้น จึงมีการขันแบบต่างๆ กันดังต่อไปนี้:

- **การขันแบบแข็ง** เกิดขึ้นเมื่อขันโลหะบนโลหะ โดยใช้ประเภทวงแหวน หลังใช้เวลากระแทกช่วงสั้นๆ ก็จะได้แรงบิดสูงสุด (เส้นโค้งมีลักษณะลาดชัน) การกระแทกเป็นเวลานานโดยไม่จำเป็นจะทำให้เครื่องชำรุดเสียหายเท่านั้น
- **การขันแบบยึดหยุ่น** เกิดขึ้นเมื่อขันโลหะบนโลหะ หากแต่ใช้วงแหวนสปริง สปริงแผ่น ตะปูหัวใหญ่หรือสกรู/น็อตที่มีกันรูปกรวย และเมื่อใช้ส่วนขยายเพิ่มเติม
- **การขันแบบนุ่ม** เกิดขึ้นเมื่อขันสกรู ต. ย. เช่น โลหะบนไม้หรือเมื่อใช้ประเภทวงแหวนตะกั่ว หรือประเภทวงแหวนโฟมอร์เป็นตัวเสริม

แรงบิดสูงสุดของการขันแบบยึดหยุ่นและแบบนุ่มจะต่ำกว่าแรงบิดขั้นแน่นอนสูงสุดของการขันแบบแข็ง และยังต้องการระยะเวลากระแทกที่ยาวนานกว่าอย่างเห็นได้ชัดอีกด้วย

เกรดความแข็งแรงตาม DIN 267	สกรู/โบลท์มาตรฐาน					โบลท์ความแข็งแรงสูง			
	3.6	4.6	5.6	5.8	6.8	8.8	10.9	12.9	
M12	22.6	30	37.6	50	60	80	113	135	
M14	36	48	60	79	95	130	180	215	
M16	55	73	92	122	147	196	275	330	
M18	81	110	135	180	215	290	405	485	
M20	115	155	190	255	305	410	580	690	

คำแนะนำ

ก่อนขันสกรูตัวใหญ่กว่า ยาวกว่า เข้าในเบร็วสัดแข็ง ท่านควรเจาะรูนำด้วยเส้นผ่าศูนย์กลางหลักของเกลียวลึกลงประมาณ 2/3 ของความยาวสกรู

หมายเหตุ: ตรวจสอบให้แน่ใจว่าไม่มีชิ้นส่วนโลหะขนาดเล็กใดๆ ลอดเข้าไปในเครื่องมือไฟฟ้า

หลังจากทำงานที่ความเร็วรอบต่ำเป็นเวลานาน ท่านควรเดินเครื่องมือไฟฟ้าด้วยเวลาที่ความเร็วสูงสุดเป็นเวลาประมาณ 3 นาทีเพื่อให้เครื่องเย็นลง

คำแนะนำสำหรับการจัดการที่เหมาะสมกับแบตเตอรี่แพ็ค

บ๊องกันแบตเตอรี่แพ็คจากความชื้นและน้ำ

เก็บรักษาแบตเตอรี่แพ็คในช่วงอุณหภูมิ - 20 °C ถึง 50 °C เท่านั้น อย่าปล่อยให้วางแบตเตอรี่แพ็คไว้ในรถยนต์ในช่วงฤดูร้อน

หลังจากชาร์จแบตเตอรี่แล้ว หากแบตเตอรี่แพ็คมีช่วงเวลาทำงานสั้นมาก แสดงว่าแบตเตอรี่แพ็คเสื่อมและต้องเปลี่ยนใหม่

อ่านและปฏิบัติตามข้อสังเกตสำหรับการกำจัดขยะ

การบำรุงรักษาและการบริการ

การบำรุงรักษาและการทำความสะอาด

▶ ถอดแบตเตอรี่ออกจากเครื่องมือไฟฟ้าก่อนทำการปรับแต่งใดๆ ที่เครื่องมือไฟฟ้า (ต. ย. เช่น บำรุงรักษา เปลี่ยนเครื่องมือ ฯลฯ) รวมทั้งเมื่อขนย้ายและเก็บรักษาอันตรายจากการบาดเจ็บหากสวิทช์เปิด-ปิดติดขึ้นอย่างไม่ตั้งใจ

▶ เพื่อให้ทำงานได้อย่างถูกต้องและปลอดภัย ตั้งรักษาเครื่องและช่องระบายอากาศให้สะอาดอยู่เสมอ

การบริการหลังการขายและการให้คำปรึกษาการใช้งาน

ศูนย์บริการหลังการขายของเรายินดีตอบคำถามของท่านที่เกี่ยวกับการบำรุงรักษาและการซ่อมแซมผลิตภัณฑ์รวมทั้งเรื่องอะไหล่ ภาพแยกชิ้นและข้อมูลเกี่ยวกับอะไหล่ยังสามารถดูได้ใน: www.bosch-pt.com

ทีมงานที่ปรึกษาของ บ๊อช ยินดีให้ข้อมูลเกี่ยวกับผลิตภัณฑ์ของเราและอุปกรณ์ประกอบต่างๆ

www.powertool-portal.de เว็บไซต์สำหรับช่างฝีมือและช่างสมัครเล่น

เมื่อต้องการสอบถามและสั่งซื้ออะไหล่ กรุณาแจ้งหมายเลขสินค้า 10 หลักบนแผ่นป้ายรุ่นของผลิตภัณฑ์ทุกครั้ง

ไทย

ไทย บริษัท โรเบิร์ต บ๊อช จำกัด

เอฟวายไอ เซ็นเตอร์ อาคาร 1 ชั้น 5

เลขที่ 2525 ถนนพระราม 4

แขวงคลองเตย เขตคลองเตย

กรุงเทพฯ 10110

โทร: +66 2012 8888

แฟกซ์: +66 2064 5800

www.bosch.co.th

ศูนย์บริการซ่อมและฝึกอบรม บ๊อช

อาคาร ลาซาลทาวเวอร์ ชั้น G ห้องเลขที่ 2

บ้านเลขที่ 10/11 หมู่ 16

ถนนศรีนครินทร์

ตำบลบางแก้ว อำเภอบางพลี

จังหวัดสมุทรปราการ 10540

ประเทศไทย

โทรศัพท์ 02 7587555

โทรสาร 02 7587525

การขนส่ง

แบตเตอรี่ลิเธียม ไอออน ที่บรรจุอยู่ภายใต้ข้อกำหนดแห่งกฎหมายสินค้าอันตราย วัสดุสามารถขนส่งแบตเตอรี่แพ็คโดยทางถนนโดยไม่มีข้อบังคับอื่นหากขนส่งโดยบุคคลที่สาม (เช่น : การขนส่งทางอากาศ หรือตัวแทนขนส่งสินค้า) ต้องปฏิบัติตามข้อกำหนดพิเศษเกี่ยวกับการบรรจุภัณฑ์และการติดฉลาก สำหรับการจัดเตรียมสิ่งของที่จะจัดส่งจำเป็นต้องปรึกษามูลนิธิช่วยเหลือด้านวัตถุอันตราย แบตเตอรี่แพ็คเมื่อตัวหุ้มไม่ชำรุดเสียหายเท่านั้น ให้นำแบตเตอรี่แพ็ค กาวพันปิดหน้าลิ้มส์ที่เปิดอยู่ และนำแบตเตอรี่แพ็คใส่กล่องบรรจุโดยไม่ให้เคลื่อนไปมาในกล่องได้ นอกจากนี้ กรุณาปฏิบัติตามกฎระเบียบของประเทศซึ่งอาจมีรายละเอียดเพิ่มเติม

การกำจัดขยะ



เครื่องมือไฟฟ้า แบตเตอรี่แพ็ค อุปกรณ์ประกอบ และหีบห่อ ต้องนำ

ไปแยกประเภทวัสดุเพื่อนำกลับมาใช้ใหม่โดยไม่ทำลายสภาพแวดล้อม



อย่าทิ้งเครื่องมือไฟฟ้าและแบตเตอรี่แพ็ค/แบตเตอรี่ที่นำกลับมาชาร์จใหม่ได้ ลงในขยะบ้าน!

สำหรับประเทศสมาชิกสหภาพยุโรปเท่านั้น:

ตามระเบียบสหภาพยุโรป 2012/19/EU ต้องนำเครื่องมือไฟฟ้าที่ไม่สามารถใช้งานได้อีกต่อไป และตามระเบียบสหภาพยุโรป 2006/66/EC ต้องนำแบตเตอรี่แพ็ค/แบตเตอรี่ที่ชำรุดหรือใช้แล้วไปเก็บแยกต่างหากและส่งเข้าสู่กระบวนการรีไซเคิลที่เป็นมิตรต่อสิ่งแวดล้อม

แบตเตอรี่แพ็ค/แบตเตอรี่:

ลิเธียม ไอออน:

กรุณายกยัดตามคำแนะนำในบทความนี้ (ดู "การขนย้าย", หน้า 31)

Bahasa Indonesia

Petunjuk Keselamatan

Petunjuk keselamatan umum untuk perkakas listrik

⚠ PERINGATAN Baca semua peringatan, petunjuk, ilustrasi, dan spesifikasi keselamatan yang diberikan bersama perkakas listrik ini. Kesalahan dalam menjalankan petunjuk di bawah ini dapat mengakibatkan sengatan listrik, kebakaran, dan/atau cedera serius.

Simpanlah semua peringatan dan petunjuk untuk penggunaan di masa mendatang.

Istilah "perkakas listrik" dalam peringatan mengacu pada perkakas listrik yang dioperasikan dengan listrik (mengggunakan kabel) atau perkakas listrik yang dioperasikan dengan baterai (tanpa kabel).

Keamanan tempat kerja

- ▶ **Jaga kebersihan dan pencahayaan area kerja.** Area yang berantakan atau gelap dapat memicu kecelakaan.
- ▶ **Jangan mengoperasikan perkakas listrik di lingkungan yang dapat memicu ledakan, seperti adanya cairan, gas, atau debu yang mudah terbakar.** Perkakas listrik dapat memancarkan bunga api yang kemudian mengakibatkan debu atau uap terbakar.
- ▶ **Jauhkan dari jangkauan anak-anak dan pengamat saat mengoperasikan perkakas listrik.** Gangguan dapat menyebabkan hilangnya kendali.

Keamanan listrik

- ▶ **Steker perkakas listrik harus sesuai dengan stopkontak. Jangan pernah memodifikasi steker. Jangan menggunakan steker adaptor bersama dengan perkakas listrik yang terhubung dengan sistem grounding.** Steker yang tidak dimodifikasi dan stopkontak yang cocok akan mengurangi risiko sengatan listrik.
- ▶ **Hindari kontak badan dengan permukaan yang terhubung dengan sistem grounding, seperti pipa, radiator, kompor, dan lemari es.** Terdapat peningkatan risiko terjadinya sengatan listrik jika badan Anda terhubung dengan sistem grounding.
- ▶ **Perkakas listrik tidak boleh terpapar hujan atau basah.** Air yang masuk ke dalam perkakas listrik menambah risiko terjadinya sengatan listrik.

- ▶ **Jangan menyalahgunakan kabel. Jangan gunakan kabel untuk membawa, menarik, atau melepas steker perkakas listrik. Jauhkan kabel dari panas, minyak, tepi yang tajam, atau komponen yang bergerak.** Kabel listrik yang rusak atau tersangkut menambah risiko terjadinya sengatan listrik.
- ▶ **Saat mengoperasikan perkakas listrik di luar ruangan, gunakan kabel ekstensi yang sesuai untuk penggunaan di luar ruangan.** Penggunaan kabel yang cocok untuk pemakaian di luar ruangan mengurangi risiko terjadinya sengatan listrik.
- ▶ **Jika perkakas listrik memang harus dioperasikan di tempat yang lembap, gunakan pemutus arus listrik residu (RCD).** Penggunaan RCD akan mengurangi risiko terjadinya sengatan listrik.

Keselamatan personel

- ▶ **Tetap waspada, perhatikan aktivitas yang sedang dikerjakan dan gunakan akal sehat saat mengoperasikan perkakas listrik. Jangan gunakan perkakas listrik saat mengalami kelelahan atau di bawah pengaruh narkoba, alkohol, atau obat-obatan.** Jika perkakas listrik dioperasikan dengan daya konsentrasi yang rendah, hal tersebut dapat menyebabkan cedera serius.
- ▶ **Gunakan peralatan pelindung diri. Selalu kenakan pelindung mata.** Penggunaan perlengkapan pelindung seperti penutup telinga, helm, sepatu anti licin, dan masker debu akan mengurangi cedera.
- ▶ **Hindari start yang tidak disengaja. Pastikan switch berada di posisi off sebelum perkakas listrik dihubungkan ke sumber daya listrik dan/atau baterai, diangkat, atau dibawa.** Membawa perkakas listrik dengan jari menempel pada tombol atau perkakas listrik dalam keadaan hidup dapat memicu kecelakaan.
- ▶ **Singkirkan kunci penyetel atau kunci pas sebelum menghidupkan perkakas listrik.** Perkakas atau kunci pas yang masih menempel pada komponen perkakas listrik yang berputar dapat menyebabkan cedera.
- ▶ **Jangan melampaui batas. Berdirilah secara mantap dan selalu jaga keseimbangan.** Hal ini akan memberikan kontrol yang lebih baik terhadap perkakas listrik pada situasi yang tak terduga.
- ▶ **Kenakan pakaian dengan wajar. Jangan mengenakan perhiasan atau pakaian yang longgar. Jauhkan rambut dan pakaian dari komponen yang bergerak.** Pakaian yang longgar, rambut panjang, atau perhiasan dapat tersangkut dalam komponen yang bergerak.
- ▶ **Jika disediakan perangkat untuk sambungan pengisapan debu dan alat pengumpulan, pastikan perangkat tersebut terhubung dan digunakan dengan benar.** Penggunaan alat pengumpulan dapat mengurangi bahaya yang disebabkan oleh debu.
- ▶ **Jangan berpuas diri dan mengabaikan prinsip keselamatan karena terbiasa mengoperasikan perkakas.** Tindakan yang kurang hati-hati dapat

mengakibatkan cedera serius dalam waktu sepersekian detik.

Penggunaan dan pemeliharaan perkakas listrik

- ▶ **Jangan memaksakan perkakas listrik. Gunakan perkakas listrik yang sesuai untuk pekerjaan yang dilakukan.** Perkakas listrik yang sesuai akan bekerja dengan lebih baik dan aman sesuai tujuan penggunaan.
- ▶ **Jangan gunakan perkakas listrik dengan switch yang tidak dapat dioperasikan.** Perkakas listrik yang switchnya yang tidak berfungsi dapat menimbulkan bahaya dan harus diperbaiki.
- ▶ **Lepaskan steker dari sumber listrik dan/atau lepas baterai, jika dapat dilepaskan dari perkakas listrik sebelum menyetel, mengganti aksesoris, atau menyimpan perkakas listrik.** Tindakan preventif akan mengurangi risiko menghidupkan perkakas listrik secara tidak disengaja.
- ▶ **Jauhkan dan simpan perkakas listrik dari jangkauan anak-anak dan jangan biarkan orang-orang yang tidak mengetahui cara menggunakan perkakas listrik, mengoperasikan perkakas listrik.** Perkakas listrik dapat membahayakan jika digunakan oleh orang-orang yang tidak terlatih.
- ▶ **Lakukan pemeliharaan perkakas listrik dan aksesoris. Periksa komponen yang bergerak apabila tidak lurus atau terikat, kerusakan komponen, dan kondisi lain yang dapat mengganggu pengoperasian perkakas listrik. Apabila rusak, perbaiki perkakas listrik sebelum digunakan.** Kecelakaan sering terjadi karena perkakas listrik tidak dirawat dengan baik.
- ▶ **Jaga ketajaman dan kebersihan alat.** Alat pemotong dengan pisau pemotong yang tajam dan dirawat dengan baik tidak akan mudah tersangkut dan lebih mudah dikendalikan.
- ▶ **Gunakan perkakas listrik, aksesoris, dan komponen perkakas dll sesuai dengan petunjuk ini, dengan mempertimbangkan kondisi kerja dan pekerjaan yang akan dilakukan.** Penggunaan perkakas listrik untuk tujuan berbeda dari fungsinya dapat menyebabkan situasi yang berbahaya.
- ▶ **Jaga gagang dan permukaan genggam agar tetap kering, bersih, dan bebas dari minyak dan lemak.** Gagang dan permukaan genggam yang licin tidak menjamin keamanan kerja dan kontrol alat yang baik pada situasi yang tidak terduga.

Penggunaan dan pemeliharaan perkakas baterai

- ▶ **Isi ulang daya hanya dengan pengisi daya yang ditentukan oleh produsen.** Pengisi daya yang sesuai untuk satu jenis set baterai dapat menyebabkan risiko kebakaran apabila digunakan dengan set baterai lain.
- ▶ **Hanya gunakan perkakas listrik dengan set baterai yang dirancang khusus.** Penggunaan set baterai lain dapat menyebabkan risiko cedera dan kebakaran.
- ▶ **Apabila set baterai tidak digunakan, jauhkan dari benda logam lainnya, seperti klip kertas, koin, kunci, paku, sekrup, atau benda logam kecil lainnya yang**

dapat membuat sambungan dari satu terminal ke terminal lainnya. Memendekkan terminal baterai dapat menyebabkan kebakaran atau api.

- ▶ **Cairan dapat keluar dari baterai jika baterai tidak digunakan dengan benar; hindari kontak. Jika terjadi kontak secara tidak disengaja, bilas dengan air. Jika cairan mengenai mata, segera hubungi bantuan medis.** Cairan yang keluar dari baterai dapat menyebabkan iritasi atau luka bakar.
- ▶ **Jangan gunakan set baterai atau perkakas yang rusak atau telah dimodifikasi.** Baterai yang rusak atau telah dimodifikasi dapat menimbulkan kejadian yang tak terduga seperti kebakaran, ledakan, atau risiko cedera.
- ▶ **Jangan meletakkan set baterai atau perkakas di dekat api atau suhu tinggi.** Paparan terhadap api atau suhu di atas 130 °C dapat memicu ledakan.
- ▶ **Ikuti semua petunjuk pengisian daya dan jangan mengisi daya set baterai atau perkakas di luar rentang suhu yang ditentukan dalam petunjuk.** Pengisian daya yang tidak tepat atau di luar rentang suhu yang ditentukan dapat merusak baterai dan meningkatkan risiko kebakaran.

Servis

- ▶ **Minta teknisi berkualifikasi untuk menyervis perkakas listrik dengan hanya menggunakan suku cadang yang identik.** Dengan demikian, hal ini akan memastikan keamanan perkakas listrik.
- ▶ **Jangan pernah melakukan servis pada baterai yang telah rusak.** Servis baterai hanya boleh dilakukan oleh produsen atau penyedia servis resmi.

Petunjuk Keselamatan untuk Obeng

- ▶ **Pegang perkakas listrik pada permukaan gagang isolator saat pengoperasian yang memungkinkan alat pengencang bersentuhan dengan kabel yang tidak terlihat.** Menyentuh alat pengencang yang dialiri listrik dapat menyebabkan bagian logam perkakas listrik dialiri listrik, sehingga berisiko mengakibatkan sengatan listrik pada operator.
- ▶ **Gunakanlah alat detektor logam yang cocok untuk mencari kabel dan pipa yang tidak terlihat atau hubungi perusahaan pengadaan setempat.** Sentuhan dengan kabel-kabel listrik dapat mengakibatkan api dan kontak listrik. Pipa gas yang rusak dapat mengakibatkan ledakan. Pipa air yang rusak mengakibatkan barang-barang menjadi rusak.
- ▶ **Pegang perkakas listrik dengan kencang.** Saat mengencangkan dan mendorong obeng dapat terjadi reaksi torsi yang tinggi sesaat.
- ▶ **Gunakan alat kerja dengan aman.** Benda yang ditahan dalam alat pemegang atau baus lebih aman daripada benda yang dipegang dengan tangan.
- ▶ **Sebelum meletakkan perkakas listrik, tunggulah hingga perkakas berhenti berputar.** Alat kerja dapat tersangkut dan menyebabkan perkakas listrik tidak dapat dikendalikan.

- ▶ **Asap dapat keluar apabila terjadi kerusakan atau penggunaan yang tidak tepat pada baterai.** Biarkan udara segar mengalir masuk dan jika Anda merasa tidak enak badan, pergilah ke dokter. Uap tersebut bisa mengganggu saluran pernafasan.
- ▶ **Jangan membuka baterai.** Ada bahaya terjadinya korsleting.
- ▶ **Baterai dapat rusak akibat benda-benda lancip, seperti jarum, obeng, atau tekanan keras dari luar.** Hal ini dapat menyebabkan terjadinya hubungan singkat internal dan baterai dapat terbakar, berasap, meledak, atau mengalami panas berlebih.
- ▶ **Hanya gunakan baterai pada produk yang dibuat oleh produsen.** Hanya dengan cara ini, baterai dapat terlindungi dari kelebihan muatan.



Lindungi baterai dari panas, misalnya terpapar sinar matahari dalam waktu yang lama, api, air, dan kelembapan. Terdapat bahaya ledakan.



Spesifikasi produk dan performa



Bacalah semua petunjuk keselamatan dan petunjuk penggunaan. Kesalahan dalam menjalankan petunjuk keselamatan dan petunjuk penggunaan dapat mengakibatkan kontak listrik, kebakaran, dan/atau luka-luka

yang berat.

Perhatikan ilustrasi yang terdapat pada sisi sampul panduan pengoperasian.

Tujuan penggunaan

Perkakas listrik ini cocok untuk memasang dan mengendurkan sekrup serta untuk mengencangkan dan mengendurkan mur masing-masing dalam batas ukuran yang ditentukan.

Ilustrasi komponen

Nomor-nomor dari bagian-bagian perkakas pada gambar sesuai dengan gambar perkakas listrik pada halaman bergambar.

- (1) Dudukan alat kerja
- (2) Switch arah putaran
- (3) Baterai ^{A)}
- (4) Tombol pembuka kunci baterai ^{A)}
- (5) Lampu "PowerLight"
- (6) Tombol on/off
- (7) Gagang (genggaman isolator)
- (8) Alat kerja (mis. kunci sok)

A) Aksesori yang ada pada gambar atau yang dijelaskan tidak termasuk dalam lingkup pengiriman standar. Semua aksesori yang ada dapat Anda lihat dalam program aksesori kami.

Data teknis

Impact driver berdaya baterai	GDS 18 V-Li HT	
Nomor seri		3 601 JB1 3..
Tegangan nominal	V=	18
Kecepatan idle	min ⁻¹	0–1 900
Jumlah getaran	min ⁻¹	0–2 100
Torsi maks. penyekrupan ketat menurut ISO 5393	Nm	650
Ø (diameter) sekrup mesin	mm	M12–M20
Dudukan alat kerja		■ ½"
Berat sesuai dengan EPTA-Procedure 01:2014	kg	2,7–3,2 ^{A)}
Suhu sekitar yang diizinkan		
– saat melakukan pengisian daya	°C	0... +45
– saat pengoperasian ^{B)} dan saat disimpan	°C	-20... +50
Baterai yang disarankan		GBA 18V.. GBA 18V...W
Pengisi daya baterai yang direkomendasikan		GAL 18...W ^{O)} GAL 18V.. GAX 18V-30 AL 1820 CV AL 1860 CV GAL 1880 CV GAL 3680 CV

A) tergantung pada baterai yang digunakan

B) daya terbatas pada suhu <0 °C

C) hanya untuk baterai induktif

Cara memasang

- ▶ **Sebelum melakukan semua pekerjaan pada perkakas listrik (misalnya merawat, mengganti alat kerja, dsb.) serta selama transpor dan penyimpanan, keluarkanlah baterai dari perkakas listrik.** Terdapat risiko cedera apabila tombol untuk menghidupkan dan mematikan dioperasikan tanpa sengaja.

Cara mengisi baterai

Catatan: Baterai dikirim dalam keadaan terisi sebagian. Untuk memastikan kinerja penuh baterai, isi penuh daya baterai ke pengisi daya sebelum menggunakannya untuk pertama kali.

Daya baterai li-ion dapat diisi setiap saat tanpa mengurangi masa pakainya. Penghentian proses pengisian daya tidak merusak baterai.

Baterai li-ion terlindungi dari pengosongan daya total dengan "Electronic Cell Protection (ECP)". Jika baterai habis, perkakas listrik dimatikan oleh pengaman: Alat sisipan berhenti beroperasi.

- ▶ **Jangan menekan kembali tombol on/off jika perkakas listrik mati secara otomatis.** Baterai dapat rusak.

Indikator level pengisian baterai

Ketiga LED berwarna hijau pada indikator level pengisian baterai menunjukkan level pengisian baterai (3). Demi keselamatan kerja, keadaan keberisian baterai hanya bisa diperiksa selama perkakas listrik dalam keadaan berhenti. Tekan tombol tampilan level pengisian baterai untuk menampilkan status daya baterai. Hal ini dimungkinkan saat baterai dikeluarkan (3).

LED	Kapasitas
Lampu permanen 3 x hijau	≥2/3
Lampu permanen 2 x hijau	≥1/3
Lampu permanen 1 x hijau	< 1/3
Menyala berkedip hijau 3 x	Cadangan

Apabila LED tidak menyala setelah menekan tombol tampilan level pengisian baterai, maka baterai tersebut rusak dan harus diganti.

Melepas baterai

Baterai (3) memiliki dua sistem pengunci untuk mencegah baterai jatuh jika tombol pelepas baterai (4) ditekan secara tidak sengaja. Selama baterai berada di dalam perkakas listrik, baterai ditahan dalamudukannya dengan pegas.

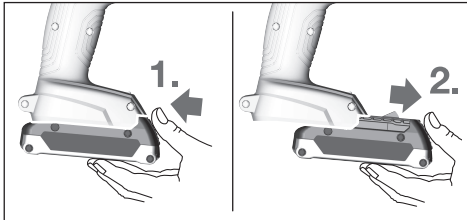

Untuk melepas baterai (3), tekan tombol pelepas (4) dan tarik baterai ke depan dari perkakas listrik. **Jangan melepas baterai dengan paksa.**

Mengganti alat sisipan (lihat gambar A)

- ▶ **Sebelum melakukan semua pekerjaan pada perkakas listrik (misalnya merawat, mengganti alat kerja, dsb.) serta selama transpor dan penyimpanan, keluarkanlah baterai dari perkakas listrik.** Terdapat risiko cedera apabila tombol untuk menghidupkan dan mematikan dioperasikan tanpa sengaja.
- ▶ **Bersihkan ventilasi udara pada perkakas listrik secara berkala.** Kipas motor dapat menyerap debu ke dalam housing dan kumpulan serbuk logam yang terlalu banyak dapat menyebabkan bahaya listrik.
- ▶ **Pastikan bahwa alat terpasang padaudukan alat kerja saat memasang alat sisipan.** Jika alat kerja tidak dipegang secara aman oleh pemegang alat kerja, alat kerja dapat terlepas selama penyekrupan.

Pasang alat kerja (8) pada kotakudukan alat kerja (1).

Karena sistem, alat sisipan terletak (8) padaudukan alat kerja dengan beberapa peralatan (1); hal ini tidak mempengaruhi fungsi/keamanan.

Penggunaan

Cara kerja

Dudukan alat (1) dengan alat sisipan digerakkan dengan motor listrik melalui transmisi dan alat penggetar. Proses pengerjaan terbagi ke dalam dua tahap: **menyekrup** dan **mengcangkang** (alat penggetar beroperasi).

Alat penggetar mulai beraksi begitu sekrup mulai terkunci dan motor dibebani. Dengan demikian alat penggetar mengubah daya motor menjadi getaran putar yang berkekuatan sama. Saat melepas sekrup atau mur, proses berlangsung dengan urutan sebaliknya.

Cara penggunaan

Memasang baterai

Setel switch arah putaran (2) pada posisi tengah untuk melindungi perkakas listrik sebelum dinyalakan secara tidak sengaja.

Pasang baterai yang telah diisi (3) ke dalam kaki perkakas listrik dari depan hingga baterai terkunci dengan aman.

Mengatur arah putaran (lihat gambar B)

Arah putaran perkakas listrik dapat diubah dengan switch pengubah arah (2). Hal tersebut tidak dapat dilakukan jika tombol on/off (6) ditekan.

Searah jarum jam: Untuk memasang sekrup dan mur, tekan switch pengubah arah (2) ke kiri hingga maksimal.

Berlawanan arah jarum jam: Untuk mengendurkan atau melepas sekrup dan mur, tekan switch pengubah arah (2) ke kanan hingga maksimal.

Mengaktifkan/menonaktifkan perkakas listrik

Untuk **menggunakan pertama kali** perkakas listrik, tekan dan tahan tombol on/off (6).

Lampu (5) akan menyala saat tombol on/off (6) ditekan singkat atau ditekan kuat dan dapat membantu menerangi area kerja saat kondisi cahaya minim.

Untuk **menonaktifkan** perkakas listrik, lepaskan tombol on/off (6).

Menyetel kecepatan

Kecepatan perkakas listrik yang diaktifkan dapat disetel terus-menerus tergantung seberapa kuat tombol on/off (6) ditekan.

Jika tombol on/off (6) ditekan singkat dan tidak terlalu kuat, kecepatan putaran akan menjadi rendah. Tekanan yang lebih besar mengakibatkan kecepatan putaran yang lebih tinggi.

Petunjuk pengoperasian

- ▶ **Pasang perkakas listrik pada mur/sekrup hanya saat dalam keadaan mati.** Alat sisipan yang berputar dapat tergelincir.

Torsi yang tercapai tergantung pada durasi getaran. Torsi maksimal yang didapat adalah hasil jumlah seluruh torsi yang dihasilkan oleh getaran. Torsi maksimal akan tercapai setelah durasi getaran berlangsung selama 6–10 detik. Kemudian, torsi hampir tidak dapat diperbesar lagi. Lamanya durasi getaran akan ditentukan untuk setiap torsi yang diperlukan. Torsi yang didapat harus selalu diperiksa dengan kunci torsi.

Penyekrupan dengan dudukan yang kukuh, elastis, atau empuk

Jika, dalam uji coba, torsi yang dicapai dalam deretan getaran diukur dan dimuat ke diagram, kurva grafik torsi akan diperoleh. Ketinggian grafik tersebut menggambarkan torsi maksimal yang tercapai, tanjakan grafik tersebut menggambarkan lamanya waktu hingga tercapai torsi tersebut.

Grafik momen putar tergantung pada faktor-faktor berikut:

- kekuatan baut/mur
- jenis lapisan pada baut (ring pelat, ring pegas piring, seal)
- kekuatan benda yang akan dihubungkan dengan baut atau sekrup

- keadaan pelumasan pada baut atau sekrup

Berdasarkan hal tersebut penggunaannya adalah sebagai berikut:

- **Dudukan kukuh** terdapat pada penyekrupan logam pada logam dengan memakai ring pelat. Setelah waktu penggunaan getaran yang relatif pendek tercapai momen putar maksimal (tanjakan grafik yang tajam). Penggunaan getaran terlalu lama yang tidak diperlukan hanya akan merusak mesin.
- **Dudukan pegaster** terdapat pada penyekrupan logam pada logam yang memakai ring pegas, ring pegas piring, baut stud atau baut/mur dengan dudukan kerucut serta menggunakan ekstensi.
- **Dudukan empuk** terdapat pada penyekrupan misalnya logam pada kayu atau jika menggunakan lead/fibre disc atau sebagai alas.

Pada dudukan pegas atau lunak, torsi maksimal lebih rendah daripada pada dudukan kuah. Selain itu diperlukan waktu getaran yang lebih lama.

Kelas daya tahan menurut DIN 267	Baut-baut dengan daya tahan standar					Baut-baut dengan daya tahan tinggi		
	3.6	4.6	5.6	5.8	6.8	8.8	10.9	12.9
M12	22.6	30	37.6	50	60	80	113	135
M14	36	48	60	79	95	130	180	215
M16	55	73	92	122	147	196	275	330
M18	81	110	135	180	215	290	405	485
M20	115	155	190	255	305	410	580	690

Tips

Sebelum memutar masuk sekrup yang besar dan panjang ke dalam bahan yang keras, buat lubang bor terlebih dulu dengan diameter inti ulir sekitar 2/3 dari panjang sekrup.

Petunjuk: Perhatikan agar benda-benda kecil dari logam tidak masuk ke dalam perkakas listrik.

Setelah digunakan dalam waktu yang lama dengan kecepatan rendah, biarkan perkakas listrik beroperasi dengan putaran maksimal pada kecepatan idle sekitar 3 menit agar menjadi dingin..

Petunjuk untuk penanganan baterai yang optimal

Lindungi baterai dari kelembapan dan air.

Simpan baterai hanya pada rentang suhu antara -20 °C hingga 50 °C. Janganlah meletakkan baterai di dalam mobil, misalnya pada musim panas.

Waktu pengoperasian yang berkurang secara signifikan setelah pengisian daya menunjukkan bahwa baterai telah habis dan perlu diganti.

Perhatikan petunjuk untuk membuang.

Perawatan dan servis

Perawatan dan pembersihan

- ▶ **Sebelum melakukan semua pekerjaan pada perkakas listrik (misalnya merawat, mengganti alat kerja, dsb.) serta selama transpor dan penyimpanan, keluarkanlah baterai dari perkakas listrik.** Terdapat risiko cedera apabila tombol untuk menghidupkan dan mematikan dioperasikan tanpa sengaja.
- ▶ **Perkakas listrik dan lubang ventilasi harus selalu dibersihkan agar perkakas dapat digunakan dengan baik dan aman.**

Layanan pelanggan dan konsultasi penggunaan

Layanan pelanggan Bosch menjawab semua pertanyaan Anda tentang reparasi dan perawatan serta tentang suku cadang produk ini. Gambaran teknis (exploded view) dan informasi mengenai suku cadang dapat ditemukan di:

www.bosch-pt.com

Tim konsultasi penggunaan Bosch akan membantu Anda menjawab pertanyaan seputar produk kami beserta aksesoriya.

www.powertool-portal.de, portal internet untuk perajin dan tukang.

Jika Anda hendak menanyakan sesuatu atau memesan suku cadang, selalu sebutkan nomor model yang terdiri atas 10 angka dan tercantum pada label tipe produk.

Indonesia

PT Robert Bosch
 Palma Tower 10th Floor
 Jalan RA Kartini II-S Kaveling 6
 Pondok Pinang, Kebayoran Lama
 Jakarta Selatan 12310
 Tel.: (021) 3005 5800
 Fax: (021) 3005 5801
 E-Mail: boschpowertools@id.bosch.com
 www.bosch-pt.co.id

Transpor

Pada baterai-baterai li-ion yang digunakan diterapkan persyaratan terkait peraturan-peraturan tentang bahan-bahan yang berbahaya. Baterai-baterai dapat diangkut oleh penguasanya tanpa pembatasan lebih lanjut di jalan.

Pada pengiriman oleh pihak ketiga (misalnya transportasi udara atau perusahaan ekspedisi) harus ditaati syarat-syarat terkait kemasan dan pemberian tanda. Dalam hal ini, diperlukan konsultasi dengan ahli bahan-bahan berbahaya saat mengatur barang pengiriman.

Kirimkan baterai hanya jika housing-nya tidak rusak. Tutup bagian-bagian yang terbuka dan kemas baterai agar tidak bergerak-gerak di dalam kemasan. Taatilah peraturan-peraturan nasional lainnya yang mungkin lebih rinci yang berlaku di negara Anda.

Cara membuang



Perkakas listrik, baterai, aksesoris dan kemasan harus didaur ulang dengan cara yang ramah lingkungan.



Jangan membuang perkakas listrik, aki/baterai ke dalam sampah rumah tangga!

Hanya untuk negara Uni Eropa:

Berdasarkan pedoman Eropa Directive 2012/19/EU, alat listrik yang tidak lagi dapat digunakan dan berdasarkan pedoman Eropa Directive 2006/66/EC, baterai yang rusak atau yang telah dipakai harus dikumpulkan secara terpisah dan didaur ulang dengan cara yang ramah lingkungan.

Baterai:

Li-ion:

Perhatikanlah petunjuk-petunjuk dalam bab Transpor (lihat „Transpor“, Halaman 37).

Tiếng Việt

Hướng dẫn an toàn

Hướng dẫn an toàn chung cho dụng cụ điện

⚠ CẢNH BÁO

Hãy đọc toàn bộ các cảnh báo an toàn, hướng dẫn,

hình ảnh và thông số kỹ thuật được cung cấp cho dụng cụ điện cầm tay này. Không tuân thủ mọi hướng dẫn được liệt kê dưới đây có thể bị điện giật, gây cháy và /hay bị thương tật nghiêm trọng.

Hãy giữ tất cả tài liệu về cảnh báo và hướng dẫn để tham khảo về sau.

Thuật ngữ "dụng cụ điện cầm tay" trong phần cảnh báo là đề cập đến sự sử dụng dụng cụ điện cầm tay của bạn, loại sử dụng điện nguồn (có dây cắm điện) hay vận hành bằng pin (không dây cắm điện).

Khu vực làm việc an toàn

- ▶ **Giữ nơi làm việc sạch và đủ ánh sáng.** Nơi làm việc bừa bộn và tối tăm dễ gây ra tai nạn.
- ▶ **Không vận hành dụng cụ điện cầm tay trong môi trường dễ gây nổ, chẳng hạn như nơi có chất lỏng dễ cháy, khí đốt hay rác.** Dụng cụ điện cầm tay tạo ra các tia lửa nên có thể làm rác bén cháy hay bốc khói.
- ▶ **Không để trẻ em hay người đến xem đứng gần khi vận hành dụng cụ điện cầm tay.** Sự phân tâm có thể gây ra sự mất điều khiển.

An toàn về điện

- ▶ **Phích cắm của dụng cụ điện cầm tay phải thích hợp với ổ cắm.** Không bao giờ được cài biến lại phích cắm dưới mọi hình thức. Không được sử dụng phích tiếp hợp nối tiếp đất (dây mát). Phích cắm nguyên bản và ổ cắm đúng loại sẽ làm giảm nguy cơ bị điện giật.
- ▶ **Tránh không để thân tiếp xúc với đất hay các vật có bề mặt tiếp đất như đường ống, lò sưởi, hàng rào và tủ lạnh.** Có nhiều nguy cơ bị điện giật hơn nếu cơ thể bạn bị tiếp hay nối đất.
- ▶ **Không được để dụng cụ điện cầm tay ngoài mưa hay ở tình trạng ẩm ướt.** Nước vào máy sẽ làm tăng nguy cơ bị điện giật.
- ▶ **Không được lạm dụng dây dẫn điện.** Không bao giờ được nắm dây dẫn để xách, kéo hay rút phích cắm dụng cụ điện cầm tay. Không để dây gần nơi có nhiệt độ cao, dầu nhớt, vật nhọn bén và bộ phận chuyển động. Làm hỏng hay cuộn rối dây dẫn làm tăng nguy cơ bị điện giật.
- ▶ **Khi sử dụng dụng cụ điện cầm tay ngoài trời, dùng dây nối thích hợp cho việc sử dụng**

ngៅ trời. Sử dụng dây nối thích hợp cho việc sử dụng ngoài trời làm giảm nguy cơ bị điện giật.

- ▶ **Nếu việc sử dụng dụng cụ điện cầm tay ở nơi ẩm ướt là không thể tránh được, dùng thiết bị ngắt mạch tự động (RCD) bảo vệ nguồn.** Sử dụng thiết bị ngắt mạch tự động RCD làm giảm nguy cơ bị điện giật.

An toàn cá nhân

- ▶ **Hãy tỉnh táo, biết rõ mình đang làm gì và hãy sử dụng ý thức khi vận hành dụng cụ điện cầm tay.** Không sử dụng dụng cụ điện cầm tay khi đang mệt mỏi hay đang bị tác động do chất gây nghiện, rượu hay được phẩm gây ra. Một thoáng mất tập trung khi đang vận hành dụng cụ điện cầm tay có thể gây thương tích nghiêm trọng cho bản thân.
- ▶ **Sử dụng trang bị bảo hộ cá nhân.** Luôn luôn đeo kính bảo vệ mắt. Trang bị bảo hộ như khẩu trang, giày chống trượt, nón bảo hộ, hay dụng cụ bảo vệ tai khi được sử dụng đúng nơi đúng chỗ sẽ làm giảm nguy cơ thương tật cho bản thân.
- ▶ **Phòng tránh máy khởi động bất ngờ.** Bảo đảm công tắc máy ở vị trí tắt trước khi cắm vào nguồn điện và/hay lắp pin vào, khi nhắc máy lên hay khi mang xách máy. Ngáng ngón tay vào công tắc máy để xách hay kích hoạt dụng cụ điện cầm tay khi công tắc ở vị trí mở dễ dẫn đến tai nạn.
- ▶ **Lấy mọi chìa hay khóa điều chỉnh ra trước khi mở điện dụng cụ điện cầm tay.** Khóa hay chìa còn gắn dính vào bộ phận quay của dụng cụ điện cầm tay có thể gây thương tích cho bản thân.
- ▶ **Không rướn người.** Luôn luôn giữ tư thế đứng thích hợp và thăng bằng. Điều này tạo cho việc điều khiển dụng cụ điện cầm tay tốt hơn trong mọi tình huống bất ngờ.
- ▶ **Trang phục thích hợp.** Không mang quần áo rộng lủng thụng hay mang trang sức. Giữ tóc và quần áo xa khỏi các bộ phận chuyển động. Quần áo rộng lủng thụng, đồ trang sức hay tóc dài có thể bị cuốn vào các bộ phận chuyển động.
- ▶ **Nếu có các thiết bị đi kèm để nối máy hút bụi và các phụ kiện khác, bảo đảm các thiết bị này được nối và sử dụng tốt.** Việc sử dụng các thiết bị gom hút bụi có thể làm giảm các độ hại liên quan đến bụi gây ra.
- ▶ **Không để thói quen do sử dụng thường xuyên dụng cụ khiến bạn trở nên chủ quan và bỏ qua các quy định an toàn dụng cụ.** Một hành vi bất cẩn có thể gây ra thương tích nghiêm trọng chỉ trong tích tắc.

Sử dụng và bảo dưỡng dụng cụ điện cầm tay

- ▶ **Không được ép máy.** Sử dụng dụng cụ điện cầm tay đúng loại theo đúng ứng dụng của

bạn. Dụng cụ điện cầm tay đúng chức năng sẽ làm việc tốt và an toàn hơn theo đúng tiến độ mà máy được thiết kế.

- ▶ **Không sử dụng dụng cụ điện cầm tay nếu như công tắc không tắt và mở được.** Bất kỳ dụng cụ điện cầm tay nào mà không thể điều khiển được bằng công tắc là nguy hiểm và phải được sửa chữa.
 - ▶ **Rút phích cắm ra khỏi nguồn điện và/hay pin ra khỏi dụng cụ điện cầm tay nếu có thể tháo được, trước khi tiến hành bất kỳ điều chỉnh nào, thay phụ kiện, hay cất dụng cụ điện cầm tay.** Các biện pháp ngăn ngừa như vậy làm giảm nguy cơ dụng cụ điện cầm tay khởi động bất ngờ.
 - ▶ **Cất giữ dụng cụ điện cầm tay không dùng tới nơi trẻ em không lấy được và không cho người chưa từng biết dụng cụ điện cầm tay hay các hướng dẫn này sử dụng dụng cụ điện cầm tay.** Dụng cụ điện cầm tay nguy hiểm khi ở trong tay người chưa được chỉ cách sử dụng.
 - ▶ **Bảo quản dụng cụ điện cầm tay và các phụ kiện.** Kiểm tra xem các bộ phận chuyển động có bị sai lệch hay kẹt, các bộ phận bị rạn nứt và các tình trạng khác có thể ảnh hưởng đến sự vận hành của máy. Nếu bị hư hỏng, phải sửa chữa máy trước khi sử dụng. Nhiều tai nạn xảy ra do bảo quản dụng cụ điện cầm tay tồi.
 - ▶ **Giữ các dụng cụ cất bén và sạch.** Bảo quản đúng cách các dụng cụ cất có cạnh cất bén làm giảm khả năng bị kẹt và dễ điều khiển hơn.
 - ▶ **Sử dụng dụng cụ điện cầm tay, phụ kiện, đầu cài v. v., đúng theo các chỉ dẫn này, hãy lưu ý đến điều kiện làm việc và công việc phải thực hiện.** Sự sử dụng dụng cụ điện cầm tay khác với mục đích thiết kế có thể tạo nên tình huống nguy hiểm.
 - ▶ **Giữ tay cầm và bề mặt nắm luôn khô ráo, sạch sẽ và không dính dầu mỡ.** Tay cầm và bề mặt nắm trơn trượt không đem lại thao tác an toàn và kiểm soát dụng cụ trong các tình huống bất ngờ.
- #### **Sử dụng và bảo quản dụng cụ dùng pin**
- ▶ **Chỉ được sạc pin lại với bộ nạp điện do nhà sản xuất chỉ định.** Bộ nạp điện thích hợp cho một loại pin có thể gây nguy cơ cháy khi sử dụng cho một loại pin khác.
 - ▶ **Chỉ sử dụng dụng cụ điện cầm tay với loại pin được thiết kế đặt biệt dành riêng cho máy.** Sử dụng bất cứ loại pin khác có thể dẫn đến thương tật hay cháy.
 - ▶ **Khi không sử dụng pin, để cách xa các vật bằng kim loại như kẹp giấy, tiền xu, chìa khóa, đinh, ốc vít hay các đồ vật kim loại nhỏ khác, thứ có thể tạo sự nối tiếp từ một đầu**

cực với một đầu cực khác. Sự chập mạch của các đầu cực với nhau có thể gây bùng hay cháy.

- ▶ **Bảo quản ở tình trạng tối, dung dịch từ pin có thể tủa ra; tránh tiếp xúc.** Nếu vô tình chạm phải, hãy xối nước để rửa. Nếu dung dịch vào mắt, cần thêm sự hỗ trợ của y tế. Dung dịch tiết ra từ pin có thể gây ngứa hay bỏng.
- ▶ **Không được sử dụng bộ pin hoặc dụng cụ đã bị hư hại hoặc bị thay đổi.** Pin hỏng hoặc bị thay đổi có thể gây ra những tác động không lường trước được như cháy nổ hoặc nguy cơ thương tích.
- ▶ **Không đặt bộ pin hoặc dụng cụ ở gần lửa hoặc nơi quá nhiệt.** Tiếp xúc với lửa hoặc nhiệt độ cao trên 130°C có thể gây nổ.
- ▶ **Tuân thủ tất cả các hướng dẫn nạp và không nạp bộ pin hay dụng cụ ở bên ngoài phạm vi nhiệt độ đã được quy định trong các hướng dẫn.** Nạp không đúng cách hoặc ở nhiệt độ ngoài phạm vi nạp đã quy định có thể làm hư hại pin và gia tăng nguy cơ cháy.

Bảo dưỡng

- ▶ **Đưa dụng cụ điện cầm tay của bạn đến thợ chuyên môn để bảo dưỡng, chỉ sử dụng phụ tùng đúng chủng loại để thay.** Điều này sẽ đảm bảo sự an toàn của máy được giữ nguyên.
- ▶ **Không bao giờ sửa chữa các bộ pin đã hư hại.** Chỉ cho phép nhà sản xuất hoặc các nhà cung cấp dịch vụ có ủy quyền thực hiện dịch vụ sửa chữa cho các bộ pin.

Các hướng dẫn an toàn cho tua-vít

- ▶ **Chỉ cầm dụng cụ điện tại các bề mặt cầm nắm có cách điện, khi thực hiện một thao tác tại vị trí mà dụng cụ kẹp có thể tiếp xúc với dây điện ngầm.** Dụng cụ kẹp tiếp xúc với dây có điện có thể làm cho các phần kim loại hở của dụng cụ điện cầm tay có điện và có thể gây ra điện giật cho người vận hành.
- ▶ **Dùng thiết bị dò tìm thích hợp để xác định nếu có các công trình công cộng lắp đặt ngầm trong khu vực làm việc hay liên hệ với Cty công trình công cộng địa phương để nhờ hỗ trợ.** Đụng chạm đường dẫn điện có thể gây ra hỏa hoạn và điện giật. Làm hư hại đường dẫn khí ga có thể gây nổ. Làm thủng ống dẫn nước có thể làm hư hại tài sản hay có thể gây ra điện giật.
- ▶ **Giữ chặt dụng cụ điện.** Khi siết chặt và nới lỏng các vít, những mô-men phản ứng cao có thể xuất hiện trong thời gian ngắn.
- ▶ **Kẹp chặt vật gia công.** Vật gia công được kẹp bằng một thiết bị kẹp hay bằng ê-tô thì vững chắc hơn giữ bằng tay.
- ▶ **Luôn luôn đợi cho máy hoàn toàn ngừng hẳn trước khi đặt xuống.** Dụng cụ lắp vào máy có

thể bị kẹp chặt dẫn đến việc dụng cụ điện cầm tay bị mất điều khiển.

- ▶ **Trong trường hợp pin bị hỏng hay sử dụng sai cách, hơi nước có thể bốc ra.** Hãy làm cho thông thoáng khí và trong trường hợp bị đau phải nhờ y tế chữa trị. Hơi nước có thể gây ngứa hệ hô hấp.
- ▶ **Không được tháo pin ra.** Nguy cơ bị chập mạch.
- ▶ **Pin có thể bị hư hại bởi các vật dụng nhọn như đinh hay tuốc-nơ-vít hoặc bởi các tác động lực từ bên ngoài.** Nó có thể dẫn tới đoản mạch nội bộ và làm pin bị cháy, bốc khói, phát nổ hoặc quá nóng.
- ▶ **Chỉ sử dụng pin trong các sản phẩm của nhà sản xuất.** Chỉ bằng cách này, pin sẽ được bảo vệ tránh nguy cơ quá tải.



Bảo vệ pin không để bị làm nóng, ví dụ, chống để lâu dài dưới ánh nắng gay gắt, lửa, nước, và sự ẩm ướt. Sự nguy hiểm của nổ.

Mô Tả Sản Phẩm và Đặc Tính Kỹ Thuật



Đọc kỹ mọi cảnh báo an toàn và mọi hướng dẫn. Không tuân thủ mọi cảnh báo và hướng dẫn được liệt kê dưới đây có thể bị điện giật, gây cháy và / hay bị thương tật nghiêm trọng.

Xin lưu ý các hình minh hoạt trong phần trước của hướng dẫn vận hành.

Sử dụng đúng cách

Máy được thiết kế để tháo hoặc bắt vít và bu-loong cũng như để siết hay tháo đai ốc trong phạm vi kích cỡ tương ứng.

Các bộ phận được minh họa

Sự đánh số các biểu trưng của sản phẩm là để tham khảo hình minh họa của máy trên trang hình ảnh.

- (1) Phần lắp dụng cụ
- (2) Gạc vận chuyển đổi chiều quay
- (3) Pin ^{A)}
- (4) Núm tháo pin ^{A)}
- (5) Đèn „PowerLight“
- (6) Công tắc Tắt/Mở
- (7) Tay nắm (bề mặt nắm cách điện)
- (8) Dụng cụ ứng dụng (vd. khẩu hay đầu ống)

A) **Phụ tùng được trình bày hay mô tả không phải là một phần của tiêu chuẩn hàng hóa được giao kèm theo sản phẩm. Bạn có thể tham khảo tổng thể các loại phụ tùng, phụ kiện trong chương trình phụ tùng của chúng tôi.**

Thông số kỹ thuật

Máy Bật Vít Pin Đập		GDS 18 V-Li HT
Mã số máy		3 601 JB1 3..
Điện thế danh định	V=	18
Tốc độ không tải	min ⁻¹	0–1 900
Tần suất đập	min ⁻¹	0–2 100
lực xoắn tối đa, ứng dụng cho việc bắt vít vào vật rắn chắc dựa theo tiêu chuẩn ISO 5393	Nm	650
Ø Vít máy	mm	M12–M20
Phần lắp dụng cụ		■ ½"
Trọng lượng theo Qui trình EPTA-Procedure 01:2014	kg	2,7–3,2 ^{A)}
nhiệt độ môi trường cho phép		
– trong quá trình sạc điện	°C	0... +45
– khi vận hành ^{B)} và khi bảo quản	°C	-20... +50
pin được khuyến dùng		GBA 18V.. GBA 18V...W
thiết bị nạp được giới thiệu		GAL 18...W ^{C)} GAL 18V.. GAX 18V-30 AL 1820 CV AL 1860 CV GAL 1880 CV GAL 3680 CV

A) tùy vào loại pin lốc đang sử dụng

B) hiệu suất giới hạn ở nhiệt độ <0 °C

C) chỉ dành cho pin quy nạp

Sự lắp vào

- ▶ **Trước khi tiến hành bất cứ công việc gì với máy (ví dụ bảo dưỡng, thay dụng cụ v.v..) cũng như khi vận chuyển hay lưu kho, tháo pin ra khỏi dụng cụ điện.** Có nguy cơ gây thương tích khi vô tình làm kích hoạt công tắc Tắt/Mở.

Tháo Pin

Hướng dẫn: Pin đã được sạc một phần. Để bảo đảm đầy đủ điện dung, nạp điện hoàn toàn lại cho pin trong bộ nạp điện pin trước khi sử dụng cho lần đầu tiên.

Pin Li-Ion hợp khối có thể nạp điện bất cứ lúc nào mà không làm giảm tuổi thọ của pin. Sự gián đoạn trong quá trình nạp điện không làm hư hại pin hợp khối.

Pin Li-Ion được bảo vệ ngăn sự phóng điện quá lớn nhờ vào "Electronic Cell Protection (ECP)". Nếu pin bị phóng điện, dụng cụ điện cầm tay sẽ được ngắt bởi một mạch bảo vệ: Dụng cụ điện không chuyển động nữa.

- ▶ **Có nguy cơ gây thương tích khi vô tình làm kích hoạt công tắc Tắt/Mở.** Pin có thể bị hỏng.

Đèn báo trạng thái nạp pin

Ba đèn LED màu xanh của màn hình hiển thị tình trạng sạc pin chỉ ra tình trạng sạc của pin (3). Vì lý do an toàn, ta chỉ có thể kiểm tra trạng thái của tình trạng nạp điện khi máy đã ngừng hoạt động hoàn toàn.

Để hiển thị tình trạng nạp, bạn hãy nhấn nút để hiển thị mức sạc. Điều này cũng có thể thực hiện khi ắc quy được tháo ra (3).

LED	Điện dung
Sáng liên tục 3 x màu xanh lá	≥ 2/3
Sáng liên tục 2 x màu xanh lá	≥ 1/3
Sáng liên tục 1 x màu xanh lá	< 1/3
Đèn nháy 3 lần màu xanh	Sự Dự Phòng
Đèn LED không sáng sau khi nhấn nút để hiển thị mức sạc có nghĩa là pin bị hỏng và phải được thay thế.	

Tháo pin ra

Pin (3) có hai mức khóa, có nhiệm vụ ngăn ngừa pin bị rơi ra do vô ý bấm phải nút tháo pin (4). Cứ khi nào pin còn được lắp trong dụng cụ điện, nó vẫn được giữ nguyên vị trí nhờ vào chốt lò xo.

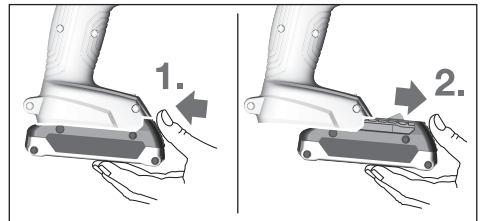

Để tháo pin (3) bạn hãy ấn nút tháo (4) và đẩy pin xuống về phía trước ra khỏi dụng cụ điện cầm tay. **Không dùng sức.**

Thay Dụng Cụ (xem hình A)

- ▶ **Trước khi tiến hành bất cứ công việc gì với máy (ví dụ bảo dưỡng, thay dụng cụ v.v..) cũng như khi vận chuyển hay lưu kho, tháo pin ra khỏi dụng cụ điện.** Có nguy cơ gây thương tích khi vô tình làm kích hoạt công tắc Tắt/Mở.
- ▶ **Thường xuyên vệ sinh các lỗ thông khí của dụng cụ điện cầm tay.** Quạt của mô tơ có thể hút bụi bẩn vào trong vỏ ngoài và việc tích tụ quá mức mặt kim loại có thể gây ra các rủi ro điện giật.

- ▶ **Khi lắp phụ tùng, hãy đảm bảo rằng nó đã khớp với phần lắp dụng cụ.** Khi dụng cụ ứng dụng không được gắn chắc chắn vào phần lắp dụng cụ, nó có thể tuột ra trong lúc ứng dụng.

Hãy đẩy phụ tùng (8) lên hình vuông của phần lắp dụng cụ (1).

Tùy theo hệ thống mà phụ tùng (8) khớp với phần lắp dụng cụ (1) bằng một khe hở; điều này không ảnh hưởng đến chức năng/độ an toàn.

Vận Hành

Cách Thức Hoạt Động

Phần lắp dụng cụ (1) có phụ tùng được truyền động bằng một động cơ điện qua hộp số và đập cơ học.

Quá trình làm việc được chia làm hai giai đoạn:

Vặn vít và **Siết chặt** (Va đập cơ học đang hoạt động).

Sự đập cơ học có tác động ngay khi việc bắt vít vào đã chặt cứng và vì vậy tải trọng được chuyển đặt lên mô-tơ. Các trường hợp ứng dụng có kết quả theo tương ứng như sau: Khi tháo vít hay đai ốc ra, qui trình chuyển đổi ngược lại.

Bắt Đầu Vận Hành

Tháo Pin

Bạn đặt gạc vặn chuyển đổi chiều quay (2) lên vị trí giữa, để tránh không vô tình bật dụng cụ điện cầm tay.

Hãy đẩy pin đã sạc (3) từ phía trước vào chân của dụng cụ điện cầm tay, cho đến khi pin được khóa an toàn.

Điều chỉnh hướng xoay (xem hình B)

Với gạc vặn chuyển đổi chiều quay (2) bạn có thể thay đổi hướng xoay của dụng cụ điện. Tuy nhiên, việc này không thực hiện được khi công tắc Tắt/Mở được nhấn (6).

Xoay theo chiều kim đồng hồ: Để vặn các vít và siết các đai ốc hãy nhấn gạc vặn chuyển đổi chiều quay (2) sang bên trái cho tới cỡ chặn.

Xoay ngược chiều kim đồng hồ: Để gỡ lỏng hoặc tháo các vít và đai ốc hãy nhấn gạc vặn chuyển đổi chiều quay (2) sang bên phải cho tới cỡ chặn.

Bật Mở và Tắt

Để **vận hành thử** dụng cụ điện hãy nhấn công tắc Tắt/Mở (6) và nhấn giữ.

Đèn (5) bật sáng khi nhấn nhẹ hoặc nhấn hoàn toàn công tắc Tắt/Mở (6) và cho phép chiếu sáng khu vực làm việc trong các điều kiện ánh sáng không tốt.

Để tắt máy, **nhả** công tắc Tắt/Mở (6) ra.

Điều chỉnh tốc độ

Bạn có thể điều tiết liên tục số vòng quay của dụng cụ điện đã bật, tùy vào việc bạn nhấn công tắc Tắt/Mở như thế nào (6).

Nhấn nhẹ trên công tắc Tắt/Mở (6) sẽ kích hoạt số vòng quay thấp. Tăng lực nhấn lên công tắc làm tăng tốc độ quay.

Hướng Dẫn Sử Dụng

- ▶ **Chỉ đặt dụng cụ điện đã tắt lên đai ốc/vít.**

Dụng cụ đang quay có thể bị tuột ra.

Momen xoắn tùy thuộc vào khoảng thời gian va đập. Momen xoắn đạt mức tối đa được tạo nên từ tổng momen xoắn riêng biệt được hoàn thành qua sự va đập. Mô men xoắn tối đa đạt được sau khoảng thời gian đập 6–10 giây. Sau khoảng thời gian này, lực siết chặt chỉ tăng thêm ở mức tối thiểu.

Khoảng thời gian đập được xác định cho từng lực siết riêng lẻ cần có. Để biết lực siết thực tế đạt được, luôn luôn kiểm tra bằng một cô-lê sử dụng lực xoắn.

Vặn vít với điểm tựa cứng, có lò xo hoặc mềm

Nếu mô-men xoắn đạt được theo trình tự va đập được đo và được truyền tới biểu đồ, bạn sẽ thấy đường cong biến thiên của lực xoắn. Chiều cao của đường cong tương ứng với lực xoắn tối đa có thể đạt được, và đường đi xuống thể hiện khoảng thời gian trong đó động thái này hoàn thành.

Đường biến thiên của lực xoắn dựa trên các yếu tố sau:

- Tính chất bền của vít/đai ốc
- Loại đệm trợ lực (vòng lót, đệm lò xo, vòng đệm kín)
- Tính chất bền của vật liệu được bắt ghép bằng vít/bu-loong
- Tình trạng bôi trơn tại nơi bắt vít/bu-loong

Các trường hợp ứng dụng có kết quả theo tương ứng như sau:

- **Điểm tựa cứng** được sử dụng tại các mối bắt vít kim loại trên kim loại khi sử dụng các vòng đệm. Sau thời gian đập tương đối ngắn, lực xoắn tối đa hoàn thành (đặt tính của đường cong đi xuống). Không cần phải có khoảng thời gian đập dài vì làm thế chỉ làm cho máy bị hỏng.
- **Điểm tựa có lò xo** được sử dụng tại các mối bắt vít kim loại trên kim loại, tuy nhiên là khi sử dụng các vòng lò xo, đệm lò xo, chốt ren hoặc vít/đai ốc với điểm tựa hình côn cũng như khi sử dụng các phần kéo dài.
- **Điểm tựa mềm** được sử dụng tại các mối bắt vít kim loại trên gỗ, hoặc khi sử dụng các đĩa sợi hoặc đĩa chì làm đệm.

Đối với điểm tựa có đệm lò xo chịu tải cũng như điểm tựa mềm, lực siết chặt tối đa thấp hơn điểm tựa cứng. Cũng như thế, đương nhiên là cần có khoảng thời gian đập dài hơn.

Thuộc tính Chứng loại theo tiêu chuẩn Đức DIN 267	Vít/Bu-loong tiêu chuẩn					Bu-loong có sức bền cao		
	3.6	4.6	5.6	5.8	6.8	8.8	10.9	12.9
M12	22.6	30	37.6	50	60	80	113	135
M14	36	48	60	79	95	130	180	215
M16	55	73	92	122	147	196	275	330
M18	81	110	135	180	215	290	405	485
M20	115	155	190	255	305	410	580	690

Mạch nước

Trước khi bắt một vít lớn, dài hơn bình thường vào vật liệu cứng, nên khoan trước một lỗ mỗi có cùng đường kính răng vít vào sâu vào khoảng 2/3 của chiều dài vít.

Lưu ý: Lưu ý không để các mảnh nhỏ kim loại lọt vào trong dụng cụ điện.

Sau một thời gian làm việc dài với tốc độ vòng quay thấp, bạn cần cho dụng cụ điện quay không tải với tốc độ tối đa trong khoảng 3 phút để làm mát.

Lưu ý để bảo quản pin tối ưu

Bảo vệ pin tránh ẩm ướt và nước.

Chỉ bảo quản pin trong tầm nhiệt độ nằm giữa -20 °C và 50. Không để pin trong ô tô vào mùa hè.

Sự giảm sút đáng kể thời gian hoạt động sau khi nạp điện chỉ rõ rằng pin hợp khối đã hết công dụng và phải được thay.

Quy trình hoạt động được chia ra làm hai giai đoạn.

Bảo Dưỡng và Bảo Quản

Bảo Dưỡng Và Làm Sạch

► **Trước khi tiến hành bất cứ công việc gì với máy (ví dụ bảo dưỡng, thay dụng cụ v.v..) cũng như khi vận chuyển hay lưu kho, tháo pin ra khỏi dụng cụ điện.** Có nguy cơ gây thương tích khi vô tình làm kích hoạt công tắc Tắt/Mở.

► **Để được an toàn và máy hoạt động đúng chức năng, luôn luôn giữ máy và các khe thông gió được sạch.**

Dịch vụ hỗ trợ khách hàng và tư vấn sử dụng

Bộ phận phục vụ hàng sau khi bán của chúng tôi trả lời các câu hỏi liên quan đến việc bảo dưỡng và sửa chữa các sản phẩm cũng như phụ tùng thay thế của bạn. Sơ đồ mô tả và thông tin về phụ tùng thay thế cũng có thể tra cứu theo dưới đây:

www.bosch-pt.com

Đội ngũ tư vấn sử dụng của Bosch sẽ giúp bạn giải đáp các thắc mắc về sản phẩm và phụ kiện.

www.powertool-portal.de, cổng thông tin điện tử cho thợ thủ công và người làm việc vật.

Trong tất cả các phản hồi và đơn đặt phụ tùng, xin vui lòng luôn luôn nhập số hàng hóa 10 chữ số theo nhãn của hàng hóa.

Việt Nam

CN CÔNG TY TNHH BOSCH VIỆT NAM TẠI TP.HCM

Tầng 14, Ngôi Nhà Đức, 33 Lê Duẩn
Phường Bến Nghé, Quận 1, Thành Phố Hồ Chí Minh

Tel.: (028) 6258 3690

Fax: (028) 6258 3692 - 6258 3694

Hotline: (028) 6250 8555

Email: tuvankhachhang-pt@vn.bosch.com

www.bosch-pt.com.vn

www.baohanhbosch-pt.com.vn

Campuchia

Công ty TNHH Robert Bosch (Campuchia)

Đơn nguyên 8BC, GT Tower, Tầng 08,
Đường 169, Tiệp Khắc Blvd, Sangkat Veal Vong,
Khan 7 Makara, Phnom Penh

VAT TIN: 100 169 511

Tel.: +855 23 900 685

Tel.: +855 23 900 660

www.bosch.com.kh

Vận chuyển

Pin có chứa Li-Ion là đối tượng phải tuân theo các qui định của Pháp Luật về Hàng Hóa Nguy Hiểm. Người sử dụng có thể vận chuyển pin hợp khối bằng đường bộ mà không cần thêm yêu cầu nào khác.

Khi được vận chuyển thông qua bên thứ ba (vd. vận chuyển bằng đường hàng không hay đại lý giao nhận), phải tuân theo các yêu cầu đặc biệt về đóng gói và dán nhãn. Phải tham vấn chuyên gia về hàng hóa nguy hiểm khi chuẩn bị gói hàng.

Chỉ gửi pin hợp khối khi vỏ ngoài không bị hư hỏng. Dán băng keo hay che kín các điểm tiếp xúc hở và đóng gói pin hợp khối theo cách sao cho pin không thể xê dịch khi nằm trong bao bì. Ngoài ra, xin vui lòng chấp hành các qui định chi tiết có thể được bổ sung thêm của quốc gia.

Sự thải bỏ



Dụng cụ điện, pin, phụ kiện và bao bì cần được tái sử dụng theo quy định về môi trường.



Bạn không được ném dụng cụ điện và pin vào thùng rác gia đình!

Chỉ dành cho các quốc gia thuộc khối Liên minh Châu Âu (EU):

Các dụng cụ điện cầm tay không còn giá trị sử dụng theo chỉ thị châu Âu 2012/19/EU và ắc quy/pin bị hỏng hoặc đã qua sử dụng theo chỉ thị số 2006/66/EG phải được thu gom riêng và có thể tái sử dụng theo luật môi trường.

Pin/ắc quy:

Li-ion:

Tuân thủ những hướng dẫn trong phần vận chuyển (xem „Vận chuyển“, Trang 42).

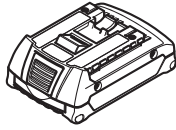
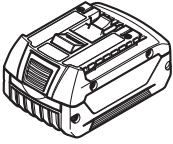

**GBA 18V..
GBA 18V... W**

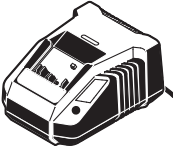

**AL 1820 CV
(14,4 / 18 V)**



**AL 1860 CV
(14,4 / 18 V)**

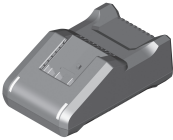

GAL 18V-40



GAL 18V-160 C



GAL 1880 CV



GAX 18V-30



GAL 3680 CV



GAL 18... W