

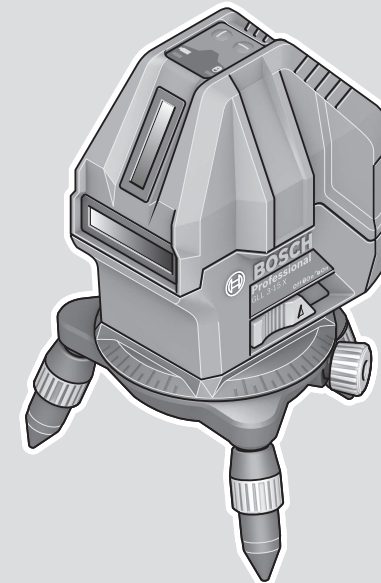

GLL 3-15 X Professional



Robert Bosch Power Tools GmbH
70538 Stuttgart
GERMANY

www.bosch-pt.com

1 609 92A 61T (2020.11) T / 46



1 609 92A 61T

- en Original instructions
- zh 正本使用说明书
- zh 原始使用說明書
- ko 사용 설명서 원본
- th หนังสือคู่มือการใช้งานฉบับต้นแบบ
- id Petunjuk-Petunjuk untuk Penggunaan Orisinal
- vi Bản gốc hướng dẫn sử dụng



English	Page	6
中文	页	11
繁體中文	頁	17
한국어	페이지	22
ไทย	หน้า	28
Bahasa Indonesia	Halaman	35
Tiếng Việt	Trang	40

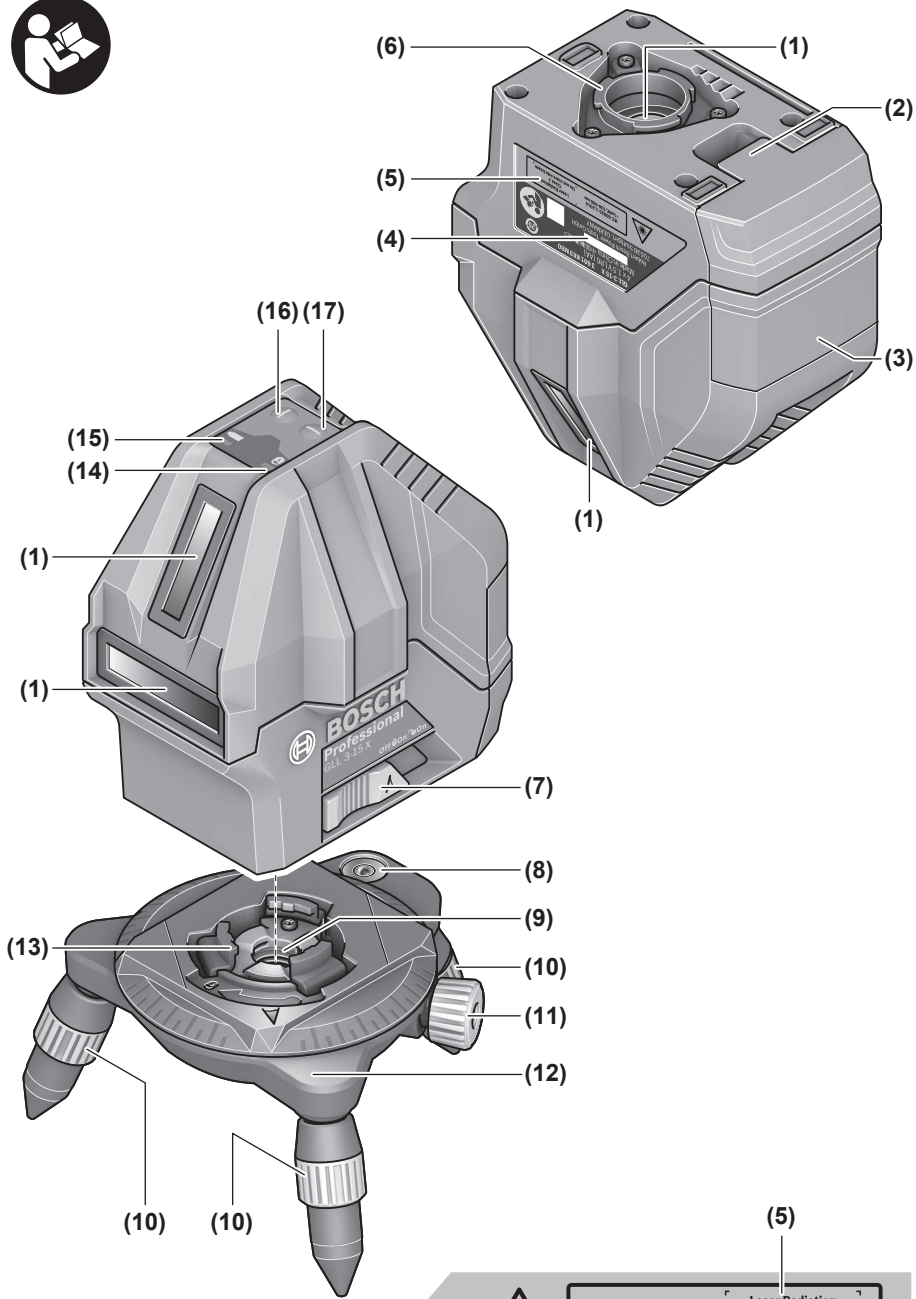

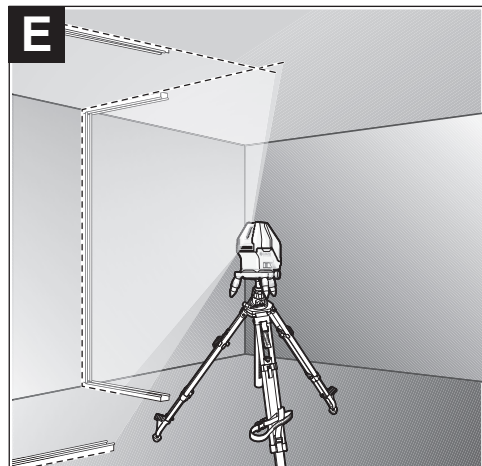
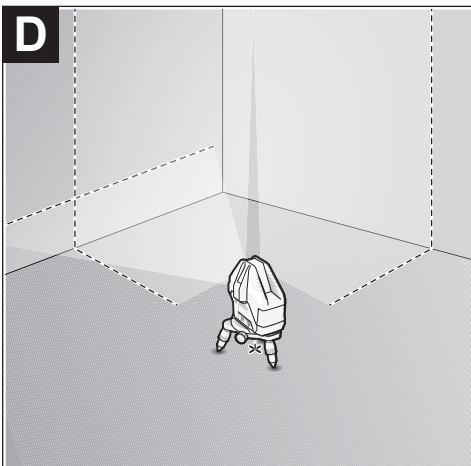
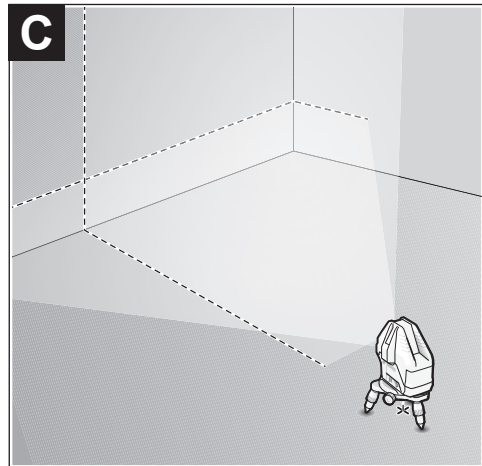
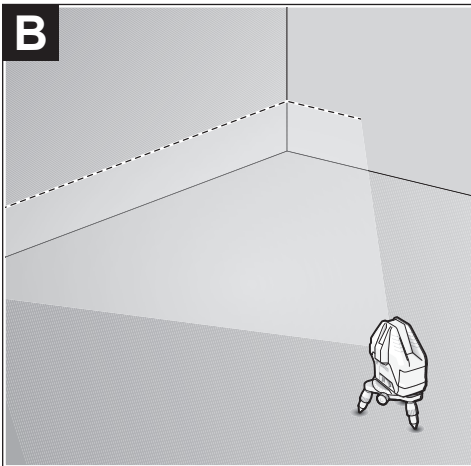
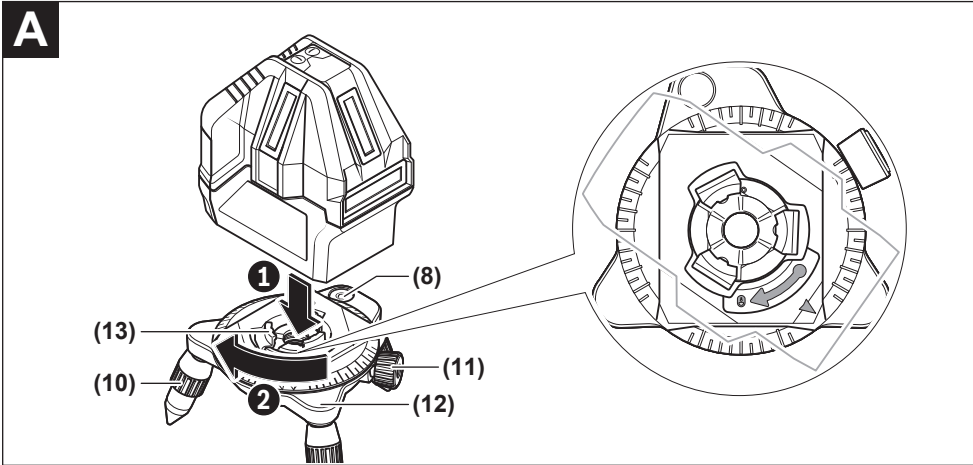

F

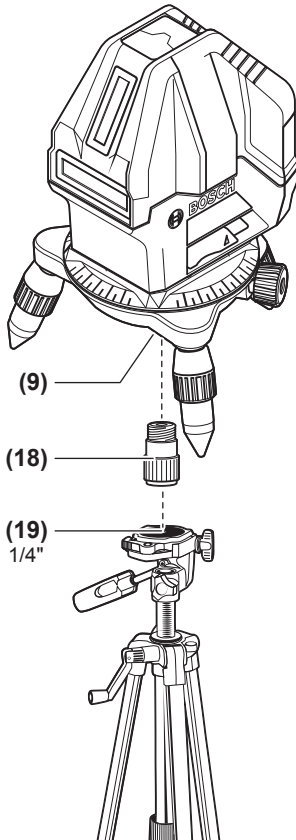

(20)
1 608 M00 05B

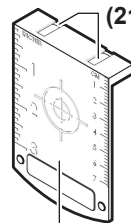

(21)
(22)
1 608 M00 05C

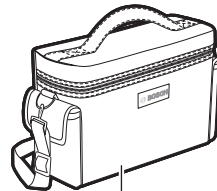

(23)

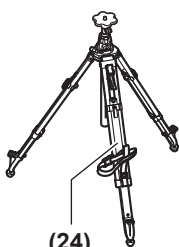

(24)
BT 300 HD
0 601 091 400

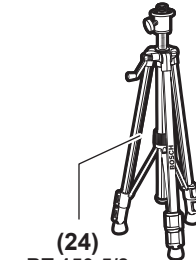

(24)
BT 150-5/8
0 601 096 CB0



(18)
1 618 C01 42A



(19)
BT 150
0 601 096 B00

English

Safety Instructions



All instructions must be read and observed in order for the measuring tool to function safely. The safeguards integrated into the measuring tool may be compromised if the measuring tool is not used in accordance with these instructions. Never make warning signs on the measuring tool unrecognisable. **SAVE THESE INSTRUCTIONS FOR FUTURE REFERENCE AND INCLUDE THEM WITH THE MEASURING TOOL WHEN TRANSFERRING IT TO A THIRD PARTY.**

- ▶ **Warning! If operating or adjustment devices other than those specified here are used or other procedures are carried out, this can lead to dangerous exposure to radiation.**
- ▶ **The measuring tool is delivered with a laser warning sign (marked in the illustration of the measuring tool on the graphics page).**
- ▶ **If the text of the laser warning label is not in your national language, stick the provided warning label in your national language over it before operating for the first time.**



Do not direct the laser beam at persons or animals and do not stare into the direct or reflected laser beam yourself. You could blind somebody, cause accidents or damage your eyes.

- ▶ **If laser radiation hits your eye, you must close your eyes and immediately turn your head away from the beam.**
- ▶ **Do not make any modifications to the laser equipment.**
- ▶ **Do not use the laser goggles (accessory) as protective goggles.** The laser goggles make the laser beam easier to see; they do not protect you against laser radiation.
- ▶ **Do not use the laser goggles (accessory) as sunglasses or while driving.** The laser goggles do not provide full UV protection and impair your ability to see colours.
- ▶ **Have the measuring tool serviced only by a qualified specialist using only original replacement parts.** This will ensure that the safety of the measuring tool is maintained.
- ▶ **Do not let children use the laser measuring tool unsupervised.** They could unintentionally blind themselves or other persons.
- ▶ **Do not use the measuring tool in explosive atmospheres which contain flammable liquids, gases or dust.** Sparks may be produced inside the measuring tool, which can ignite dust or fumes.



Keep the measuring tool and the magnetic accessories away from implants and other medical devices, e.g. pacemakers or insulin pumps. The magnets inside the measuring tool and accessories generate a field that can impair the function of implants and medical devices.

- ▶ **Keep the measuring tool and the magnetic accessories away from magnetic data storage media and magnetically sensitive devices.** The effect of the magnets inside the measuring tool and accessories can lead to irreversible data loss.

Product Description and Specifications

Please observe the illustrations at the beginning of this operating manual.

Intended Use

The measuring tool is intended for determining and checking horizontal and vertical lines and plumb points.

The measuring tool is suitable for indoor use.

Product Features

The numbering of the product features shown refers to the illustration of the measuring tool on the graphic page.

- (1) Laser beam outlet aperture
- (2) Battery compartment cover locking mechanism
- (3) Battery compartment cover
- (4) Serial number
- (5) Laser warning label
- (6) Fastening grooves of measuring tool
- (7) On/off switch
- (8) Spirit level of rotating platform
- (9) 5/8" tripod mount of rotating platform
- (10) Height adjustment screw of the rotating platform
- (11) Fine adjustment screw of the rotating platform
- (12) Rotating platform
- (13) Fastening grooves of the rotating platform
- (14) Pendulum lock indicator
- (15) Status indicator
- (16) Vertical mode button
- (17) Horizontal mode button
- (18) Tripod adapter^{a)}
- (19) 1/4" tripod^{a)}
- (20) Laser goggles^{a)}
- (21) Magnet^{a)}
- (22) Laser target plate^{a)}
- (23) Protective bag

(24) 5/8" tripod^{a)}

- a) **Accessories shown or described are not included with the product as standard. You can find the complete selection of accessories in our accessories range.**

Technical Data

Line laser	GLL 3-15 X
Article number	3 601 K63 M..
Working range ^{A)}	
– Laser lines	15 m
– Plumb point	5 m
Laser line levelling accuracy ^{B)(C)(D)}	±0.2 mm/m
Typical self-levelling range	±3°
Typical levelling time	< 4 s
Operating temperature	-10 °C to +45 °C
Storage temperature	-20 °C to +70 °C
Max. altitude	2000 m
Relative air humidity max.	90 %
Pollution degree according to IEC 61010-1	2 ^{E)}
Laser class	2
Laser type	< 1 mW, 630-650 nm
C ₆	1
Divergence	
– Laser line	1.5 mrad
– Plumb point	1.5 mrad
Tripod mount ^{F)}	5/8"
Batteries	4 × 1.5 V LR6 (AA)
Operating time approx. ^{C)}	
– With 1 laser line	24 h
– With 2 laser lines	14 h
– With 3 laser lines	10 h
Weight according to EPTA-Procedure 01:2014	0.54 kg
Dimensions (length × width × height)	
– Without rotating platform	122 × 83 × 129 mm
– With rotating platform	Dia. 151 × 203 mm

Line laser**GLL 3-15 X**

Protection rating (excluding battery compartment) IP 54 (dust and splash-proof)

- A) The working range may be reduced by unfavourable environmental conditions (e.g. direct sunlight).
- B) ex-works
- C) At **20-25 °C**
- D) The values stated presuppose normal to favourable environmental conditions (e.g. no vibration, no fog, no smoke, no direct sunlight). Extreme fluctuations in temperature can cause deviations in accuracy.
- E) Only non-conductive deposits occur, whereby occasional temporary conductivity caused by condensation is expected.
- F) Only available in combination with the rotating platform
- The serial number **(4)** on the type plate is used to clearly identify your measuring tool.

Assembly**Inserting/changing the batteries**

It is recommended that you use alkaline manganese batteries to operate the measuring tool.

To open the battery compartment cover **(3)**, press on the locking mechanism **(2)** and remove the battery compartment cover. Insert the batteries.

When inserting the batteries, ensure that the polarity is correct according to the illustration on the inside of the battery compartment.

If the status display **(15)** flashes, the batteries have to be replaced.

Always replace all the batteries at the same time. Only use batteries from the same manufacturer and which have the same capacity.

- **Take the batteries out of the measuring tool when you are not using it for a prolonged period of time.** The batteries can corrode and self-discharge during prolonged storage in the measuring tool.

Working with the Rotating Platform (see figure A)

You can use the rotating platform **(12)** to rotate the measuring tool 360° around a central, always visible plumb point. This enables you to set up the laser lines precisely, without having to change the position of the measuring tool.

Place the measuring tool on the rotating platform **(12)** so that the fastening grooves **(13)** of the rotating platform fit between the corresponding fastening grooves **(6)** on the bottom of the measuring tool. Turn the measuring tool clockwise to lock it on the rotating platform.

Unscrew the legs of the rotating platform **(12)** with the height adjustment screws **(10)**.

Roughly align the rotating platform using the spirit level **(8)**. If the measuring tool is mounted on the rotating platform **(12)**, you can use the fine adjustment screw **(11)** to align vertical laser lines precisely with reference points.

Operation

Starting Operation

- ▶ **Protect the measuring tool from moisture and direct sunlight.**
- ▶ **Do not expose the measuring tool to any extreme temperatures or fluctuations in temperature.** For example, do not leave it in a car for extended periods of time. If it has been subjected to significant fluctuations in temperature, first allow the measuring tool to adjust to the ambient temperature and then always carry out an accuracy check before continuing work (see "Accuracy Check of the Measuring Tool", page 9).
The precision of the measuring tool may be compromised if exposed to extreme temperatures or fluctuations in temperature.
- ▶ **Avoid substantial knocks to the measuring tool and avoid dropping it.** Always carry out an accuracy check before continuing work if the measuring tool has been subjected to severe external influences (see "Accuracy Check of the Measuring Tool", page 9).
- ▶ **Switch the measuring tool off when transporting it.**
The pendulum unit is locked when the tool is switched off, as it can otherwise be damaged by big movements.

Switching On/Off

To **switch on** the measuring tool, slide the on/off switch (7) to the "On" position (for working with the pendulum lock) or to the "On" position (for working with automatic levelling). The status display (15) lights up. Immediately after switching on, the measuring tool sends a horizontal laser line out of the front outlet aperture (1).

- ▶ **Do not direct the laser beam at persons or animals and do not stare into the laser beam yourself (even from a distance).**

To **switch off** the measuring tool, slide the on/off switch (7) to the "Off" position. The status indicator (15) goes out. The pendulum unit is locked when the tool is switched off.

- ▶ **Never leave the measuring tool unattended when switched on, and ensure the measuring tool is switched off after use.** Others may be blinded by the laser beam.

If the maximum permitted operating temperature of 45 °C is exceeded, the tool shuts down to protect the laser diode. Once it has cooled down, the measuring tool is operational again and can be switched back on.

Deactivating the automatic shut-off function

The measuring tool automatically switches itself off after 30 min of operation.

To deactivate the automatic shut-off, hold down either the vertical mode button (16) or the horizontal mode button (17) for 3 seconds when switching on the measuring tool. The laser beams will flash briefly after 3 seconds if the automatic shut-off function is deactivated.

To activate the automatic shut-off function, switch the measuring tool off and on again (without holding down a button).

Operating Modes

The measuring tool has several operating modes, which you can switch between at any time. The horizontal and vertical modes can be switched on and off independently of each other. After switching on, the measuring tool is in horizontal mode.

All operating modes can be selected with both automatic levelling or the pendulum lock.

Horizontal mode (see figure B)

In horizontal mode, the measuring tool sends out a horizontal laser line pointing forwards.

To switch the horizontal laser line off or on, press the horizontal mode button (17).

Vertical mode and plumb point (see figures C–D)

The measuring tool has two vertical operation modes:

- Vertical laser line forwards
 - Vertical laser line forwards and to the right-hand side
- A plumb point is additionally projected downwards in vertical mode.

To switch the vertical mode on/off or to change the vertical mode, press the vertical mode button (16) repeatedly until the required operating mode is reached.

Automatic Levelling

Working with automatic levelling

Position the measuring tool on a level, firm surface or attach it to the rotating platform (12).

For work with automatic levelling, slide the on/off switch (7) to the "On" position.

The automatic levelling function automatically compensates irregularities within the self-levelling range of $\pm 3^\circ$. The levelling is finished as soon as the laser lines stop moving.

If automatic levelling is not possible, e.g. because the surface on which the measuring tool stands deviates by more than 3° from the horizontal plane, the laser beams will flash quickly.

If this is the case, set up the measuring tool in a level position and wait for the self-levelling to take place. As soon as the measuring tool is within the self-levelling range of $\pm 3^\circ$, the laser beams will light up continuously.

In case of ground vibrations or position changes during operation, the measuring tool is automatically levelled again.

Upon levelling, check the position of the laser beams with regard to the reference points to avoid errors arising from a change in the measuring tool's position.

Working with the pendulum lock

For work with the pendulum lock, slide the on/off switch (7) to the "On" position. The pendulum lock indicator (14) lights up red and the laser lines continuously flash slowly.

For work with the pendulum lock, automatic levelling is switched off. You can hold the measuring tool freely in your hand or place it on a sloping surface. This means that the laser beams are no longer levelled and no longer necessarily run perpendicular to one another.

Accuracy Check of the Measuring Tool

Influences on Accuracy

The largest influence is exerted by the ambient temperature. In particular, temperature differences that occur from the ground upwards can refract the laser beam.

Since the temperature stratification is greatest at ground level, you should mount the measuring tool on a tripod and position it in the centre of the work surface, wherever this is possible.

In addition to external influences, device-specific influences (e.g. falls or heavy impacts) can also lead to deviations. For this reason, check the levelling accuracy each time before beginning work.

First check the height accuracy and levelling accuracy of the horizontal laser line, then the levelling accuracy of the vertical laser line.

Should the measuring tool exceed the maximum deviation during one of the tests, please have it repaired by a **Bosch** after-sales service.

Checking the Height Accuracy of the Horizontal Line

For this check, you will need a free measuring distance of **5 m** on firm ground between two walls (designated A and B).

- Mount the measuring tool close to wall A on the rotating platform (12) or a tripod (24), or place it on a firm, flat surface. Switch on the measuring tool in the mode with automatic levelling. Switch on horizontal mode and vertical mode with a laser line forwards.

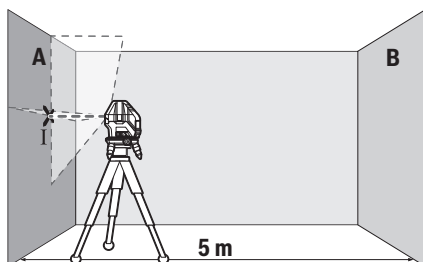

- Aim the laser at the closer wall A and allow the measuring tool to level in. Mark the middle of the point at which the laser lines cross on the wall (point I).

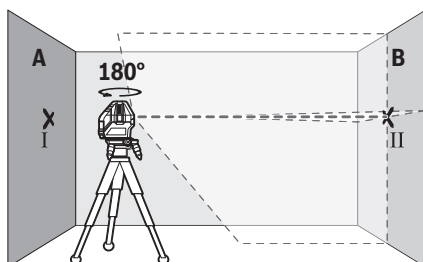

- Turn the measuring tool 180°, allow it to level in and mark the point where the laser lines cross on the opposite wall B (point II).

- Position the measuring tool – without rotating it – close to wall B, switch it on and allow it to level in.

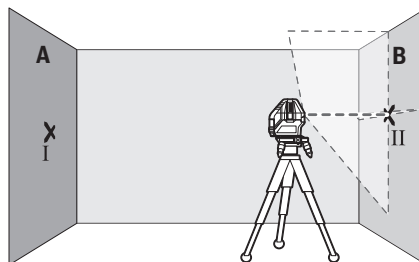

- Align the height of the measuring tool (using the tripod or by placing objects underneath as required) so that the point where the laser lines cross exactly hits the previously marked point II on wall B.

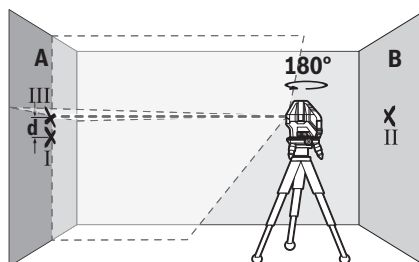

- Turn the measuring tool 180° without adjusting the height. Aim it at wall A such that the vertical laser line runs through the already marked point I. Allow the measuring tool to level in and mark the point where the laser lines cross on wall A (point III).
- The discrepancy **d** between the two marked points I and III on wall A reveals the actual height deviation of the measuring tool.

The maximum permitted deviation on the measuring distance of $2 \times 5 \text{ m} = 10 \text{ m}$ is as follows:

$10 \text{ m} \times \pm 0.2 \text{ mm/m} = \pm 2 \text{ mm}$. The discrepancy **d** between points I and III must therefore amount to no more than **2 mm**.

Checking the Level Accuracy of the Horizontal Line

For this check, you will need a free area of $5 \times 5 \text{ m}$.

- Mount the measuring tool in the middle between walls A and B on the rotating platform (12) or a tripod (24), or place it on a firm, flat surface. Switch on the measuring tool in the mode with automatic levelling. Switch on horizontal mode and allow the measuring tool to level in.

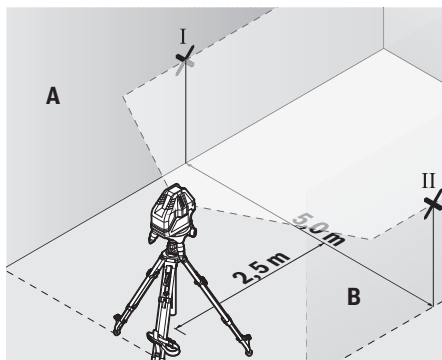

- At a distance of 2.5 m from the measuring tool, mark the centre of the laser line on both walls (point I on wall A and point II on wall B).

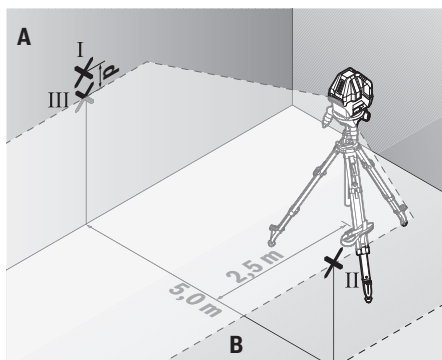

- Set up the measuring tool at a 5 m distance and rotated by 180° and allow it to level in.
- Align the height of the measuring tool (using the tripod or by placing objects underneath as required) so that the centre of the laser line exactly hits the previously marked point II on wall B.
- Mark the centre of the laser line on wall A as point III (vertically above or below point I).
- The discrepancy **d** between the two marked points I and III on wall A reveals the actual horizontal deviation of the measuring tool.

The maximum permitted deviation on the measuring distance of $2 \times 5 \text{ m} = 10 \text{ m}$ is as follows:

$10 \text{ m} \times \pm 0.2 \text{ mm/m} = \pm 2 \text{ mm}$. The discrepancy **d** between points I and III must therefore amount to no more than 2 mm.

Checking the Level Accuracy of the Vertical Line

For this check, you will need a door opening (on solid ground) which has at least 2.5 m of space either side of the door.

- Place the measuring tool 2.5 m away from the door opening on a firm, flat surface (not on the rotating platform (12) or a tripod). Switch on the measuring tool in the mode with automatic levelling. Switch on vertical

mode with a vertical laser line forwards and aim the vertical laser line at the door opening. Allow the measuring tool to level in.

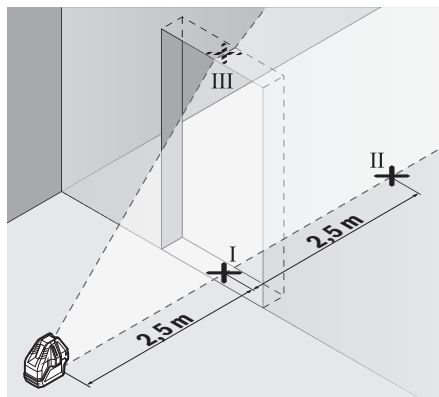

- Mark the centre of the vertical laser line on the floor of the door opening (point I), 5 m away on the other side of the door opening (point II) and on the upper edge of the door opening (point III).

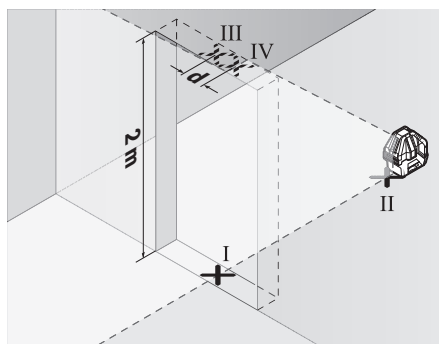

- Rotate the measuring tool 180° and position it on the other side of the door opening, directly behind point II. Allow the measuring tool to level in and align the vertical laser line in such a way that its centre passes through points I and II exactly.
- Mark the centre of the laser line on the upper edge of the door opening as point IV.
- The discrepancy **d** between the two marked points III and IV reveals the actual vertical deviation of the measuring tool.
- Measure the height of the door opening.

You can calculate the maximum permitted deviation as follows:

Doubled height of the door opening $\times 0.2 \text{ mm/m}$

Example: At a door opening height of 2 m, the maximum deviation amounts to $2 \times 2 \text{ m} \times \pm 0.2 \text{ mm/m} = \pm 0.8 \text{ mm}$. The points III and IV must therefore be no further than 0.8 mm from each other.

Working Advice

- ▶ **Only the centre of the laser point or laser line must be used for marking.** The size of the laser point/the width of the laser line changes depending on the distance.

Working with the Laser Target Plate

The laser target plate (22) improves visibility of the laser beam in unfavourable conditions and at greater distances. The reflective surface of the laser target plate (22) improves visibility of the laser line. The transparent surface enables the laser line to be seen from behind the laser target plate.

Working with the Tripod (Accessory) (see figure F)

A tripod offers a stable, height-adjustable support surface for measuring. Place the measuring tool on the rotating platform (12) to assemble the measuring tool on a tripod. Assembly on a 5/8" tripod: Place the rotating platform with the 5/8" tripod mount (9) on the thread of a commercially available 5/8" tripod (24) or a commercially available building tripod. Tighten the rotating platform using the locking screw of the tripod.

Assembly on a 1/4" tripod (see figure F): Screw the tripod adapter (18) (accessory) into the 5/8" tripod mount (9) of the rotating platform. Place the tripod adapter with the 1/4" tripod mount on the thread of a 1/4" tripod (19) or a commercially available camera tripod. Tighten the tripod adapter using the locking screw of the tripod.

Roughly align the tripod before switching on the measuring tool.

Laser Goggles (Accessory)

The laser goggles filter out ambient light. This makes the light of the laser appear brighter to the eye.

- ▶ **Do not use the laser goggles (accessory) as protective goggles.** The laser goggles make the laser beam easier to see; they do not protect you against laser radiation.
- ▶ **Do not use the laser goggles (accessory) as sunglasses or while driving.** The laser goggles do not provide full UV protection and impair your ability to see colours.

Example applications (see figures B-E)

Examples of possible applications for the measuring tool can be found on the graphics pages.

Maintenance and Service

Maintenance and Cleaning

Keep the measuring tool clean at all times.

Never immerse the measuring tool in water or other liquids. Wipe off any dirt using a damp, soft cloth. Do not use any detergents or solvents.

The areas around the outlet aperture of the laser in particular should be cleaned on a regular basis. Make sure to check for lint when doing this.

Only store and transport the measuring tool in the protective pouch (23).

If the measuring tool needs to be repaired, send it off in the protective pouch (23).

After-Sales Service and Application Service

Our after-sales service responds to your questions concerning maintenance and repair of your product as well as spare parts. You can find explosion drawings and information on spare parts at: www.bosch-pt.com

The Bosch product use advice team will be happy to help you with any questions about our products and their accessories.

In all correspondence and spare parts orders, please always include the 10-digit article number given on the nameplate of the product.

Malaysia

Robert Bosch Sdn. Bhd. (220975-V) PT/SMY
No. 8A, Jalan 13/6
46200 Petaling Jaya
Selangor
Tel.: (03) 79663194
Toll-Free: 1800 880188
Fax: (03) 79583838
E-Mail: kiathoe.chong@my.bosch.com
www.bosch-pt.com.my

You can find further service addresses at:

www.bosch-pt.com/serviceaddresses

Disposal

Measuring tools, accessories and packaging should be recycled in an environmentally friendly manner.



Do not dispose of measuring tools or batteries with household waste.

中文

安全规章



必须阅读并注意所有说明，以安全可靠地操作测量仪。如果不按照给出的说明使用测量仪，可能会影响集成在测量仪中的保护功能。测量仪上的警戒牌应保持清晰可读的状态。请妥善保存本说明书，并在转交测量仪时将本说明书一起移交。

- ▶ **小心** - 如果使用了与此处指定的操作或校准设备不同的设备，或执行了不同的过程方法，可能会导致危险的光束泄露。
- ▶ 本测量仪交付时带有一块激光警戒牌（在测量仪示意图的图形页中标记）。
- ▶ 如果激光警戒牌的文字并非本国语言，则在第一次使用前，将随附的该国语言的贴纸贴在警戒牌上。



不得将激光束指向人或动物，请勿直视激光束或反射的激光束。可能会致人炫目、引发事故或损伤眼睛。

- ▶ 如果激光束射向眼部，必须有意识地闭眼，立即从光束位置将头移开。
- ▶ 请不要对激光装置进行任何更改。
- ▶ 激光视镜（附件）不得用作护目镜。激光视镜用于更好地识别激光束；然而对激光束并没有防护作用。
- ▶ 激光视镜（附件）不得用作太阳镜或在道路交通中使用。激光视镜并不能完全防护紫外线，还会干扰对色彩的感知。
- ▶ 仅允许由具备资质的专业人员使用原装备件修理测量仪。如此才能够确保测量仪的安全性能。
- ▶ 不得让儿童在无人看管的情况下使用激光测量仪。可能意外地让他人或自己炫目。
- ▶ 请勿在有易燃液体、气体或粉尘的潜在爆炸性环境中使用测量仪。测量仪器内可能产生火花并点燃粉尘和气体。



不要将测量仪和磁性附件靠近植入物和其他医疗设备，例如心脏起搏器或胰岛素泵。测量仪和附件的磁性会产生磁场，这可能对植入物和医疗设备的功能产生不利影响。

- ▶ 让测量仪和磁性附件远离磁性数据媒体和对磁性敏感的设备。测量仪和附件的磁性作用可能会导致不可逆的数据丢失。

产品和性能说明

请注意本使用说明书开头部分的图示。

按照规定使用

测量仪用于确定和检测水平线、垂直线以及下对点。

本测量仪器适合在室内使用。

插图上的机件

机件的编号和仪器详解图上的编号一致。

- (1) 激光束发射口
- (2) 电池盒盖的固定扳扣
- (3) 电池盒盖
- (4) 序列号
- (5) 激光警戒牌
- (6) 测量仪固定凹槽
- (7) 电源开关
- (8) 旋转平台水准仪
- (9) 旋转平台5/8英寸三脚架接头
- (10) 旋转平台高度调节螺栓
- (11) 旋转平台微调螺栓
- (12) 旋转平台
- (13) 旋转平台固定凹槽

(14) 摆动止动件指示灯

(15) 状态指示灯

(16) 垂直模式按键

(17) 水平模式按键

(18) 三脚架适配器^{a)}

(19) 三脚架1/4^{''a)}

(20) 激光视镜^{a)}

(21) 磁贴^{a)}

(22) 激光靶^{a)}

(23) 保护袋

(24) 三脚架5/8^{''a)}

a) 图表或说明上提到的附件，并不包含在基本的供货范围中。本公司的附件清单中有完整的附件供应项目。

技术参数

线段激光测量仪	GLL 3-15 X
物品代码	3 601 K63 M..
工作范围 ^{A)}	
- 激光线	15米
- 下对点	5米
激光线找平准确性 ^{B)C)D)}	±0.2毫米/米
一般自调平范围	±3度
一般调平时间	< 4秒
工作温度	-10摄氏度至 +45摄氏度
仓储温度	-20摄氏度至 +70摄氏度
基准高度以上的最大使用高度	2000米
最大相对湿度	90 %
脏污程度符合IEC 61010-1	2 ^{E)}
激光等级	2
激光种类	< 1毫瓦， 630-650纳米
C ₆	1
发散角	
- 激光线	1.5毫弧度
- 下对点	1.5毫弧度
三脚架接头 ^{F)}	5/8英寸
电池	4 × 1.5伏特LR6 (AA)
运行时间大约 ^{G)}	
- 使用1束激光线	24小时
- 使用2束激光	14小时
- 使用3束激光	10小时
重量符合 EPTA- Procedure 01:2014	0.54公斤
尺寸 (长 × 宽 × 高)	
- 无旋转平台	122 × 83 × 129毫米

线段激光测量仪 **GLL 3-15 X**

- 带旋转平台 直径151 × 203毫米

防护类型 (电池盒除外) IP 54 (防尘、防溅)

- A) 工作范围可能会因为环境条件不利 (比如阳光直射) 而缩小。
- B) 出厂时的设定。
- C) 在**20-25**摄氏度时
- D) 给出的数值以正常至有利的环境条件为前提 (例如无扰动、无大雾、无烟雾、无直接的阳光照射)。强烈的温度波动之后可能导致精度偏差。
- E) 仅出现非导电性污染, 不过有时会因凝结而暂时具备导电性。
- F) 仅在与旋转平台组合时使用

型号铭牌上的序列号(4)是测量仪唯一的识别码。

安装

装入/更换电池

建议使用碱性电池运行测量仪。

按下止动件(2)以打开电池盒盖(3), 然后取下电池盒盖。装入电池。

根据电池盒内部的图示, 注意电极是否正确。

如果状态指示灯(15)闪烁, 则必须更换电池。

务必同时更换所有的电池。请使用同一制造厂商所生产的相同容量电池。

- ▶ **长时间不用时, 请将电池从测量仪中取出。** 在长时间存放于测量仪中的情况下, 蓄电池可能会腐蚀以及自行放电。

使用旋转平台进行操作 (参见插图A)

借助旋转平台(12)可将测量仪围绕始终可见的中央下对点进行360°的转动。这样就能精准设置激光线, 而无需改变测量仪的位置。

将测量仪放到旋转平台(12)上, 使旋转平台的固定凹槽(13)对准测量仪底面上的相应固定凹槽(6)之间。顺时针旋转测量仪, 以便将其锁止在旋转平台上。

使用高度调节螺栓(10)拧出旋转平台(12)的支脚。

借助水准仪(8)大致对齐旋转平台。

如果测量仪是安装在旋转平台(12)上的, 可以用微调螺栓(11)将垂直激光线与参考点精确对准。

工作

投入使用

- ▶ **不可以让湿气渗入仪器中, 也不可以让阳光直接照射在仪器上。**
 - ▶ **请勿在极端温度或温度波动较大的情况下使用测量仪。** 比如请勿将测量仪长时间放在汽车内。温度波动较大的情况下, 先让测量仪的温度稳定下来, 在继续加工前应先进行精度检查(参见“测量仪精度检查”, 页 14)。
- 如果仪器暴露在极端的气候下或温差相当大的环境中, 会影响测量仪的测量准确度。

- ▶ **避免让测量仪发生剧烈碰撞或将其跌落。** 测量仪受到强烈的外部作用之后, 在重新使用之前务必进行精度检查(参见“测量仪精度检查”, 页 14)。

- ▶ **运输时, 请关闭测量仪。** 关机后摆动零件会被锁定, 否则摆动零件可能因为强烈的震动而受损。

接通/关闭

如要**接通**测量仪, 请将电源开关(7)推到位置“On” (操作时使用摆动止动件) 或推到位置“On” (操作时使用自动找平功能)。状态指示灯(15)亮起。启动后, 测量仪立即从当前发射口(1)射出一条水平激光线。

- ▶ **不得将激光束对准人或动物, 也请勿直视激光束, 即使和激光束相距甚远也不可以做上述动作。**

如要**关闭**测量仪, 请将电源开关(7)推到位置“Off”。状态指示灯(15)熄灭。关闭状态下, 摆动单元会被锁止。

- ▶ **测量仪接通后应有人看管, 使用后应关闭。** 激光可能会让旁人炫目。

超出所允许的最高工作温度**45 °C**时, 测量仪就会关闭以保护激光二极管。待测量仪冷却后便能够再度操作, 此时您又可以再度开动仪器了。

停用自动关机功能

测量仪会在**30**分钟后自动关闭。

如需停用自动断开装置, 请在测量仪接通状态时长按**3**秒垂直模式按键(16)或水平模式按键(17)。若停用了自动关机功能, 激光束会在**3**秒后短暂闪烁。

如需激活自动关机功能, 请关闭测量仪然后再次接通 (无需按压按键)。

运行模式

本测量仪有若干种不同的运行模式, 可以随时进行转换。水平和垂直模式可以彼此独立地接通和关闭。测量仪在开机后处于水平模式中。

在所有运行模式中均可选择使用自动找平功能或使用摆动止动件。

水平模式 (参见插图B)

测量仪在水平模式中向前发出一根水平激光线。

如要接通或关闭水平激光线, 请按压水平模式按键(17)。

垂直模式和下对点 (参见插图C-D)

本测量仪有两种不同的垂直运行模式:

- 向前发出垂直激光线,
- 向前和向右侧发出垂直激光线。

在垂直模式中, 始终会向下投射一个下对点。

如要接通或关闭垂直模式以及切换垂直模式, 请多次按压垂直模式按键(16), 直至所需的运行模式。

自动找平功能

使用自动找平功能进行测量

将测量仪放到一个水平的、稳固的地板上或将其固定到旋转平台(12)上。

对于带自动找平功能的操作，请将起停开关(7)推到位置“On”。

在 $\pm 3^\circ$ 的自找平范围内自动校平。只要激光线不再移动则表示测量仪已经完成找平。

如果无法自动找平，比如因为测量仪的支承面与水平偏差超过 3° ，激光束会以快节拍闪烁。

发生上述情况时，必须先水平放置测量仪，然后等待其自动找平。一旦测量仪处于 $\pm 3^\circ$ 度的自调平范围内，激光束会长亮。

运行中若出现抖动或位置改变，测量仪会自动再次找平。在找平之后得利用参考点检查激光的位置，以避免因为仪器的位置改变而造成误差。

操作时使用摆动止动件

对于带摆动止动件的操作，请将电源开关(7)推到位置“On”。摆动止动件指示灯(14)亮起红灯，激光线一直以慢节拍闪烁。

使用摆动止动件操作时，自动找平功能关闭。您可以把测量仪握在手上或者放在倾斜的底垫上操作。此时激光束不再找平并且不再强制性地彼此垂直。

测量仪精度检查

影响精度的因素

操作环境的温度是最大的影响因素。尤其是由地面往上延伸的渐进式温度差异可能会转移激光束。

由于接近地面的温度积层最大，最好把测量仪安装到三脚架上，然后放到工作区域的中央。

除了外部影响，对设备特殊的影响（例如掉落或强烈撞击）也会导致出现偏差。因此，每次工作前都要检查校准准确性。

首先检测水平激光线的高度和找平准确性，然后检测垂直激光线的找平准确性。

如果在检查时发现测量仪的偏差超过最大极限，则将其交给Bosch客户服务处进行修理。

检测水平激光线的高度准确性

针对这项检查，您必须找一段无障碍物的5米长线段，而且该测量线段必须介于两面墙A和B之间。

- 将测量仪靠近墙壁A安装在旋转平台(12)或三脚架(24)上，或者将它放置在稳固、平坦的底垫上。在带自动找平功能的模式中接通测量仪。接通向前发射垂直激光线的水平模式和垂直模式。

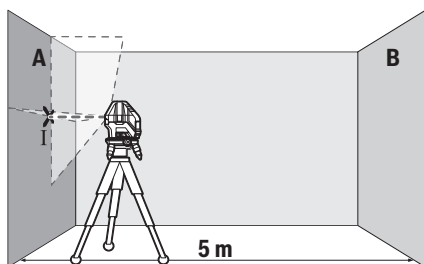

- 把激光束对准比较靠近的墙A并让测量仪找平。找到激光束在墙面上交叉的那一点（点I），并标记该点的中心位置。

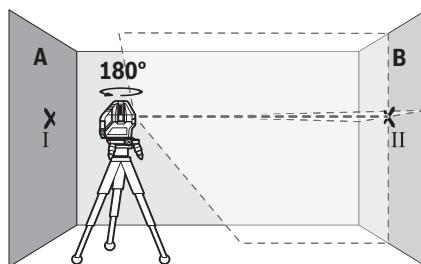

- 将测量仪旋转 180° ，找平，然后在对面的墙B上标记激光束的交叉点（点II）。
- 靠近墙B放下测量仪，不要旋转，接通，找平。

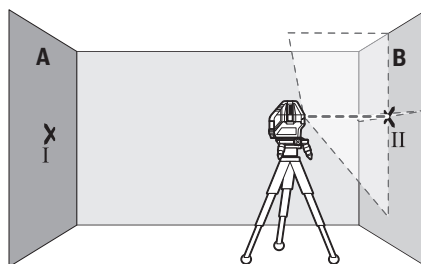

- 调整测量的高度（借助三脚架，必要时通过垫板），使激光线的交叉点正好与墙B上之前标记的点II重合。

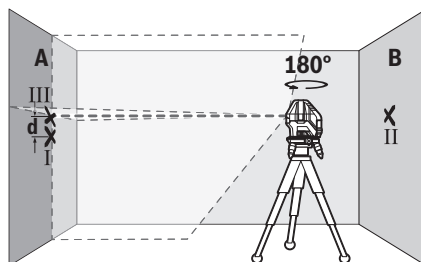

- 将测量仪旋转 180° ，不要改变高度。将测量仪对准墙A，使垂直激光线穿过标记的点I。让测量仪找平并标记激光线在墙A上的交叉点（点III）。
- 墙A上标记的点I和点III之间的差值d就是测量仪的实际高度差。

在 $2 \times 5 \text{米} = 10 \text{米}$ 的测量距离内允许的最大偏差为： $10 \text{米} \times \pm 0.2 \text{毫米/米} = \pm 2 \text{毫米}$ 。就是说，点I和点III之间的差值d最大允许为2毫米。

检测水平激光线的找平准确性

针对这项检测，必须找一块约 $5 \times 5 \text{米}$ 的空闲区域。

- 将测量仪安装在墙面A和B之间中间的旋转平台(12)或三脚架(24)上，或者将测量仪放置在稳固、平坦的底垫上。在带自动找平功能的模式中接通测量仪。接通水平模式，使测量仪调平。

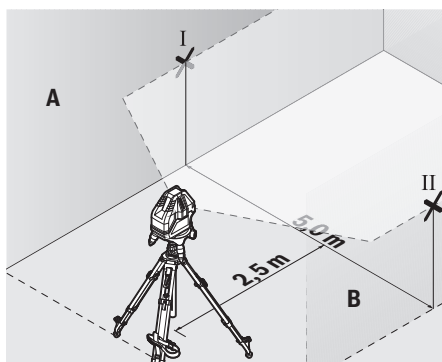

- 在距测量仪2.5米的两墙上标记激光线的中心（在墙A上标记点I，在墙B上标记点II）。

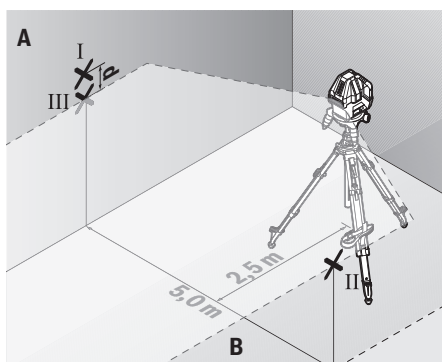

- 将测量仪旋转180°放到5米的距离外，让其自动找平。
- 调整测量仪的高度（借助三脚架，必要时通过垫板），使激光线的中心正好与墙B上之前标记的点II重合。
- 在墙A上将激光线的中心标记为点III（垂直于点I上方或下方）。
- 墙A上标记的点I和点III之间的差值d就是测量仪与水平面之间的实际偏差。

在 2×5 米 = 10米的测量距离内允许的最大偏差为： $10 \text{米} \times \pm 0.2 \text{毫米/米} = \pm 2 \text{毫米}$ 。就是说，点I和点III之间的差值d最大允许为2毫米。

检查垂直激光线的找平准确性

检查时需要一个门孔，（在稳固基底上）检查时门各侧至少有2.5米的位置。

- 将测量仪放置在距离门孔2.5米远的稳固、平坦的基底上（而不是在旋转平台(12)上）。在带自动找平功能的模式中接通测量仪。接通向前发射垂直激光线的垂直模式，并将激光线对准门孔。让测量仪调平。

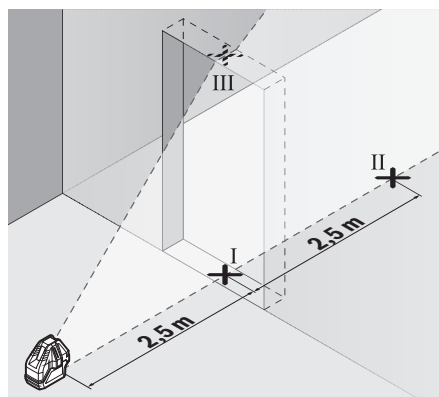

- 在门孔底（点I）、距门孔侧面5米（点II）和距门孔上边缘5米（点III）处分别标记垂直激光线的中心。

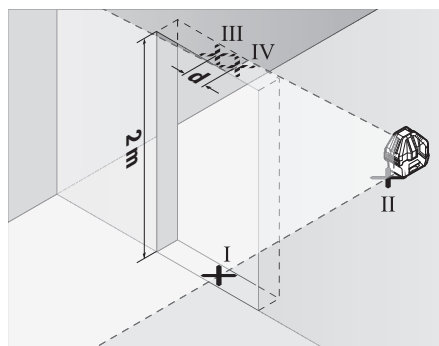

- 将测量仪旋转180°，然后将其放到门口的另一侧，正好位于点II的下方。让测量仪找平，以校准垂直激光线，使激光线的中心正好贯穿点I和点II。
- 将门孔上边缘的激光线中心标记为点IV。
- 点III和IV之间的差值d就是测量仪在垂直方向的实际偏差。
- 测量门孔的高度。

请按如下步骤计算所允许的最大偏差：

两倍的门孔高度 $\times 0.2$ 毫米/米

例如：门孔高度为2米，则允许的最大偏差

$2 \times 2 \text{米} \times \pm 0.2 \text{毫米/米} = \pm 0.8 \text{毫米}$ 。就是说，点III和IV之间最多相距0.8毫米。

工作提示

- ▶ 仅使用激光点或激光线中心来标记。激光点的大小或激光线段的宽度会随著距离而改变。

使用激光靶工作

在条件不佳和距离较远时，激光靶(22)可以改善激光束的可见性。

激光靶(22)的反光面可以改善激光线的可见性，通过透明面可以在激光靶的背面看到激光线。

使用三脚架（附件）进行操作（参见插图F）

三脚架提供稳定且高度可调的测量底座。如需将测量仪安装到三脚架上，请将测量仪放到旋转平台(12)上。

安装到5/8英寸三脚架上：利用5/8英寸三脚架接头(9)将旋转平台装到5/8英寸三脚架(24)或市售组合式三脚架的螺纹上。使用三脚架的固定螺栓拧紧旋转平台。

安装到1/4英寸三脚架上（参见插图F）：将三脚架适配器(18)（附件）拧入旋转平台的5/8英寸三脚架接头(9)。利用1/4英寸三脚架接头，将三脚架适配器装到1/4英寸三脚架(19)或市售摄影三脚架的螺纹上。使用三脚架的固定螺栓拧紧三脚架适配器。在开动测量仪之前，先大略地调整好三脚架的位置。

激光辨识镜（附件）

激光辨识镜会过滤周围环境的光线。因此激光束会显得更亮。

- ▶ **激光视镜（附件）不得用作护目镜。** 激光视镜用于更好地识别激光束；然而对激光束并没有防护作用。
- ▶ **激光视镜（附件）不得用作太阳镜或在道路交通中使用。** 激光视镜并不能完全防护紫外线，还会干扰对色彩的感知。

工作范例（参见插图B-E）

有关测量仪的使用范例请参考说插图说明。

维修和服务

维护和清洁

测量仪器必须随时保持清洁。

不可以把仪器放入水或其它的液体中。

使用潮湿，柔软的布擦除仪器上的污垢。切勿使用任何清洁剂或溶剂。

务必定期清洁激光出口，清洁时不可以在出口残留绒毛。

产品中有害物质的名称及含量

部件名称	有害物质					
	铅 (Pb)	汞 (Hg)	镉 (Cd)	六价铬 (Cr ⁶⁺)	多溴联苯 (PBB)	多溴二苯醚 (PBDE)
外壳的金属部分	X	O	O	O	O	O
外壳的非金属部分（包括玻璃）	O	O	O	O	O	O
组合印刷电路板	X	O	O	O	O	O
附件 ^{A)}	X	O	O	O	O	O
碱性锰电池系统	O	O	O	O	O	O
充电电池系统 ^{B)}	X	O	O	O	O	O
键盘	O	O	O	O	O	O
显示器 ^{C)}	O	O	O	O	O	O
激光模块 ^{D)}	X	O	O	O	O	O

存储和搬运测量仪时，一定要将其放在保护袋(23)中。

需要修理时，请将测量仪装入保护袋(23)邮寄。

客户服务和应用咨询

本公司客户服务处负责回答有关本公司产品的修理、维护和备件的问题。备件的展开图纸和信息也可查看：www.bosch-pt.com

博世应用咨询团队乐于就我们的产品及其附件问题提供帮助。

询问和订购备件时，务必提供机器铭牌上标示的10位数物品代码。

中国大陆

博世电动工具（中国）有限公司

中国 浙江省 杭州市

滨江区 滨康路567号

102/1F 服务中心

邮政编码：310052

电话：(0571)8887 5566 / 5588

传真：(0571)8887 6688 x 5566# / 5588#

电邮：bsc.hz@cn.bosch.com

www.bosch-pt.com.cn

制造商地址：

Robert Bosch Power Tools GmbH

罗伯特·博世电动工具有限公司

70538 Stuttgart / GERMANY

70538 斯图加特 / 德国

其他服务地址请见：

www.bosch-pt.com/serviceaddresses

废弃处理

必须以符合环保要求的方式回收再利用测量仪、附件和包装材料。



请勿将测量仪和电池/蓄电池扔到生活垃圾里！

部件名稱	有害物質					
	鉛 (Pb)	汞 (Hg)	鎘 (Cd)	六價鉻 (Cr ⁶⁺)	多溴聯苯 (PBB)	多溴二苯醚 (PBDE)
內部連接電纜	○	○	○	○	○	○

- A) 適用於採用附件的產品
 B) 適用於採用充電電池電供的產品
 C) 適用於採用顯示器的產品
 D) 適用於採用激光模塊的產品

本表是按照SJ/T 11364的規定編制

O: 表示該有害物質在該部件所有物質材料中的含量均在GB/T 26572規定的限量要求以下。

X: 表示該有害物質至少在該部件的某一物質材料中的含量超出GB/T 26572規定的限量要求，且目前業界沒有成熟的替代方案，符合歐盟RoHS指令環保要求。

產品環保使用期限內的使用條件參見產品說明書。

繁體中文

安全注意事項



為確保能夠安全地使用本測量工具，您必須完整詳讀本說明書並確實遵照其內容。若未依照現有之說明內容使用測量工具，測量工具內部所設置的防護措施可能無法發揮應有功效。謹慎對待測量

工具上的警告標示，絕對不可讓它模糊不清而無法辨識。請妥善保存說明書，將測量工具轉交給他人時應一併附上本說明書。

- ▶ **小心** - 若是使用非此處指明的操作設備或校正設備，或是未遵照說明的操作方式，可能使您暴露於危險的雷射光照射環境之下。
- ▶ 本測量工具出貨時皆有附掛雷射警示牌（即測量工具詳解圖中的標示處）。
- ▶ 雷射警示牌上的內容若不是以貴國語言書寫，則請於第一次使用前將隨附的當地語言說明貼紙貼覆於其上。



請勿將雷射光束對準人員或動物，您本人亦不可直視雷射光束或使雷射光束反射。因為這樣做可能會對他人眼睛產生眩光，進而引發意外事故或使眼睛受到傷害。

- ▶ 萬一雷射光不小心掃向眼睛，應立刻閉上眼睛並立刻將頭轉離光束範圍。
- ▶ 請勿對本雷射裝備進行任何改造。
- ▶ 請勿將雷射眼鏡當作護目鏡（配件）使用。雷射眼鏡是用來讓您看清楚雷射光束；但它對於雷射光照射並沒有保護作用。
- ▶ 請勿將雷射眼鏡當作護目鏡（配件）使用，或在道路上行進間使用。雷射眼鏡無法完全阻隔紫外線，而且還會降低您對於色差的感知能力。
- ▶ 本測量工具僅可交由合格的專業技師以原廠替換零件進行維修。如此才能夠確保本測量工具的安全性能。

- ▶ **不可放任兒童在無人監督之下使用本雷射測量工具。** 他們可能會不小心對他人或自己的眼睛產生眩光。
- ▶ **請不要在存有易燃液體、氣體或粉塵等易爆環境下操作本測量工具。** 測量工具內部產生的火花會點燃粉塵或氣體。



測量工具與磁性配件不得接近植入裝置以及諸如心律調節器或胰島素幫浦等其他醫療器材。測量工具和配件中含有磁鐵，形成的磁場可能干擾植入裝置和醫療器材運作。

- ▶ **請讓測量工具與磁性配件遠離磁性資料儲存裝置和易受磁場干擾的高靈敏器材。** 測量工具與配件內的磁鐵，形成的磁場可能造成無法挽救的資料遺失。

產品和功率描述

請留意操作說明書中最前面的圖示。

依規定使用機器

此測量工具的設計適合用來確認及檢查水平線、垂直線和鉛垂點。

本測量工具適合在室內使用。

插圖上的機件

機件的編號和儀器詳解圖上的編號一致。

- (1) 雷射光束射出口
- (2) 電池盒蓋鎖扣
- (3) 電池盒蓋
- (4) 序號
- (5) 雷射警示牌
- (6) 測量工具的固定用凹槽
- (7) 起停開關
- (8) 轉檯水平儀
- (9) 轉檯的 5/8" 三腳架固定座
- (10) 轉檯高度調整螺柱
- (11) 轉檯微調螺柱
- (12) 轉檯
- (13) 轉檯的固定用凹槽
- (14) 擺動鎖指示器
- (15) 狀態指示器
- (16) 垂直操作鍵

- (17) 水平模式按鈕
- (18) 三腳架轉接器^{a)}
- (19) 1/4" 三腳架^{a)}
- (20) 雷射辨識鏡^{a)}
- (21) 磁鐵^{a)}
- (22) 雷射標靶^{a)}
- (23) 保護套袋
- (24) 5/8" 三腳架^{a)}

a) 圖表或說明上提到的配件，並不包含在基本的供貨範圍中。本公司的配件清單中有完整的配件供應項目。

技術性數據

雷射墨線儀	GLL 3-15 X
產品機號	3 601 K63 M..
工作範圍 ^{A)}	
- 雷射標線	15 m
- 鉛垂點	5 m
雷射標線的調平精準度 ^{B)C)D)}	±0.2 mm/m
自動調平範圍標準值	±3°
調平耗時標準值	< 4 秒
操作溫度	-10 °C ... +45 °C
儲藏溫度	-20 °C ... +70 °C
最高適用海拔	2000 m
空氣相對濕度最大值	90 %
依照 IEC 61010-1, 污染等級為	2 ^{E)}
雷射等級	2
雷射種類	< 1 mW, 630-650 nm
C ₆	1
光束發散角	
- 雷射標線	1.5 mrad
- 鉛垂點	1.5 mrad
三腳架固定座 ^{F)}	5/8"
電池	4 × 1.5 VLR6 (AA)
連續工作時間約略值 ^{C)}	
- 使用 1 條雷射標線	24 小時
- 使用 2 道雷射標線	14 小時
- 使用 3 道雷射標線	10 小時
重量符合	0.54 kg
EPTA-Procedure 01:2014	
尺寸 (長 × 寬 × 高)	
- 不含轉檯	122 × 83 × 129 mm
- 含轉檯	直徑 151 × 203 mm

雷射墨線儀 GLL 3-15 X

防護等級 (不含電池盒) IP 54 (防塵防潑濺)

- A) 工作範圍在不利的環境條件下 (例如陽光直射), 工作範圍將縮小。
 - B) 出廠時的設定
 - C) 溫度為 20-25 °C
 - D) 此處提供的是在一般至有利環境條件下可達到的數值 (比如無震動、無霧氣、無煙霧、無陽光直射)。歷經劇烈溫度起伏之後, 精準度可能會發生偏差。
 - E) 只產生非傳導性污染, 但應預期偶爾因水氣凝結而導致暫時性導電。
 - F) 僅可搭配轉檯一同使用
- 從產品銘牌的序號 (4) 即可確定您的測量工具機型。

安裝

裝入/更換電池

建議使用鹼錳電池來驅動本測量工具。

若要打開電池盒蓋 (3), 請按壓鎖扣 (2) 並取下電池盒蓋。裝入電池。

此時請您注意是否有依照電池盒內側上的電極標示正確放入。

如果狀態指示器 (15) 閃爍, 則須更換電池。

務必同時更換所有的電池。請使用同一製造廠商, 容量相同的電池。

- ▶ **長時間不使用時, 請將測量工具裡的電池取出。**
電池可能因長時間存放於測量工具中不使用而自行放電。

作業時使用轉檯 (請參考圖 A)

本測量工具可在轉檯 (12) 的輔助之下, 沿著一個持續可見的中央鉛垂點 360° 旋轉。透過這個方法, 不需移動測量工具的位置, 即可精準標示雷射標線。

將測量工具安裝到轉檯 (12) 上, 使轉檯的固定用凹槽 (13) 與測量工具底部相應的固定用凹槽 (6) 之間吻合。沿順時針方向旋轉測量工具, 將之鎖緊到轉檯上。

利用高度調整螺栓 (10), 將轉檯 (12) 腳柱旋出。

利用水平儀 (8) 將轉檯大致校準。

將測量工具安裝至轉檯 (12) 上時, 利用微調螺栓 (11) 即可精準地將垂直雷射標線校正至基準點上。



操作

操作機器

- ▶ **不可以讓濕氣滲入儀器中, 也不可以讓陽光直接照射在儀器上。**
 - ▶ **勿讓測量工具暴露於極端溫度或溫度劇烈變化的環境。**例如請勿將它長時間放在車內。歷經較大溫度起伏時, 請先讓測量工具回溫, 而且一定要檢查精準度, 確認後才能繼續進行測量 (參見「測量工具精準度檢查」, 頁 19)。
- 如果儀器曝露在極端溫度下或溫差較大的環境中, 會影響儀器的測量準確度。

- ▶ **測量工具須避免猛力碰撞或翻倒。**測量工具遭受外力衝擊後，一律必須先檢查其精準度，確認後才能繼續使用(參見「測量工具精準度檢查」，頁 19)。
- ▶ **若要搬運測量工具時，請先將它關閉。**關機後擺動零件應要被鎖定，否則擺動零件可能因為強烈的震動而受損。

啟動/關閉

若要**啟動**測量工具，請將起停開關 (7) 推至「 On」(適用於使用擺動鎖進行測量)或「 On」(適用於自動調平功能開啟之測量作業)。狀態指示器 (15) 亮起。啟動後，測量工具立即從前方射出出口 (1) 射出一道水平雷射標線。

- ▶ **雷射光束不可以對準人或動物，操作人本身也不要直視光束，即使和光束相距甚遠也不可以做上述動作。**

若要**關閉**測量工具，請將起停開關 (7) 推至「Off」位置。狀態指示器 (15) 變暗。關閉時，擺動零件即遭鎖定。

- ▶ **不可放任啟動的測量工具無人看管，使用完畢後請關閉測量工具電源。**雷射可能會對旁人的眼睛產生眩光。

當操作溫度已超出最高允許值 45°C 時，將自動關機以保護雷射二極體。待測量工具冷卻後又能再度操作時，您即可重新開機。

停用儀器的自動關機功能

測量工具會在連續工作 30 分鐘後自動關機。

若要停用自動關機功能，請於啟動測量工具時按住垂直模式按鈕 (16) 或水平模式按鈕 (17) 不放，維持 3 秒鐘。自動關機功能成功停用時，雷射光束將於 3 秒鐘後短暫閃爍。

若要啟用此一自動關機功能，請將測量工具關閉後再重新啟動即可(不按任何按鈕)。

操作模式

測量工具提供多種操作模式，供您隨時進行切換。水平模式與垂直模式可各自獨立開啟或關閉。啟動後，測量工具隨即進入水平模式。

所有操作模式皆可選擇是否要使用自動調平功能或擺動鎖。

水平模式 (請參考圖 B)

測量工具處於水平模式下時，會向前發射出一道水平雷射標線。

若要關閉或開啟此道水平雷射標線，請按水平模式按鈕 (17)。

垂直模式和鉛垂點 (請參考圖 C-D)

本測量工具擁有兩種垂直操作模式：

- 向前發射的垂直雷射標線、
- 向前發射以及向右發射的垂直雷射標線。

此外，在垂直模式下一律會有一個向下投射的鉛垂點。

若要開啟或關閉垂直模式或者想要切換至其他種類的垂直模式，請重複按壓垂直模式按鈕 (16)，直到工具進入所需操作模式。

自動調平功能

自動調平功能開啟之測量作業

請將本測量工具放置在一個穩固的水平平面上，或將它固定在轉檯 (12) 上。

針對使用自動調平功能的作業，請您將起停開關 (7) 推至「 On」位置。

自動調平功能會在相差 $\pm 3^{\circ}$ 的自動調平範圍內自動調整。雷射標線靜止不動時，表示調平結束。

若無法使用自動調平功能，例如一旦測量工具的所在平面與水平面之間相差達 3° 以上時，雷射光束將快速閃爍。

發生上述情況時，請將本測量工具架設在水平平面上，然後等待其自動調平。測量工具一進入 $\pm 3^{\circ}$ 的自動調平範圍時，雷射光束隨即再度持續亮起。

測量工具在運轉期間若有振動或移位，將重新進行調平。在完作調平之後應利用參考點檢查雷射光束的位置，以免因為儀器位置改變而造成測量錯誤。

使用擺動鎖進行測量

若要使用擺動鎖進行測量，請您將起停開關 (7) 推至「 On」。擺動鎖指示器 (14) 將亮紅燈，且雷射標線會以緩慢節奏持續閃爍。

使用擺動鎖進行測量時，自動調平功能將關閉。您可以把測量工具拿在手上或是將它放置到合適的基座上操作。雷射光束不再進行調平，也不再強制性地彼此垂直。

測量工具精準度檢查

影響精度的因素

操作環境的溫度是最大的影響因素。尤其是由地面往上延伸的漸進式溫度差異可能會使雷射光束改變方向。

靠近地面的位置其溫度分層變化最大，因此您應儘量將測量工具安裝在三腳架上，然後將它架設在作業區的中央。

除了外在因素，發生偏差的原因亦可能來自機器本身(例如機器曾翻倒或受到猛力撞擊)。因此，每次開始工作之前，請您先進行調平精準度檢查。

一律先檢查水平雷射標線的高度精準度及調平精準度，然後再檢查垂直雷射標線的調平精準度。

如果檢查時發現測量工具的偏差超過最大極限。必須把儀器交給 **Bosch** 顧客服務處修理。

請檢查水平線的高度精準度

針對這項檢查，您必須在兩面牆 A 和牆 B 之間找出一段無障礙物、長度 5 m 的測量距離。

- 請將測量工具先安裝在轉檯 (12) 或三腳架 (24) 上後，再架設到 A 牆附近的位置，或將測量工具放置在穩固的平坦基座上。請將測量工具開啟為使用自動調平功能。開啟水平模式或垂直模式，會有一道向前發射的雷射標線。

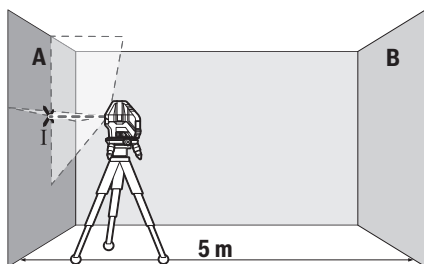

- 把雷射光束對準比較靠近的 A 牆並讓測量儀進行調平。標示出雷射標線在牆上之交叉點的中心位置 (I 點)。

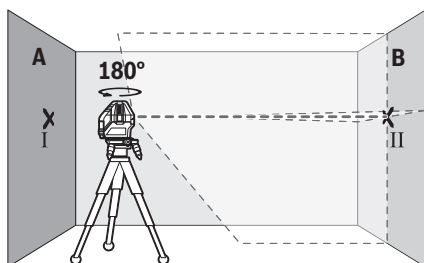

- 將測量工具旋轉 180°，讓它進行調平，然後在對面的 B 牆上標出雷射標線的交叉點 (II 點)。
- 將測量工具 (不用旋轉) 移至靠近 B 牆附近，然後啟動電源，讓它進行調平。

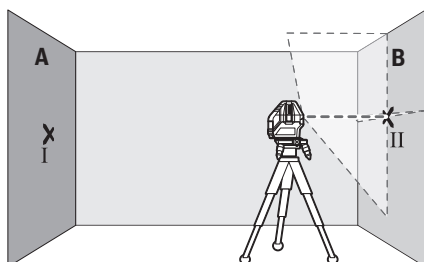

- 調整測量工具的高度 (利用三腳架或者必要時可再墊高)，讓雷射標線的交叉點正好對準先前在 B 牆上標出的 II 點。

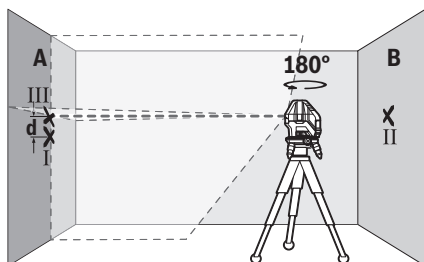

- 將測量工具旋轉 180°，但不用再改變其高度。這次要讓它對準那條通過 A 牆 I 點的垂直線。讓測

量工具進行調平，接著再到 A 牆上標出雷射標線的交叉點 (III 點)。

- A 牆上標出的 I 與 III 兩點相差的高度 d 即是測量工具的實際高度偏差。

測量距離為 $2 \times 5 \text{ m} = 10 \text{ m}$ 時的最大容許偏差是：
 $10 \text{ m} \times \pm 0.2 \text{ mm/m} = \pm 2 \text{ mm}$ 。因此，I 和 III 兩點之間相差的距離 d 最多只能有 2 mm。

請檢查水平線的調平精準度

針對這項檢查，您必須找一塊約 $5 \times 5 \text{ m}$ 的無障礙物空間。

- 請將測量工具先安裝在轉檯 (12) 或三腳架 (24) 後，再架設到 A 牆與 B 牆的中間點，或將測量工具放置於穩固的平坦基座上。請將測量工具開啟為使用自動調平功能。啟動水平模式，然後讓測量工具進行調平。

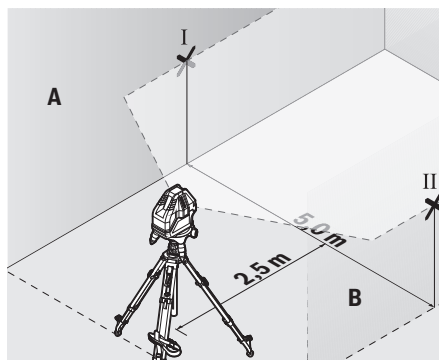

- 請在與測量工具相隔 2.5 m 的兩邊牆面上標出雷射標線的中心點 (A 牆上為 I 點，B 牆上為 II 點)。

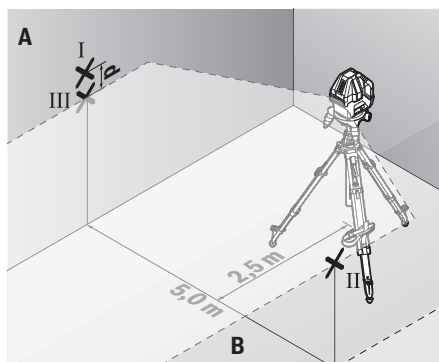

- 將測量工具旋轉 180° 後架設在相隔 5 m 距離的位置上，然後讓它進行調平。
- 調整測量工具的高度 (利用三腳架或者必要時可再墊高)，讓雷射標線的中心點正好對準先前在 B 牆上標出的 II 點。
- 請在 A 牆上標出雷射標線的中心點，此即為 III 點 (與 I 點呈一垂直線，可能位於 I 點之上或之下)。

- A 牆上標出的 I 與 III 兩點相差的高度 **d** 即是測量工具的實際水平高度偏差。

測量距離為 $2 \times 5 \text{ m} = 10 \text{ m}$ 時的最大容許偏差是： $10 \text{ m} \times \pm 0.2 \text{ mm/m} = \pm 2 \text{ mm}$ 。因此，I 和 III 兩點之間相差的距離 **d** 最多只能有 2 mm。

檢查垂直線的調平精準度

為進行此項檢查，您需要找出一處地面平坦穩固的門口，門的兩邊都至少有 2.5 m 的深度。

- 請將測量工具放置於穩固的平坦地面（非轉檯 (12) 或三腳架）上，與門口相距 2.5 公尺。請將測量工具開啟為使用自動調平功能。請啟動會向前發射一條垂直雷射標線的垂直模式，然後將這條雷射標線對準門口。讓測量工具進行調平。

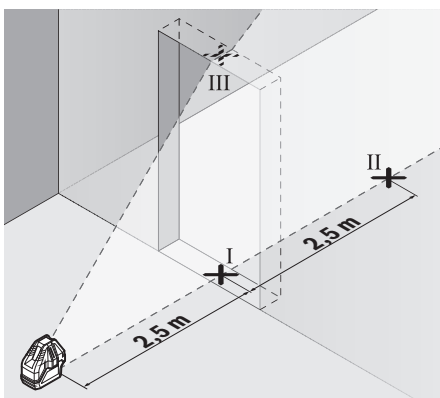

- 請在門口地面上 (I 點)、在門口另一邊與目前位置相距 5 m 的位置上 (II 點) 以及門口上緣處 (III 點)，標出垂直雷射標線的中心點。

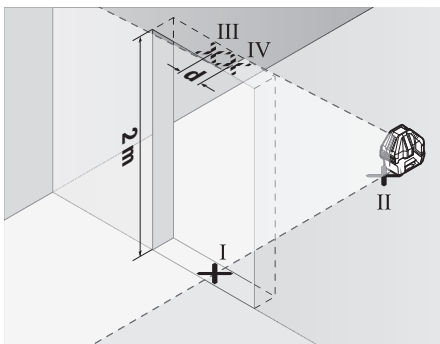

- 將測量工具旋轉 180°，並將其移至門口另一邊，正好放在 II 點後。讓測量工具進行調平，並調整垂直雷射標線的位置，讓它的中心點剛好同時通過 I 點及 II 點。
- 在門口上緣處標出雷射標線的中心點，此即為 IV 點。
- III 與 IV 兩點之間相差的距離 **d** 即是測量工具的實際垂直偏差。

- 測量門口的高度。

最大容許偏差的計算方式如下：

兩倍的門口高度 $\times 0.2 \text{ mm/m}$

舉例來說：如果門口高度為 2 m，則最大容許偏差為

$2 \times 2 \text{ m} \times \pm 0.2 \text{ mm/m} = \pm 0.8 \text{ mm}$ 。因此，III 及 IV 兩點最多可相差 0.8 mm。

作業注意事項

- ▶ 一律只能標示雷射點/雷射標線的中心位置。雷射點的大小或雷射線段的寬度會隨著距離而改變。

使用雷射靶進行測量

雷射靶靶 (22) 可增強雷射光束在不利條件下以及距離較長時的能見度。

雷射靶靶 (22) 的平面具反射作用，它可增強雷射標線的能見度，另一半則是可透光，讓您從雷射靶背面也能看清楚雷射標線。

使用測量三腳架 (配件) 進行測量 (請參考圖 F)

三腳架可為您提供一個可調整高度的穩固測量基座。若要在三腳架上安裝測量工具，請將測量工具安裝到轉檯 (12) 上。

安裝至 5/8" 三腳架：請將轉檯透過其 5/8" 三腳架固定座 (9) 安裝至三腳架 5/8" (24) 或一般市售土木用三腳架的螺紋孔上。利用三腳架的止付螺絲，將轉檯旋緊固定。

安裝於 1/4" 三腳架上 (請參考圖 F)：將三腳架轉接器 (18) (配件) 旋緊至轉檯的 5/8" 三腳架固定座 (9)。請利用 1/4" 三腳架固定座將三腳架轉接器安裝到 1/4" 三腳架 (19) 或一般市售相機三腳架的螺紋孔上。利用三腳架的止付螺絲，將三腳架轉接器旋緊固定。

在啟動測量工具之前，先大略地調整好三腳架的位置。

雷射視鏡 (配件)

雷射視鏡可過濾掉周圍環境的光線。因此，您的眼睛看到雷射光時會覺得較亮。

- ▶ 請勿將雷射眼鏡當作護目鏡 (配件) 使用。雷射眼鏡是用來讓您看清楚雷射光束；但它對於雷射光照射並沒有保護作用。
- ▶ 請勿將雷射眼鏡當作護目鏡 (配件) 使用，或在道路上行進間使用。雷射眼鏡無法完全阻隔紫外線，而且還會降低您對於色差的感知能力。

操作範例 (請參閱圖 B-E)

有關測量工具的使用範例請參考說插圖說明。

維修和服務

維修和清潔

測量儀器必須隨時保持清潔。

不可以把儀器放入水或其它的液體中。

使用柔軟濕布擦除儀器上的污垢。切勿使用清潔劑或溶液。

務必定期清潔雷射出口，清潔時射出口不可殘留毛絮。

儲放和搬運測量工具時，一定要將它放置在保護套袋 (23) 內。

如需送修，請將測量工具放入保護套袋 (23) 內後，再轉交給相關單位。

顧客服務處和顧客諮詢中心

本公司顧客服務處負責回答有關本公司產品的維修、維護和備用零件的問題。以下的網頁中有分解圖和備用零件相關資料：www.bosch-pt.com

如果對本公司產品及其配件有任何疑問，博世應用諮詢小組很樂意為您提供協助。

當您需要諮詢或訂購備用零件時，請務必提供本產品型號銘牌上 10 位數的產品機號。

台灣

台灣羅伯特博世股份有限公司

建國北路一段90號6樓

台北市10491

電話: (02) 7734 2588

傳真: (02) 2516 1176

www.bosch-pt.com.tw

製造商地址:

Robert Bosch Power Tools GmbH

羅伯特·博世電動工具有限公司

70538 Stuttgart / GERMANY

70538 斯圖加特/德國

以下更多客戶服務處地址：

www.bosch-pt.com/serviceaddresses

廢棄物處理

必須以符合環保要求的方式回收再利用損壞的儀器、配件和包裝材料。



不得將測量工具與電池當成一般垃圾丟棄！

한국어

안전 수칙



측정공구의 안전한 사용을 위해 모든 수칙들을 숙지하고 이에 유의하여 작업하시기 바랍니다. 측정공구를 해당 지침에 따라 사용하지 않으면, 측정공구에 내장되어 있는 안전장치에 안 좋은 영향을 미칠 수 있습니다. 측정공구의 경고판을 절대로 가려서는 안 됩니다. 안전 수칙을 잘 보관하고 공구 양도 시 측정공구와 함께 전달하십시오.

- ▶ 주의 - 여기에 제시된 조작 장치 또는 조정 장치 외의 용도로 사용하거나 다른 방식으로 작업을 진행하는 경우, 광선으로 인해 폭발될 위험이 있습니다.

- ▶ 본 측정공구는 레이저 경고 스티커가 함께 공급됩니다(그림에 측정공구의 주요 명칭 표시).
- ▶ 처음 사용하기 전에 함께 공급되는 한국어로 된 레이저 경고 스티커를 독문 경고판 위에 붙이십시오.



사람이나 동물에게 레이저 광선을 비추거나, 광선을 직접 또는 반사시켜 보지 마십시오. 이로 인해 눈이 부시게 만들어 사고를 유발하거나 눈에 손상을 입을 수 있습니다.

- ▶ 눈으로 레이저 광선을 쳐다본 경우, 의식적으로 눈을 감고 곧바로 고개를 돌려 광선을 피하십시오.
- ▶ 레이저 장치를 개조하지 마십시오.
- ▶ 레이저 보안경(엑세서리)을 일반 보안경으로 사용하지 마십시오. 레이저 보안경은 레이저 광선을 보다 잘 감지하지만, 그렇다고 해서 레이저 광선으로부터 보호해주는 것은 아닙니다.
- ▶ 레이저 보안경(엑세서리)을 선글라스 용도 또는 도로에서 사용하지 마십시오. 레이저 보안경은 자외선을 완벽하게 차단하지 못하며, 색상 분별력을 떨어뜨립니다.
- ▶ 측정공구의 수리는 해당 자격을 갖춘 전문 인력에게 맡기고, 수리 정비 시 순정 부품만 사용하십시오. 이 경우에만 측정공구의 안전성을 오래 유지할 수 있습니다.
- ▶ 어린이가 무감독 상태로 레이저 측정공구를 사용하는 일이 없도록 하십시오. 의도치 않게 타인 또는 자신의 눈이 부시게 할 수 있습니다.
- ▶ 가연성 유체나 가스 혹은 분진 등 폭발 위험이 있는 곳에서 측정공구를 사용하지 마십시오. 측정공구에 분진이나 증기를 접화하는 스파크가 생길 수 있습니다.



측정공구 및 자성 액세서리를 심장 박동 조절장치 또는 인슐린 펌프와 같은 삽입물 및 기타 의학 기기 근처로 가져오지 마십시오. 측정공구 및 액세서리의 자석으로 인해 자기장이 형성되어 삽입물 및 의학 기기의 기능에 장애를 일으킬 수 있습니다.

- ▶ 측정공구와 자성 액세서리를 자기 데이터 매체나 자력에 예민한 기기에서 멀리 두십시오. 측정공구 및 액세서리의 자석으로 인해 데이터가 손실되어 복구되지 않을 수 있습니다.

제품 및 성능 설명

사용 설명서 앞 부분에 제시된 그림을 확인하십시오.

규정에 따른 사용

본 측정공구는 수평 및 수직 라인과 수직점을 측정 및 점검하기 위한 용도로 사용됩니다.

측정공구는 실내용입니다.

제품의 주요 명칭

제품의 주요 명칭에 표기되어 있는 번호는 측정공구의 그림이 나와있는 면을 참고하십시오.

- (1) 레이저빔 발사구
- (2) 배터리 케이스 덮개 잠금쇠
- (3) 배터리 케이스 덮개
- (4) 일련 번호
- (5) 레이저 경고판
- (6) 측정공구의 고정 홈
- (7) 전원 스위치
- (8) 회전대 수준기
- (9) 회전대의 5/8" 삼각대 홀더
- (10) 회전대의 높이 조정 나사
- (11) 회전대의 미세 조정 나사
- (12) 회전대
- (13) 회전대의 고정 홈
- (14) 펜 들림 고정 표시기
- (15) 상태 표시기
- (16) 수평 모드 버튼
- (17) 수직 모드 버튼
- (18) 삼각대 어댑터^{a)}
- (19) 삼각대 1/4"^{na)}
- (20) 레이저용 안경^{a)}
- (21) 자석^{a)}
- (22) 레이저 표적판^{a)}
- (23) 안전 케이스
- (24) 삼각대 5/8"^{na)}

a) 도면이나 설명서에 나와있는 액세서리는 표준 공급부품에 속하지 않습니다. 전체 액세서리는 저희 액세서리 프로그램을 참고하십시오.

제품 사양

라인 레이저	GLL 3-15 X
품번	3 601 K63 M..
작업 범위 ^{a)}	
- 레이저 라인	15 m
- 수직점	5 m
레이저 라인 레벨링 정확도 ^{b) c) d)}	±0.2 mm/m
자동 보정 범위, 평균	±3°
자동 보정 시간, 평균	< 4 초
작동 온도	-10 °C ... +45 °C
보관 온도	-20 °C ... +70 °C
기준 높이를 초과한 최대 사용 높이	2000 m
상대 습도 최대	90 %
IEC 61010-1에 따른 오염도	2 ^{E)}

라인 레이저	GLL 3-15 X
레이저 등급	2
레이저 유형	< 1 mW, 630-650 nm
C ₆	1
편차	
- 레이저 라인	1.5 mrad
- 수직점	1.5 mrad
삼각대 홀더 ^{F)}	5/8"
배터리	4 × 1.5 V LIR6 (AA)
작동 시간, 약 ^{G)}	
- 1개 레이저 라인 사용 시	24 시간
- 2개 레이저 라인 사용 시	14 시간
- 3개 레이저 라인 사용 시	10 시간
EPTA-Procedure 01:2014에 따른 중량	0.54 kg
치수(길이 × 폭 × 높이)	
- 회전대 미장착	122 × 83 × 129 mm
- 회전대 장착	∅ 151 × 203 mm
보호 유형(배터리 케이스 제외)	IP 54 (먼지 및 분무수 침투 방지)

- A) 직사광선 등의 불리한 환경 조건에서는 작업 범위가 줄어들 수 있습니다.
- B) 공장 출고 시
- C) 20-25 °C일 경우
- D) 제시된 값은 일반적인 조건 및 (예를 들어 진동, 안개, 연기, 직사광선이 발생하지 않는) 좋은 조건이 전제됩니다. 온도 편차가 심하면 정확도에 차이가 있을 수 있습니다.
- E) 비전도성 오염만 발생하지만, 가끔씩 이슬이 맺히면 임시로 전도성이 생기기도 합니다.
- F) 회전대를 이용하여 작업하는 경우에만 제공 측정공구를 확실하게 구분할 수 있도록 타입 표시판에 일련 번호 (4)가 적혀 있습니다.

조립

배터리 삽입하기/교환하기

측정공구 작동에는 알칼리 망간 배터리를 사용할 것을 권장합니다.

배터리 케이스 덮개 (3)를 열기 위해 잠금쇠 (2) 위치까지 누른 뒤 배터리 케이스 덮개를 빼냅니다. 배터리를 끼웁니다.

이때 전극이 배터리 케이스 안쪽에 나와있는 것처럼 올바르게 끼워야 합니다.

상태 표시기 (15)가 깜박이면 배터리를 교체해야 합니다.

모든 배터리는 항상 동시에 교체하십시오. 한 제조사의 용량이 동일한 배터리로만 사용하십시오.

▶ **오랜 기간 사용하지 않을 경우 측정공구의 배터리를 빼두십시오.** 배터리를 측정공구에 오래 두면 부식되고 방전될 수 있습니다.

회전대를 이용한 작업(그림 A 참조)

회전대 (12) 를 이용하여 측정공구를 눈에 보이는 중앙 수직점 주위에서 360° 돌리십시오. 이렇게 하면 측정공구의 위치를 바꾸지 않고도 레이저 라인을 정확하게 조정할 수 있습니다.

측정공구를 회전대 (12) 에 설치할 때, 회전대의 고정 홈 (13) 이 측정공구 아랫면의 해당 고정 홈 (6) 사이에 오도록 맞추십시오. 측정공구를 시계 방향으로 돌려 회전대에 고정시키십시오.

회전대 (12) 의 다리를 높이 조정 나사 (10) 와 함께 돌려 푸십시오.

수준기 (8) 를 이용하여 회전대를 대략적으로 정렬하십시오.

측정공구가 회전대 (12) 에 설치되어 있는 경우, 미세 조정 나사 (11) 를 이용해 수직 레이저 라인을 기준점에 맞춰 정확하게 정렬할 수 있습니다.

작동

기계 시동

▶ 측정공구가 물에 젖거나 직사광선에 노출되지 않도록 하십시오.

▶ 극한의 온도 또는 온도 변화가 심한 환경에 측정공구를 노출시키지 마십시오. 예를 들어 장시간 차량 안에 측정공구를 두지 마십시오. 온도 편차가 심한 경우 계속 작동하기 전에 먼저 측정공구 온도도에 적응할 수 있게 하고 항상 정확도를 점검하십시오 (참조 „측정공구의 정확도 점검“, 페이지 25).

극한 온도에서나 온도 변화가 심한 환경에서 사용하면 측정공구의 정확도가 떨어질 수 있습니다.

▶ 측정공구가 외부와 세계 부딪히거나 떨어지지 않도록 주의하십시오. 측정공구에 외부 영향이 심하게 가해진 후에는 계속 작업하기 전에 항상 정확도를 점검해야 합니다 (참조 „측정공구의 정확도 점검“, 페이지 25).

▶ 측정공구를 운반할 때는 측정공구의 전원을 끄십시오. 스위치가 꺼진 상태에서는 레벨링 장치가 잠겨 있어 심한 움직임에 손상될 염려가 없습니다.

전원 스위치 작동

측정공구의 전원을 켜려면 전원 스위치 (7) 를 "On" (펜들럼 고정 기능 사용) 또는 "On" (자동 레벨링 기능 사용) 위치까지 밀어주십시오. 상태 표시기 (15) 의 불이 들어옵니다. 측정공구가 켜지면 앞쪽 발사구 (1) 에서 수평 레이저 라인이 나옵니다.

▶ 레이저빔이 사람이나 동물에 향하지 않도록 하고, 먼 거리에서라도 레이저빔 안을 들여다 보지 마십시오.

측정공구의 전원을 끄려면 전원 스위치 (7) 를 "Off" 위치로 미십시오. 상태 표시기 (15) 가 꺼집니다. 꺼질 때 셔들장치가 로크됩니다.

▶ 측정공구가 켜져 있는 상태에서 자리를 비우지 말고, 사용 후에는 측정공구의 스위치를 끄십시오. 레이저빔으로 인해 다른 사람의 눈이 부실 수 있습니다.

허용되는 최고 작동 온도 45 °C를 초과하면 레이저 다이오드 보호를 위해 전원이 꺼집니다. 냉각 후 측정공구가 작동 준비 상태로 전환되면 다시 전원을 켤 수 있습니다.

자동 꺼짐 기능 해제하기

측정공구는 작동된 지 30 분 후에 자동으로 꺼집니다.

자동 꺼짐을 비활성화하려면 측정공구를 켤 때 수직 모드 버튼 (16) 또는 수평 모드 버튼 (17) 을 3 초 간 눌러줍니다. 자동 꺼짐 기능이 비활성화되면 3 초 후에 레이저빔이 잠깐 동안 깜박입니다.

자동 꺼짐 기능을 활성화하려면 (버튼을 누를 필요 없이) 측정공구의 전원을 껐다가 다시 켭니다.

작동 모드

측정공구에는 여러 작동 모드가 있으며, 모드 간에 수시로 변경이 가능합니다. 수평 모드 및 수직 모드는 서로 독립적으로 켜고 끌 수 있습니다. 측정공구의 전원을 켜면 수평 모드로 설정되어 있습니다.

모든 작동 모드는 자동 레벨링 및 펜들럼 고정 기능을 함께 선택할 수 있습니다.

수평 모드(그림 B 참조)

수평 모드에서 측정공구는 앞쪽으로 수평 레이저 라인을 발생시킵니다.

수평 레이저 라인을 끄거나 켜려면, 수평 모드 버튼 (17) 을 누르십시오.

수직 모드 및 수직점(그림 C-D 참조)

측정공구에는 두 가지 수직 모드가 있습니다:

- 앞쪽으로 발사되는 수직 레이저 라인,
 - 앞쪽 및 우측으로 발사되는 수직 레이저 라인.
- 그 외에도 수직 모드에서 수직점은 항상 아래쪽으로 투사됩니다.

수직 모드를 켜거나 끄려면 혹은 수직 모드를 바꾸려면, 원하는 작동 모드가 나타날 때까지 수직 모드 버튼 (16) 을 누르십시오.

자동 레벨링 기능

자동 레벨링 기능을 이용한 작업

측정공구를 수평의 고정된 받침 위에 놓거나 회전대 (12) 에 고정하십시오.

자동 레벨링 기능을 이용하여 작업하려면 전원 스위치 (7) 를 "On" 위치로 밀어줍니다.

자동 레벨링 기능을 통해 셀프 레벨링 범위 ±3° 내 평평하지 않은 부분이 정도 자동으로 균형이 맞춰집니다. 레이저 라인이 더이상 움직이지 않으면 레벨링 작업이 종료됩니다.

측정공구가 위치한 바닥면이 3° 이상 경사져 있어서 자동 레벨링이 불가능하면 레이저빔이 빠른 속도로 깜박입니다.

이 경우 측정공구를 수평이 되게 놓고 자동 레벨링이 될 때까지 기다리십시오. 측정공구가 자동 레벨링 범위 $\pm 3^\circ$ 안에 들어오는 즉시 레이저빔은 지속적으로 켜집니다.

작동하는 동안 흔들리거나 위치가 변경되는 경우 측정공구는 자동으로 다시 레벨링됩니다. 레벨링이 끝나면 측정공구가 움직여져 발생하는 에러를 방지하기 위해 레이저빔이 기준 레벨에 맞는지 그 위치를 확인해 보십시오.

펜듈럼 고정 기능을 이용해 작업하기

펜듈럼 고정 기능을 이용하여 작업하려면 전원 스위치 (7) 를 "On" 위치로 밀어줍니다. 펜듈럼 고정 기능 표시기 (14) 에 적색이 점등되면 레이저 라인이 계속해서 천천히 깜박입니다.

펜듈럼 고정 기능을 이용한 작업 시 자동 레벨링 기능이 꺼져 있습니다. 측정공구를 손에 들고 있거나 경사진 바닥에 놓아도 됩니다. 레이저빔이 더 이상 레벨링되지 않으며, 반드시 직각으로 만나지 않습니다.

측정공구의 정확도 점검

정확도에 미치는 영향

가장 큰 영향을 미치는 것은 주위 온도입니다. 특히 바닥에서 위로 가면서 달라지는 온도로 인해 레이저빔이 굴절될 수 있습니다.

바닥 가까이에서 온도 변화가 가장 심하므로 가능한 면 측정공구를 삼각대에 조립한 후 작업면의 중앙에 설치하여 사용해야 합니다.

외부 요인 외에도 장비에 따른 요인(예: 전복 또는 충격의 강도)에 따라 차이가 있을 수 있습니다. 따라서 작업을 시작하기 전마다 레벨링 정확도를 점검하십시오.

수평 레이저 라인의 레벨링 및 높이의 정확도를 우선적으로 점검한 후 수직 레이저 라인의 레벨링 정확도를 각각 점검하십시오.

점검 시 측정공구가 한번이라도 최대 편차를 초과할 경우 **Bosch** 서비스 센터에 맡겨 수리하십시오.

수평선의 높이 정확도 확인하기

이 테스트를 하려면 벽 A와 B 사이에 단단한 바닥이 있는 5 m 구간의 빈 공간이 필요합니다.

- 측정공구를 벽 A에 가까이 하여 회전대 (12) 또는 삼각대 (24) 에 조립하거나 단단하고 평평한 바닥에 놓으십시오. 측정공구의 자동 레벨링 기능을 작동하십시오. 수평 모드 및 앞으로 발사되는 수직 레이저 라인 1개를 사용하는 수직 모드를 켜십시오.

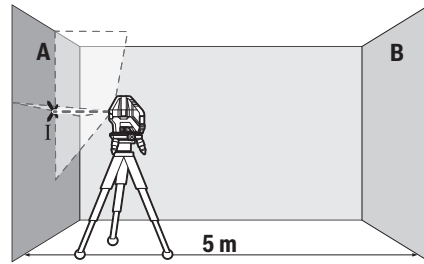

- 레이저를 가까이 있는 벽 A에 향하게 하고 측정공구를 레벨링하도록 하십시오. 레이저 라인이 벽면에서 교차되는 지점 중간을 표시하십시오(지점 I).

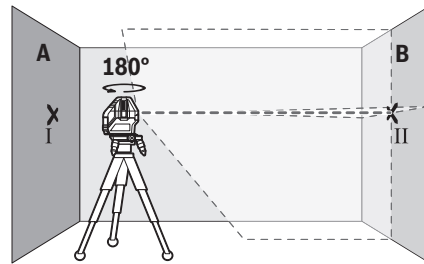

- 측정공구를 180° 돌려 레벨링한 후 레이저 라인의 교차 지점을 마주보는 벽 B(지점 II)에 표시하십시오.
- 측정공구를 돌릴 필요 없이 벽 B 근처에 두고, 전원을 켜 후 레벨링을 진행하십시오.

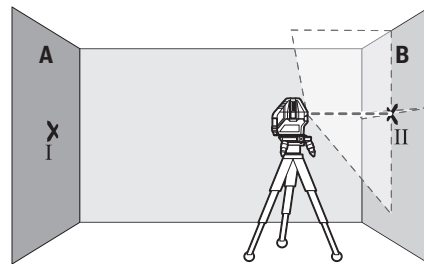

- 측정공구를 (삼각대 혹은 상황에 따라 받침대를 이용해) 레이저 라인의 교차점이 정확히 이전에 벽 B에 표시한 지점 II에 오도록 높이를 맞춰 정렬하십시오.

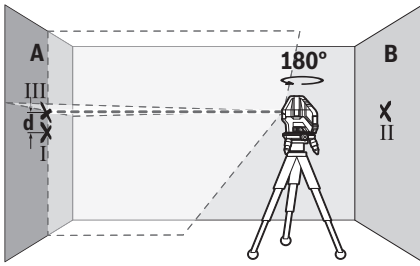

- 높이를 변경할 필요 없이 측정공구를 180° 회전 시킵니다. 벽 A에 향하게 하고, 수직 레이저 라인이 이미 표시된 지점 I을 관통하도록 정렬하십시오. 측정공구를 레벨링한 후 벽 A(지점 III)에서 레이저 라인의 교차점을 표시하십시오.
- 벽 A에 표시된 두 지점 I 및 III의 간격 **d**로 인해 실제 측정공구의 높이 편차가 생깁니다.

측정구간 $2 \times 5 \text{ m} = 10 \text{ m}$ 에서 최대 허용 편차는 다음과 같습니다.

$10 \text{ m} \times \pm 0.2 \text{ mm/m} = \pm 2 \text{ mm}$. 지점 I과 III 사이의 간격 **d**는 최대 2 mm입니다.

수평선의 레벨링 정확도 확인하기

점검을 위해서는 약 $5 \times 5 \text{ m}$ 정도의 빈 공간이 필요합니다.

- 측정공구를 벽 A와 벽 B 사이의 중앙에 있는 회전대 (12) 또는 삼각대 (24)에 조립하거나, 평평하고 단단한 바닥에 세우십시오. 측정공구의 자동 레벨링 기능을 작동하십시오. 수평 모드를 켜고 측정공구의 레벨링을 진행하십시오.

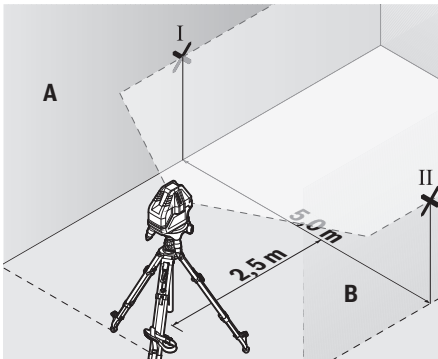

- 양쪽 벽에서 측정공구로부터 2.5 m 떨어진 거리에 레이저 라인의 중심을 표시하십시오(벽 A에 지점 I 및 벽 B에 지점 II).

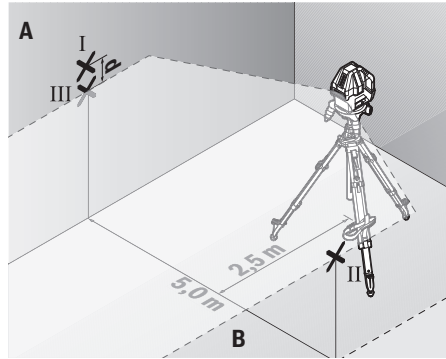

- 5 m 떨어진 곳에서 측정공구를 180° 회전시킨 후 레벨링하십시오.
- (삼각대 또는 필요에 따라 받침대를 이용하여) 레이저 라인의 중심이 이전에 표시한 벽 B의 지점 II에 오도록 측정공구의 높이를 정렬시키십시오.
- 벽 A에서 레이저 라인의 중심점을 지점 III(지점 I 수직으로 위쪽 또는 아래쪽)으로 표시하십시오.
- 벽 A에 표시된 두 지점 I 및 III의 간격 **d**로 인해 실제 측정공구의 수평 편차가 생깁니다.

측정구간 $2 \times 5 \text{ m} = 10 \text{ m}$ 에서 최대 허용 편차는 다음과 같습니다.

$10 \text{ m} \times \pm 0.2 \text{ mm/m} = \pm 2 \text{ mm}$. 지점 I과 III 사이의 간격 **d**는 최대 2 mm입니다.

수직선의 레벨링 정확도 확인하기

이 테스트를 진행하려면 (단단한 바닥에) 문의 양쪽으로 최소한 2.5 m의 공간이 필요합니다.

- 측정공구를 문 입구에서 2.5 m 떨어진 지점의 평평하고 단단한 바닥에 세우십시오(회전대 (12) 또는 삼각대에 세우지 않음). 측정공구의 자동 레벨링 기능을 작동하십시오. 앞쪽으로 발사되는 수직 레이저 라인 1개를 사용하는 수직 모드를 켜 후 레이저 라인을 문 입구에 맞춰 정렬하십시오. 측정공구에서 레벨링이 진행되도록 하십시오.

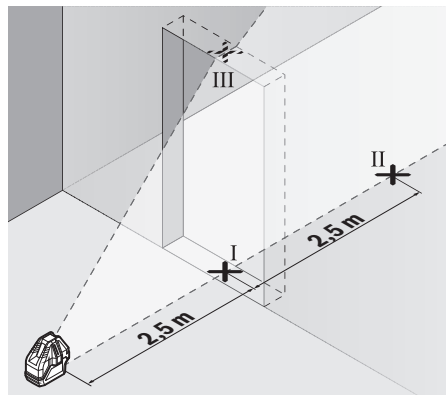

- 다른 측면의 출입구(지점 II)와 출입구 상단 가장자리(지점 III)에서 5 m 떨어진 곳에서 출입구(지

점 I)의 바닥에 수직 레이저 라인의 중심점을 표시하십시오.

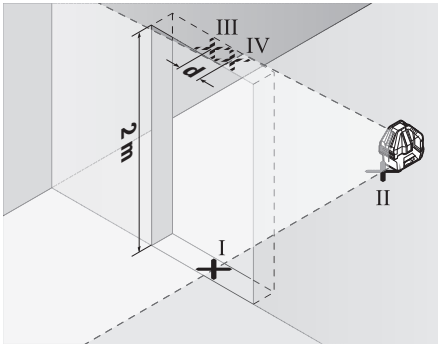

- 측정공구를 180° 돌려 지점 II 바로 뒤쪽에 있는 출입구의 다른 측면에 세워주십시오. 측정공구를 레벨링한 후 수직 레이저 라인의 중심이 지점 I 및 II를 지나도록 정렬하십시오.
- 출입구 상단 가장자리의 레이저 라인의 중심점을 지점 IV로 표시하십시오.
- 두 지점 III 및 IV의 간격 **d**로 인해 실제 측정공구의 직각 편차가 생깁니다.
- 출입구의 높이를 측정하십시오.

최대 허용 편차는 다음과 같이 계산합니다:

문 입구 높이 두배 × **0.2 mm/m**

예: 출입구 높이가 **2 m**의 경우 최대 편차

$2 \times 2 \text{ m} \pm 0.2 \text{ mm/m} = \pm 0.8 \text{ mm}$ 입니다. 따라서 지점 III 및 IV는 최대 **0.8 mm**를 벗어날 수 없습니다.

사용 방법

- ▶ 레이저 포인트 또는 레이저 라인 중심점은 표시 용도로만 사용하십시오. 레이저 포인트의 크기 또는 레이저 라인의 폭은 거리에 따라 달라집니다.

레이저 표적판으로 작업하기

레이저 표적판 (22)은 불리한 조건에서 그리고 거리가 많이 떨어진 곳에서 레이저빔의 가시성을 높여줍니다.

레이저 표적판 (22)의 반사면은 레이저 라인의 가시성을 높여주며, 표면이 투명하여 레이저 표적판의 뒷면을 통해서도 식별할 수 있습니다.

삼각대(액세서리)를 이용한 작업(그림 F 참조)

삼각대를 사용하여 높이를 조정하며, 안정적으로 측정할 수 있습니다. 측정공구를 삼각대에 조립하려면, 측정공구를 회전대 (12)에 설치하십시오.

5/8" 삼각대에 설치: 5/8" 삼각대 홀더 (9)와 함께 회전대를 5/8" 삼각대 (24) 혹은 일반 건축용 삼각대의 나사부 위에 놓습니다. 회전대를 삼각대 고정 나사로 고정하십시오.

1/4" 삼각대에 설치(그림 F 참조): 삼각대 어댑터 (18) (액세서리)를 회전대의 5/8" 삼각대 홀더 (9)에 체결하십시오. 1/4" 삼각대 홀더와 함께

삼각대 어댑터를 1/4" 삼각대 (19) 혹은 일반 카메라 삼각대의 나사부 위에 놓습니다. 삼각대 홀더를 삼각대 고정 나사로 고정하십시오.

측정공구의 전원을 켜기 전에 대략 삼각대의 방향을 맞추십시오.

레이저용 안경(액세서리)

레이저용 안경은 주변 조명을 걸러냅니다. 이를 통해 레이저의 빛이 더 밝게 보입니다.

- ▶ 레이저 보안경(액세서리)을 일반 보안경으로 사용하지 마십시오. 레이저 보안경은 레이저 광선을 보다 잘 감지하지만, 그렇다고 해서 레이저 광선으로부터 보호해주는 것은 아닙니다.

- ▶ 레이저 보안경(액세서리)을 선글라스 용도 또는 도로에서 사용하지 마십시오. 레이저 보안경은 자외선을 완벽하게 차단하지 못하며, 색상 분별력을 떨어뜨립니다.

작업 실례(그림 B-E 참조)

측정공구의 사용방법의 실례는 그림이 나와있는 면을 참고하십시오.

보수 정비 및 서비스

보수 정비 및 유지

항상 측정공구를 깨끗이 유지하십시오.

측정공구를 물이나 다른 액체에 넣지 마십시오.

물기있는 부드러운 천으로 오염된 부위를 깨끗이 닦으십시오. 세척제 또는 용제를 사용하지 마십시오.

특히 레이저빔 발사구 표면을 정기적으로 깨끗이하고 보푸라기가 없도록 하십시오.

측정공구는 반드시 함께 공급되는 안전 가방 (23)에 넣어 보관하고 운반하십시오.

수리하는 경우 측정공구를 보호 가방 (23)에 넣어 보내주십시오.

AS 센터 및 사용 문의

AS 센터에서는 귀하 제품의 수리 및 보수정비, 그리고 부품에 관한 문의를 받고 있습니다. 대체 부품에 관한 분해 조립도 및 정보는 인터넷에서도 찾아볼 수 있습니다 - www.bosch-pt.com

보수 사용 문의 팀에서는 보수의 제품 및 해당 액세서리에 관한 질문에 기꺼이 답변 드릴 것입니다.

문의나 대체 부품 주문 시에는 반드시 제품 네임 플레이트에 있는 10자리의 부품번호를 알려 주십시오.

콜센터

080-955-0909

다른 AS 센터 주소는 아래 사이트에서 확인할 수 있습니다:

www.bosch-pt.com/serviceaddresses

처리

측정공구, 액세서리 및 포장 등은 친환경적인 방법으로 재활용될 수 있도록 분류하십시오.



측정공구 및 배터리를 가정용 쓰레기에 버리지 마십시오!

ไทย

กฎระเบียบเพื่อความปลอดภัย



ส่งเครื่องมือวัดให้ช่างผู้เชี่ยวชาญตรวจสอบและไขอะไหล่เปลี่ยนของแทเท่านั้น หากไม่ใช่เครื่องมือวัดตามคำแนะนำเหล่านี้ ระบบป้องกันเบ็ดเสร็จในเครื่องมือวัดอาจได้รับผลกระทบ

อย่าทำให้อายุการใช้งานของเครื่องมือวัดนี้สั้นลง เก็บรักษาคำแนะนำเหล่านี้ไว้ให้ดี และหากเครื่องมือวัดนี้ถูกส่งต่อไปยังผู้อื่น ให้ส่งมอบคำแนะนำเหล่านี้ไปด้วย

- ▶ ข้อควรระวัง - การใช้อุปกรณ์ทำงานหรืออุปกรณ์ปรับเปลี่ยนอื่น ๆ นอกเหนือไปจากที่ระบุไว้ในที่นี้ หรือการใช้วิธีการอื่น ๆ อาจนำไปสู่การสัมผัสกับรังสีอันตรายได้
- ▶ เครื่องมือวัดนี้จัดส่งมาพร้อมป้ายเตือนแสงเลเซอร์ (แสดงในหน้าภาพประกอบของเครื่องมือวัด)
- ▶ หากข้อความของป้ายเตือนแสงเลเซอร์ไม่ได้เป็นภาษาของท่าน ให้ติดสติ๊กเกอร์ที่จัดส่งมาที่พิมพ์เป็นภาษาของท่านที่ส่งมอบก่อนใช้งานครั้งแรก



อย่าส่องลำแสงเลเซอร์ไปยังคนหรือสัตว์ และตัวท่านเองอย่าจ้องมองเข้าไปในลำแสงเลเซอร์โดยตรงหรือลำแสงเลเซอร์สะท้อน การกระทำดังกล่าวอาจทำให้คนตาพร่า ทำให้เกิดอุบัติเหตุ หรือทำให้ดวงตาเสียหายได้

- ▶ ถ้าแสงเลเซอร์เข้าตา ต้องปิดตาและหันศีรษะออกจากลำแสงในทันที
- ▶ อย่าทำการเปลี่ยนแปลงใดๆ ที่อุปกรณ์เลเซอร์
- ▶ อย่าใช้แว่นสำหรับมองแสงเลเซอร์ (อุปกรณ์เสริม) เป็นแว่นนิรภัย แว่นสำหรับมองแสงเลเซอร์ใช้สำหรับมองลำแสงเลเซอร์ให้เห็นชัดเจนยิ่งขึ้น แต่ไม่ได้ช่วยป้องกันรังสีเลเซอร์
- ▶ อย่าใช้แว่นสำหรับมองแสงเลเซอร์ (อุปกรณ์เสริม) เป็นแว่นกันแดดหรือใส่ซันรยนต์แว่นสำหรับมองแสงเลเซอร์ไม่สามารถป้องกันรังสีอัลตราไวโอเล็ต (UV) ได้ อย่างสมบูรณ์ และยังลดความสามารถในการมองเห็นสี
- ▶ ส่งเครื่องมือวัดให้ช่างผู้เชี่ยวชาญตรวจสอบและไขอะไหล่เปลี่ยนของแทเท่านั้น

ทั้งนี้เพื่อให้มั่นใจได้ว่าจะสามารถใช้งานเครื่องมือวัดได้อย่างปลอดภัยเสมอ

- ▶ อย่าให้เด็กใช้เครื่องมือวัดด้วยเลเซอร์โดยไม่ควบคุมดูแล เด็กๆ อาจทำให้บุคคลอื่นหรือตนเองตาพร่าโดยไม่ตั้งใจ
- ▶ อย่าใช้เครื่องมือวัดในสภาพแวดล้อมที่เสี่ยงต่อการระเบิด ซึ่งเป็นที่ที่มีของเหลว แก๊ส หรือฝุ่นที่ติดไฟได้ในเครื่องมือวัดสามารถเกิดประกายไฟซึ่งอาจจุดฝุ่นละอองหรือไอระเหยให้ติดไฟได้



ต้องกันเครื่องมือวัดและอุปกรณ์ประกอบที่มีคุณสมบัติเป็นแม่เหล็กให้ห่างจากวัตถุปลูกถ่ายในร่างกายและอุปกรณ์ทางการแพทย์อื่นๆ เครื่องมือปรับจิงหระการเค้นของหัวใจด้วยไฟฟ้าหรือบีมอินซูลิน แม่เหล็กของเครื่องมือวัดและอุปกรณ์ประกอบจะสร้างสนามแม่เหล็กซึ่งสามารถทำให้วัตถุปลูกถ่ายในร่างกายและอุปกรณ์ทางการแพทย์อื่นๆ ทำงานบกพร่องได้

- ▶ ต้องกันเครื่องมือวัดและอุปกรณ์ประกอบที่มีคุณสมบัติเป็นแม่เหล็กให้ห่างจากสื่อนำข้อมูลที่มีคุณสมบัติเป็นแม่เหล็กและอุปกรณ์ที่ไวต่อแรงดึงดูดแม่เหล็ก แม่เหล็กของเครื่องมือวัดและอุปกรณ์ประกอบสามารถทำให้ข้อมูลสูญหายอย่างเรียกกลับไม่ได้

รายละเอียดผลิตภัณฑ์และข้อมูล

จำเพาะ

กรุณาดูภาพประกอบในส่วนหน้าของคู่มือการใช้งาน

ประโยชน์การใช้งานของเครื่อง

เครื่องมือวัดนี้ใช้สำหรับกำหนดและตรวจสอบเส้นแนวนอนและเส้นแนวตั้ง รวมทั้งจุดตั้ง เครื่องมือวัดนี้เหมาะสำหรับใช้ภายในอาคาร

ส่วนประกอบที่แสดงภาพ

ลำดับเลขของส่วนประกอบอ้างอิงถึงส่วนประกอบของเครื่องมือวัดที่แสดงในหน้าภาพประกอบ

- (1) ช่องทางออกลำแสงเลเซอร์
- (2) ตัวล็อกฝาช่องใส่แบตเตอรี่
- (3) ฝาช่องใส่แบตเตอรี่
- (4) หมายเลขเครื่อง
- (5) ป้ายเตือนแสงเลเซอร์
- (6) ร่องยึดเครื่องมือวัด
- (7) สวิตช์เปิด-ปิด

- (8) ระดับน้ำของแท่นหมุน
 - (9) ช่องประกอบขาตั้งแบบสามขาขนาด 5/8 นิ้วของแท่นหมุน
 - (10) สกรูปรับความสูงของแท่นหมุน
 - (11) สกรูปรับละเอียดของแท่นหมุน
 - (12) แท่นหมุน
 - (13) ร่องยึดแท่นหมุน
 - (14) ไฟแสดงการล็อกแม่ขึ้น
 - (15) ไฟแสดงสถานะ
 - (16) ปุ่มการทำงานในแนวตั้ง
 - (17) ปุ่มการทำงานในแนวนอน
 - (18) อะแดปเตอร์ของขาตั้งแบบสามขา^{a)}
 - (19) ขาตั้งแบบสามขาขนาด 1/4 นิ้ว^{a)}
 - (20) แวนสำหรับมองแสงเลเซอร์^{a)}
 - (21) แม่เหล็ก^{a)}
 - (22) แผ่นป้ายหมายเลเซอร์^{a)}
 - (23) กระเป๋ใส่เครื่องมือวัด
 - (24) ขาตั้งแบบสามขาขนาด 5/8 นิ้ว^{a)}
- a) อุปกรณ์ประกอบที่แสดงภาพหรืออธิบายไม่รวมอยู่ในการจัดส่งมาตรฐาน กรุณาดูอุปกรณ์ประกอบทั้งหมดในรายการแสดงอุปกรณ์ประกอบของเรา

ข้อมูลทางเทคนิค

เลเซอร์แบบเส้น	GLL 3-15 X
หมายเลขสินค้า	3 601 K63 M..
ช่วงการใช้งาน ^{A)}	
- เส้นเลเซอร์	15 ม.
- จุดตั้ง	5 ม.
ความแม่นยำการหาระดับเส้นเลเซอร์ ^{B)C)D)}	±0.2 มม./ม.
ย่านการหาระดับอัตโนมัติ ปกติ	±3°
ระยะเวลาที่หาระดับ ปกติ	< 4 วินาที
อุณหภูมิใช้งาน	-10 °C ... +45 °C
อุณหภูมิเก็บรักษา	-20 °C ... +70 °C
ความสูงใช้งานเหนือระดับอ้างอิง สูงสุด	2000 ม.
ความชื้นสัมพัทธ์ สูงสุด	90 %

เลเซอร์แบบเส้น	GLL 3-15 X
ระดับมลพิษตาม IEC 61010-1	2 ^{E)}
ระดับเลเซอร์	2
ชนิดเลเซอร์	< 1 มิลลิวัตต์, 630-650 นาโนเมตร
C ₆	1
การบานออกของลำแสง	
- เส้นเลเซอร์	1.5 mrad
- จุดตั้ง	1.5 mrad
ช่องประกอบขาตั้งแบบสามขา ^{F)}	5/8"
แบตเตอรี่	4 × 1.5 โวลท์ LR6 (AA)
ระยะเวลาทำงาน ประมาณ ^{C)}	
- กับเส้นเลเซอร์ 1 เส้น	24 ชม.
- กับเส้นเลเซอร์ 2 เส้น	14 ชม.
- กับเส้นเลเซอร์ 3 เส้น	10 ชม.
น้ำหนักตามระเบียบการ EPTA-Procedure 01:2014	0.54 กก.
ขนาด (ความยาว × ความกว้าง × ความสูง)	
- ไม่มีแท่นหมุน	122 × 83 × 129 มม.
- มีแท่นหมุน	∅ 151 × 203 มม.
ระดับการป้องกัน (ยกเว้น แบตเตอรี่)	IP 54 (ป้องกันฝุ่นและน้ำกระเด็นเป็ยก)
A) ย่านการทำงานอาจลดลงหากมีสถานะแวดล้อมที่ไม่เหมาะสม (ค.ย. เช่น แสงอาทิตย์ส่องโดยตรง)	
B) จากโรงงาน	
C) ที่ 20-25 °C	
D) ค่าที่ระบุเป็นค่าที่กำหนดตามสภาพแวดล้อมปกติ (เช่น ไม่มี การสั่นสะเทือน ปราศจากหมอกควัน ไมโครแสงแดดโดยตรง) ความผันผวนของอุณหภูมิที่มากเกินไปอาจส่งผลให้เกิดความเบี่ยงเบนต่อความแม่นยำได้	
E) เกิดขึ้นเฉพาะมลพิษที่ไม่นำไฟฟ้า ยกเว้นบางครั้งนำไฟฟ้าได้ชั่วคราวที่มีสาเหตุจากการกลั่นตัวที่คิดว่าอาจจะเกิดขึ้น	
F) ใช้ได้เฉพาะร่วมกับแท่นหมุนเท่านั้น	

สำหรับการระบุเครื่องมือวัดของท่านอย่างชัดเจน กรุณาดูหมายเลขเครื่อง (4) บนแผ่นป้ายรุ่น

การติดตั้ง

การใส่/การเปลี่ยนแบตเตอรี่

สำหรับการใช้งานเครื่องมือวัด ขอแนะนำให้ใส่แบตเตอรี่อัลคาไลน์แมงกานีส

เปิดฝาช่องใส่แบตเตอรี่ (3) โดยยกบนตัวล็อค (2) และถอดฝาช่องใส่แบตเตอรี่ออก ใส่แบตเตอรี่เข้าไป

ขณะใส่แบตเตอรี่ต้องดูให้ขั้วแบตเตอรี่อยู่ในตำแหน่งที่ถูกต้องตามที่กำหนดไว้ที่ด้านในช่องใส่แบตเตอรี่

หากไฟแสดงสถานะ (15) กระพริบ คุณต้อง

เปลี่ยนแบตเตอรี่ทุกก้อนพร้อมกันเสมอ โดยใช้แบตเตอรี่จากผู้ผลิตรายเดียวกันทั้งหมดและมีความจุเท่ากันทุกก้อน

- ▶ **เมื่อไม่ใช้งานเครื่องมือวัดเป็นเวลานาน ต้องถอดแบตเตอรี่ออก** แบตเตอรี่ในเครื่องมือตัดอาจกัดกร่อนในระหว่างเก็บรักษาเป็นเวลานาน และปล่อยประจุออกเองได้

การทำงานกับแท่นหมุน (ดูภาพประกอบ A)

เมื่อใช้แท่นหมุน (12) ท่านสามารถหมุนเครื่องมือวัด 360° รอบจุดติดตั้งตรงกลางที่มองเห็นได้เสมอ ดังนั้นท่านจึงสามารถจัดวางเส้นเลเซอร์ได้อย่างแม่นยำโดยไม่ต้องเปลี่ยนตำแหน่งเครื่องมือวัด

วางเครื่องมือวัดบนแท่นหมุน (12) โดยให้ร่องยึด (13) ของแท่นหมุนระหว่างร่องยึด (6) พอดีกับด้านล่างของเครื่องมือวัด มุมเครื่องมือวัดตามเข็มนาฬิกาเพื่อล็อคบนแท่นหมุน

คลายสกรูของแท่นหมุน (12) ออกด้วยสกรูปรับความสูง (10)

จัดแนวแท่นหมุนด้วยระดับน้ำ (8)

หากติดตั้งเครื่องมือวัดบนแท่นหมุน (12) คุณสามารถจัดแนวเส้นเลเซอร์แนวตั้งให้ตรงกับจุดอ้างอิงด้วยสกรูปรับละเอียด (11)

การปฏิบัติงาน

การเริ่มต้นปฏิบัติงาน

- ▶ **ป้องกันไม่ให้เครื่องมือวัดได้รับความชื้นและโดนแสงแดดส่องโดยตรง**
- ▶ **อย่าให้เครื่องมือวัดได้รับอุณหภูมิที่สูงมาก หรือรับอุณหภูมิที่เปลี่ยนแปลงมาก** ต. ย. เช่น อย่ายกเครื่องมือวัดไว้ในรถยนต์เป็นเวลานาน หากเกิดความผันผวนของอุณหภูมิสูงขึ้น ปล่อยให้เครื่องมือวัดปรับอุณหภูมิก่อนและตรวจสอบความแม่นยำก่อนดำเนินการต่อ (ดู "การตรวจสอบความแม่นยำของเครื่องมือวัด", หน้า 31)
- ▶ **อุณหภูมิที่สูงมากหรืออุณหภูมิที่เปลี่ยนแปลงมากอาจส่งผลต่อความแม่นยำของเครื่องมือวัด**

- ▶ **หลีกเลี่ยงอย่าให้เครื่องมือวัดตกหล่นหรือถูกกระแทกอย่างรุนแรง** เมื่อเครื่องมือวัดถูกกระแทกจากภายนอกอย่างแรง ขอแนะนำให้ทำการตรวจสอบความแม่นยำทุกครั้งก่อนนำมาใช้งานต่อ (ดู "การตรวจสอบความแม่นยำของเครื่องมือวัด", หน้า 31)

- ▶ **ปิดเครื่องมือวัดเมื่อขนย้าย** เมื่อปิดสวิตช์ชุดที่าระดับจะถูกล็อค ถ้าไม่เช่นนั้นการเคลื่อนไหวอย่างรุนแรงอาจทำให้ชุดที่าระดับเสียหายได้

การเปิด-ปิดเครื่อง

เมื่อต้องการ**เปิดสวิตช์** เครื่องมือวัด ให้ดันสวิตช์เปิด-ปิด (7) ไปที่ตำแหน่ง "On" (สำหรับการทำงานโดยที่แบล็กล็อกอยู่) หรือไปที่ตำแหน่ง "On" (สำหรับการทำงานด้วยการทำระดับอัตโนมัติ) ไฟแสดงสถานะ (15) จะสว่างขึ้น เครื่องมือวัดจะปล่อยเส้นเลเซอร์แนวระนาบออกจากช่องทางออกด้านหน้า (1)

- ▶ **อย่าส่องลำแสงเลเซอร์ไปยังคนหรือสัตว์ และอย่าส่องมองลำแสงเลเซอร์แม้จะอยู่ในระยะไกล**

เมื่อต้องการ**ปิดสวิตช์** เครื่องมือวัด ให้เลื่อนสวิตช์เปิด-ปิด (7) ไปที่ตำแหน่ง "Off" ไฟแสดงสถานะ (15) จะดับลง เมื่อปิดสวิตช์ชุดจะถูกตั้งจะถูกล็อค

- ▶ **อย่าวางเครื่องมือวัดที่เปิดสวิตช์ทิ้งไว้โดยไม่มีผู้ดูแล และให้ปิดสวิตช์เครื่องมือวัดเมื่อเลิกใช้งาน** คนอื่นอาจตาพร่าจากแสงเลเซอร์ได้

หากเครื่องมืออุณหภูมิเกินกว่าอุณหภูมิใช้งานสูงสุดที่อนุญาตคือ 45 °C เครื่องจะปิดสวิตช์ ทั้งนี้เพื่อปกป้องเลเซอร์ไดโอด เมื่อเครื่องมือวัดเย็นลงแล้ว เครื่องพร้อมจะทำงาน ให้เปิดสวิตช์เครื่องอีกครั้งได้

การยกเลิกการปิดอัตโนมัติ

เครื่องมือวัดจะปิดสวิตช์โดยอัตโนมัติหลังใช้งานไป 30 นาที เมื่อต้องการยกเลิกการปิดอัตโนมัติ ให้กดปุ่มสำหรับการทำงานตามแนวตั้ง (16) หรือปุ่มสำหรับการทำงานตามแนวนอน (17) ค้างไว้ 3 วินาทีเมื่อเปิดสวิตช์เครื่องมือวัด เมื่อการปิดสวิตช์โดยอัตโนมัติถูกยกเลิกแล้ว หลังจากนั้น 3 วินาทีลำแสงเลเซอร์จะกะพริบสั้นๆ

เมื่อต้องการเรียกใช้งานการปิดสวิตช์โดยอัตโนมัติ ให้ปิดสวิตช์เครื่องมือวัดและเปิดสวิตช์อีกครั้ง (โดยไม่ได้กดปุ่มไว้)

รูปแบบการทำงาน

เครื่องมือวัดนี้มีหลายรูปแบบการทำงาน ซึ่งท่านสามารถสลับใช้ได้ตลอดเวลา สามารถเปิดและปิดสวิตช์การทำงานตามแนวนอนและแนวตั้งได้แยกกันได้อย่างอิสระ หลังจากเปิดสวิตช์ เครื่องมือวัดจะอยู่ในโหมดการทำงานตามแนวนอน

ท่านสามารถเลือกทำงานด้วยการปรับระดับอัตโนมัติและโดยที่แป้นล็อกอยู่

การทำงานตามแนวนอน (รูปภาพประกอบ B)

ในการทำงานตามแนวนอน เครื่องมือวัดจะส่งเส้นเลเซอร์แนวนอนไปทางด้านหน้า

กดปุ่มการทำงานตามแนวนอน (17) เพื่อเปิดหรือปิดสวิตช์เส้นเลเซอร์แนวนอน

การทำงานในแนวตั้งและจุดตั้ง (รูปภาพประกอบ C-D)

เครื่องมือวัดนี้มีประเภทการทำงานตามแนวตั้งสองรูปแบบ:

- เส้นเลเซอร์แนวตั้งไปทางด้านหน้า,
- เส้นเลเซอร์แนวตั้งไปทางด้านหน้าและด้านข้างขวา

นอกจากนี้จุดตั้งจะถูกฉายลงด้านล่างในการทำงานในแนวตั้ง ในการเปิดหรือปิดสวิตช์การทำงานตามแนวตั้ง รวมถึงการเปลี่ยนสู่โหมดการทำงานตามแนวตั้ง ให้กดปุ่มการทำงานตามแนวตั้ง (16) ซ้ำๆ จนถึงโหมดการทำงานที่ต้องการ

การหาระดับอัตโนมัติ

การทำงานด้วยการหาระดับอัตโนมัติ

วางเครื่องมือวัดบนพื้นที่ยื่นคองและราบเสมอกันหรือติดตั้งเข้าบนฐานยึดหมุนได้ (12)

สำหรับการทำงานโดยมีการหาระดับอัตโนมัติ ให้ดันสวิตช์เปิด-ปิด (7) ไปที่ตำแหน่ง "On"

การหาระดับอัตโนมัติจะปรับความไม่ราบเรียบให้สมดุลภายในการปรับระดับอัตโนมัติ $\pm 3^\circ$ ได้เอง การหาระดับจะเสร็จสมบูรณ์ในทันทีที่เส้นเลเซอร์ไม่เคลื่อนไหวอีกต่อไป

หากฟังก์ชันการหาระดับอัตโนมัติไม่สามารถทำงานได้ ต. ย. เช่น เนื่องจากพื้นผิวที่เครื่องมือวัดตั้งอยู่เอียงเบนมากกว่า 3° จากระนาบราบ ลำแสงเลเซอร์จะกะพริบเร็วๆ

ในกรณีนี้ให้ตั้งเครื่องมือวัดบนพื้นราบเสมอกัน และรอให้เกิดการหาระดับอัตโนมัติ ทันทีที่เครื่องมือวัดอยู่ในย่านการหาระดับอัตโนมัติ $\pm 3^\circ$ ลำแสงเลเซอร์จะส่องสว่างอย่างต่อเนื่อง

ในกรณีที่มีพื้นลั่นสะเทือนหรือเปลี่ยนตำแหน่งขณะทำงาน เครื่องมือวัดจะทำการปรับระดับโดยอัตโนมัติอีกครั้ง เพื่อหลีกเลี่ยงความผิดพลาดอันเกิดจากการเลื่อนเครื่องมือวัด ให้ตรวจสอบตำแหน่งของลำแสงเลเซอร์กับจุดอ้างอิงหลังการหาระดับ

การทำงานโดยที่แป้นล็อกอยู่

สำหรับการทำงานโดยที่แป้นล็อกอยู่ ให้ดันสวิตช์เปิด-ปิด (7) ไปที่ตำแหน่ง "On" ตัวแสดงสำหรับการล็อกแป้น (14) ติดขึ้นสีแดงและเส้นเลเซอร์จะกะพริบซ้ำๆ อย่างต่อเนื่อง

สำหรับการทำงานโดยที่แป้นล็อกอยู่ การปรับระดับอัตโนมัติจะปิดทำงาน คุณสามารถถือเครื่องมือวัดไว้ในมือหรือวางไว้

บนพื้นผิวที่ลาดเอียง ลำแสงเลเซอร์จะไม่ปรับระดับอีกต่อไปและไม่จำเป็นต้องรีเซ็ตในแนวตั้งตรงซึ่งกันและกันอีกต่อไป

การตรวจสอบความแม่นยำของเครื่องมือวัด

ผลกระทบต่อความแม่นยำ

อุณหภูมิรอบด้านมีผลต่อความแม่นยำมากที่สุด โดยเฉพาะอย่างยิ่งความแตกต่างของอุณหภูมิจากพื้นขึ้นไปทีละระดับสูงกว่าสามารถเบี่ยงเบนลำแสงเลเซอร์ได้ เนื่องจากบริเวณใกล้กับพื้นมีการเบี่ยงเบนของอุณหภูมิมากที่สุด หากเป็นไปได้ จึงควรติดตั้งเครื่องมือวัดไว้บนขาตั้งแบบสามขา และวางเครื่องมือวัดตรงกลางพื้นที่ทำงาน

นอกจากสาเหตุและปัจจัยภายนอกแล้ว สาเหตุและปัจจัยเฉพาะตัวอุปกรณ์เอง (ต. ย. เช่น การตกหล่น หรือการกระแทกอย่างรุนแรง) อาจนำไปสู่การเบี่ยงเบนได้ด้วย ดังนั้นให้ตรวจสอบความแม่นยำการทำการระดับทุกครั้งก่อนเริ่มทำงาน ในเบื้องต้น ให้ตรวจสอบความแม่นยำค่าความสูงและความแม่นยำการทำการระดับของเส้นเลเซอร์แนวนอน จากนั้นจึงตรวจสอบความแม่นยำการทำการระดับของเส้นเลเซอร์แนวตั้ง หากเครื่องมือวัดเบี่ยงเบนเกินค่าเบี่ยงเบนสูงสุดในระหว่างการทดสอบครั้งใดครั้งหนึ่ง ให้ส่งเครื่องให้ศูนย์บริการหลังการขาย Bosch ซ่อมแซม

การตรวจสอบความแม่นยำค่าความสูงของเส้นแนวนอน

สำหรับการตรวจสอบ ต้องใช้ระยะทางวัดข้างแปล่า 5 ม. บนพื้นผิวที่มีนัยระหว่างผนัง A และ B

- ติดตั้งเครื่องมือวัดเข้าบนแท่นหมุน (12) หรือขาตั้งแบบสามขา (24) หรือวางเครื่องมือวัดบนพื้นผิวที่มั่นคงและราบเสมอกันใกล้กับผนัง A เปิดสวิตช์เครื่องมือวัดในรูปแบบการทำงานด้วยการหาระดับอัตโนมัติ เปิดสวิตช์การทำงานตามแนวนอนและการทำงานตามแนวตั้ง ด้วยเส้นเลเซอร์ตั้งตรงไปทางด้านหน้า

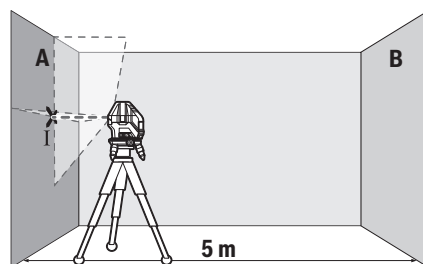

- ชี้นำเลเซอร์ไปยังผนังฝั่งใกล้ A และปล่อยให้เครื่องมือวัดทำการระดับ ค่าเครื่องมือวัดตรงกลางจุดตรงที่เส้นเลเซอร์ไขว้กันที่ผนัง A (จุด I)

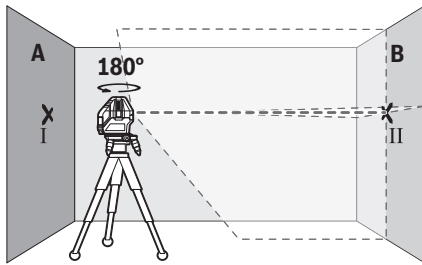

- หมุนเครื่องมือวัดไป 180° ปล่อยให้เครื่องมือวัดทำระดับและทำเครื่องหมายที่จุดไขว้ของเส้นเลเซอร์บนผนังฝั่งตรงข้าม B (จุด II)
- วางเครื่องมือวัดใกล้ผนัง B โดยไม่หมุนเครื่อง เปิดสวิตช์เครื่องมือวัดและปล่อยให้ทำระดับ

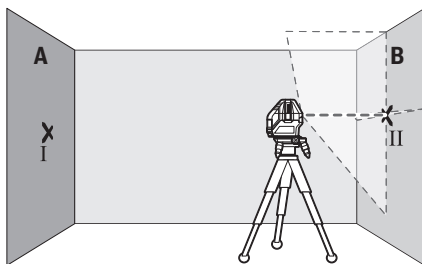

- วางแนวความสูงของเครื่องมือวัด (โดยปรับที่ขาตั้งแบบสามขาหรือใช้สิ่งของรองข้างใต้ หากจำเป็น) ในลักษณะให้จุดไขว้ของเส้นเลเซอร์ตกลงบนจุดเครื่องหมายอื่นก่อน II บนผนัง B อย่างพอดีบพอดี

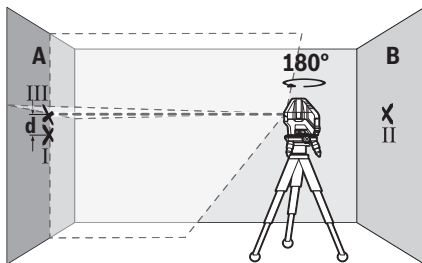

- หมุนเครื่องมือวัดไป 180° โดยไม่เปลี่ยนความสูงซีเลเซอร์ไปยังผนัง A ในลักษณะให้เส้นเลเซอร์แนวตั้งวิ่งผ่านจุดที่ทำเครื่องหมายไว้แล้ว I ปล่อยให้เครื่องมือวัดทำระดับและทำเครื่องหมายที่จุดไขว้ของเส้นเลเซอร์บนผนัง A (จุด III)
- ความต่าง **d** ของจุดเครื่องหมายทั้งสอง I และ III บนผนัง A แสดงความเบี่ยงเบนความสูงที่แท้จริงของเครื่องมือวัดที่ระยะทางวัด 2 × 5 ม. = 10 ม. ความเบี่ยงเบนสูงสุดที่อนุญาตคือ:

10 ม. × ±0.2 มม./ม. = ±2 มม. ดังนั้นความต่าง **d** ระหว่างจุด I และ III ต้องไม่เกิน 2 มม.

การตรวจสอบความแม่นยำการทำระดับของเส้นแนวนอน สำหรับการตรวจสอบ ต้องใช้พื้นผิววางเปล่าประมาณ 5 × 5 ม.

- ประกอบเครื่องมือวัดเข้าบนแท่นหมุน (12) หรือขาตั้งแบบสามขา (24) หรือวางเครื่องบนพื้นผิวที่มั่นคงและราบเสมอกันโดยให้อยู่ตรงกลางระหว่างผนัง A และ B เปิดสวิตช์เครื่องมือวัดในรูปแบบการทำงานด้วยการทำระดับอัตโนมัติ เปิดสวิตช์การทำงานตามแนวนอนและให้เครื่องมือปรับระดับ

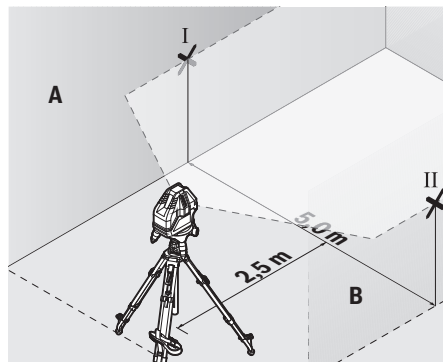

- ที่ระยะ 2.5 ม. ห่างจากเครื่องมือวัด ให้ทำเครื่องหมายตรงกลางเส้นเลเซอร์บนผนังทั้งสองด้าน (จุด I บนผนัง A และจุด II บนผนัง B)

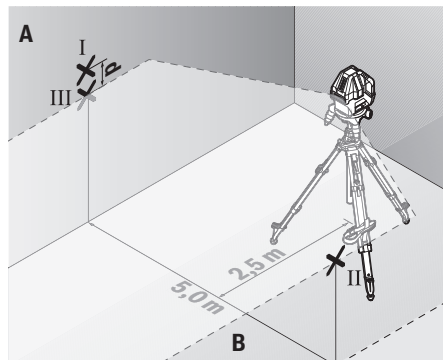

- ตั้งเครื่องมือวัดห่างออกไป 5 ม. โดยหมุนเครื่องไป 180° และปล่อยให้เครื่องมือวัดทำระดับ
- ปรับความสูงของเครื่องมือวัด (โดยปรับที่ขาตั้งแบบสามขาหรือใช้สิ่งของรองข้างใต้ หากจำเป็น) ในลักษณะให้จุดกลางของเส้นเลเซอร์ตกลงบนจุดเครื่องหมายอื่นก่อน II บนผนัง B อย่างพอดีบพอดี

- ทำเครื่องหมายตรงกลางเส้นเลเซอร์เป็นจุด III (อยู่ในแนวตรงเหนือหรือใต้จุด I) บนผนัง A
- ความต่าง **d** ของจุดเครื่องหมายทั้งสอง I และ III บนผนัง A แสดงความเบี่ยงเบนของเครื่องมือวัดจากระนาบภายในขณะนั้น

ที่ระยะทางวัด $2 \times 5 \text{ ม.} = 10 \text{ ม.}$ ความเบี่ยงเบนสูงสุดที่อนุญาตคือ:

$10 \text{ ม.} \times \pm 0.2 \text{ มม./ม.} = \pm 2 \text{ มม.}$ ดังนั้นความต่าง **d** ระหว่างจุด I และ III ต้องไม่เกิน **2 มม.**

การตรวจสอบความแม่นยำการหาระดับของเส้นแนวตั้ง

สำหรับการตรวจสอบ ต้องใช้ช่องประตูที่มีพื้นที่ว่างแต่ละด้านห่างจากประตูอย่างน้อย 2.5 เมตร (บนพื้นผิวที่มั่นคง)

- วางเครื่องมือวัดไว้บนพื้นผิวที่มั่นคงและราบเสมอกัน โดยให้ห่างจากช่องประตู 2.5 ม. (ไม่วางบนแท่นหมุน (12) หรือบนขาตั้งแบบสามขา) เปิดสวิตช์เครื่องมือวัดในรูปแบบการทำงานด้วยการหาระดับอัตโนมัติ เปิดสวิตช์การทำงานตามแนวตั้งด้วยเส้นเลเซอร์ไปทางด้านหน้า และชี้เลเซอร์ไปที่ช่องเปิดที่ประตู ปล่อยให้เครื่องมือวัดหาระดับ

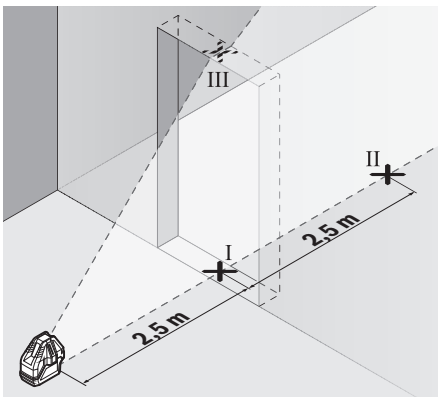

- ทำเครื่องหมายตรงกลางเส้นเลเซอร์แนวตั้งที่พื้นของช่องประตู (จุด I) ที่ระยะห่างออกไป 5 เมตรเลยไปอีกด้านหนึ่งของช่องประตู (จุด II) และที่ขอบด้านบนของช่องประตู (จุด III)

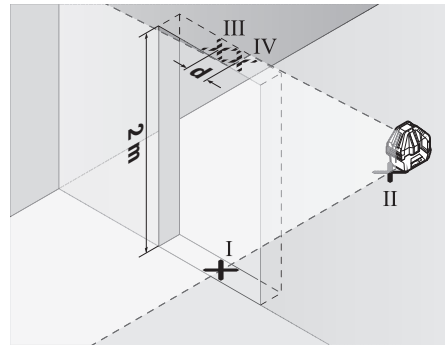

- หมุนเครื่องมือวัดไป 180° และวางเครื่องไว้อีกด้านหนึ่งของช่องประตูตรงหลังจุด II ปล่อยให้เครื่องมือวัดหาระดับ และวางแนวเส้นเลเซอร์แนวตั้งในลักษณะให้จุดกลางของเส้นเลเซอร์วิ่งผ่านจุด I และ II อย่างพอดีพอดี
- ทำเครื่องหมายตรงกลางเส้นเลเซอร์ที่ขอบด้านบนของช่องประตูให้เป็นจุด IV
- ความต่าง **d** ของจุดเครื่องหมายทั้งสอง III และ IV แสดงความเบี่ยงเบนที่แท้จริงของเครื่องมือวัดจากแนวตั้ง
- วัดความสูงของช่องประตู

ความเบี่ยงเบนสูงสุดที่อนุญาตคำนวณดังต่อไปนี้:

สองเท่าของความสูงช่องประตู $\times 0.2 \text{ มม./ม.}$

ตัวอย่าง: ถ้าความสูงช่องประตูคือ 2 ม. ความเบี่ยงเบนสูงสุดต้องไม่เกิน

$2 \times 2 \text{ ม.} \times \pm 0.2 \text{ มม./ม.} = \pm 0.8 \text{ มม.}$ ดังนั้นจุด III และ IV ต้องห่างจากกันไม่เกิน **0.8 มม.**

ข้อแนะนำในการทำงาน

- ▶ **ทำเครื่องหมายตรงกลางจุดเลเซอร์หรือเส้นเลเซอร์เสมอ** ขนาดของจุดเลเซอร์และความกว้างของเส้นเลเซอร์เปลี่ยนแปลงตามระยะทาง

การทำงานกับแผ่นเป้าหมายเลเซอร์

แผ่นเป้าหมายเลเซอร์ (22) ช่วยให้มองเห็นลำแสงเลเซอร์ได้ดียิ่งขึ้นในสภาวะที่ไม่เหมาะสมและในระยะทางไกลๆ ส่วนพื้นผิวสะท้อนกลับของแผ่นเป้าหมายเลเซอร์ (22) ช่วยให้มองเห็นเส้นเลเซอร์ได้ดียิ่งขึ้น เนื่องจากมีส่วนโปร่งใส จึงสามารถมองเห็นเส้นเลเซอร์จากทางด้านหลังของแผ่นพื้นผิวเป้าหมายเลเซอร์ได้ด้วย

การทำงานกับขาตั้งแบบสามขา (อุปกรณ์เสริม) (ดูภาพประกอบ F)

ขาตั้งแบบสามขาช่วยให้สามารถทำการวัดได้อย่างมั่นคงและปรับความสูงได้ สำหรับการติดตั้งเครื่องมือวัดบนขาตั้งแบบสามขา ให้วางวางเครื่องมือวัดบนแท่นหมุน (12)

การติดตั้งบนขาตั้งแบบสามขาขนาด 5/8 นิ้ว: วางแท่นหมุนพร้อมช่องประกอบของขาตั้งแบบสามขาขนาด 5/8 นิ้ว (9) บนเกลียวของขาตั้งแบบสามขาขนาด 5/8 นิ้ว s (24) หรือขาตั้งกลองที่มีจำหน่ายทั่วไป ยึดแท่นหมุนโดยขันสลักเกลียวของขาตั้งแบบสามขาเข้าให้แน่น

การติดตั้งบนขาตั้งแบบสามขาขนาด 1/4 นิ้ว (ดูภาพประกอบ F): ขันอะแดปเตอร์ของขาตั้งแบบสามขา (18) (อุปกรณ์เสริม) เข้าในช่องประกอบขาตั้งแบบสามขาขนาด 5/8 (9) ของแท่นหมุน วางอะแดปเตอร์ของขาตั้งแบบสามขาพร้อมช่องประกอบขาตั้งแบบสามขาขนาด 1/4 นิ้ว บนเกลียวของขาตั้งแบบสามขาขนาด 1/4 นิ้ว (19) หรือขาตั้งกลองที่มีจำหน่ายทั่วไป ยึดอะแดปเตอร์ของขาตั้งแบบสามขาโดยขันสลักเกลียวของขาตั้งแบบสามขาเข้าให้แน่น ปรับขาตั้งแบบสามขาอย่างคร่าวๆ ก่อนเปิดสวิทช์เครื่องมือวัด

แว่นสำหรับมองแสงเลเซอร์ (อุปกรณ์ประกอบ)

แว่นสำหรับมองแสงเลเซอร์ช่วยกรองแสงภาวะแสงภายนอกออกไป ทำให้ตามองเห็นแสงเลเซอร์ได้ชัดเจนยิ่งขึ้น

▶ **อย่าใช้แว่นสำหรับมองแสงเลเซอร์ (อุปกรณ์เสริม) เป็นแว่นนิรภัย** แว่นสำหรับมองแสงเลเซอร์ใช้สำหรับมองลำแสงเลเซอร์ให้เห็นชัดเจนยิ่งขึ้น แต่ไม่ได้ช่วยป้องกันรังสีเลเซอร์

▶ **อย่าใช้แว่นสำหรับมองแสงเลเซอร์ (อุปกรณ์เสริม) เป็นแว่นกันแดดหรือใส่ขั้วรถยนต์** แว่นสำหรับมองแสงเลเซอร์ไม่สามารถป้องกันรังสีอัลตราไวโอเล็ต (UV) ได้ อย่างสมบูรณ์ และยังลดความสามารถในการมองเห็นสี

ตัวอย่างการปฏิบัติงาน (ดูภาพประกอบ B-E)

ตัวอย่างการใช้งานที่เป็นไปได้ของเครื่องมือวัด
กรุณาดูในหน้าภาพประกอบ

การบำรุงรักษาและการบริการ

การบำรุงรักษาและการทำความสะอาด

รักษาเครื่องมือวัดให้สะอาดตลอดเวลา

อย่าจุ่มเครื่องมือวัดลงในน้ำหรือของเหลวอื่นๆ เช็ดสิ่งสกปรกออกด้วยผ้านุ่มที่เปียกหมาดๆอย่าใช้สารซักฟอกหรือตัวทำละลาย

ทำความสะอาดพื้น

ผิวตรงช่องทางออกลำแสงเลเซอร์เป็นประจำ และเอาใจใส่อย่าให้ขุยผ้าติด

เก็บรักษาและขนย้ายเครื่องมือวัดเฉพาะเมื่อบรรจุอยู่ในกระเป๋าสีเครื่องมือวัด (23) เท่านั้น

ในการมีซ่อมแซม ให้ส่งเครื่องมือวัดโดยบรรจุลงในกระเป๋าสีเครื่องมือวัด (23)

การบริการหลังการขายและการให้คำปรึกษาการใช้งาน

ศูนย์บริการหลังการขายของเรายินดีตอบคำถามของท่านที่เกี่ยวกับการบำรุงรักษาและการซ่อมแซมผลิตภัณฑ์รวมทั้งเรื่องอะไหล่ ภาพเขียนแบบการประกอบและข้อมูลเกี่ยวกับอะไหล่ กรุณาดูใน: www.bosch-pt.com

ทีมงานที่ปรึกษาของ บอช ยินดีให้ข้อมูลเกี่ยวกับผลิตภัณฑ์ของเราและอุปกรณ์ประกอบต่างๆ

เมื่อต้องการสอบถามและสั่งซื้ออะไหล่ กรุณาแจ้งหมายเลขสินค้า 10 หลักบนแผ่นป้ายรุ่นของผลิตภัณฑ์ทุกครั้ง

ไทย

ไทย บริษัท โรเบิร์ต บอช จำกัด

ออฟฟายโอ เซ็นเตอร์ อาคาร 1 ชั้น 5

เลขที่ 2525 ถนนพระราม 4

แขวงคลองเตย เขตคลองเตย กรุงเทพฯ 10110

โทร: +66 2012 8888

แฟกซ์: +66 2064 5800

www.bosch.co.th

ศูนย์บริการซ่อมและฝึกอบรม บอช

อาคาร ลานชาลาทาวเวอร์ ชั้น G ห้องเลขที่ 2

บ้านเลขที่ 10/11 หมู่ 16

ถนนศรีนครินทร์ ตำบลบางแก้ว อำเภอบางพลี

จังหวัดสมุทรปราการ 10540

ประเทศไทย

โทรศัพท์ 02 7587555

โทรสาร 02 7587525

สามารถดูที่อยู่ศูนย์บริการอื่นๆ ได้ที่:

www.bosch-pt.com/serviceaddresses

การกำจัดขยะ

เครื่องมือวัด อุปกรณ์ประกอบ และที่บ่อ ต้องนำไปแยกประเภทวัสดุเพื่อส่งเข้าสู่กระบวนการรีไซเคิลที่เป็นมิตรต่อสิ่งแวดล้อม



อย่าทิ้งเครื่องมือวัดและแบตเตอรี่ลงในขยะบ้าน!

Bahasa Indonesia

Petunjuk Keselamatan



Petunjuk lengkap ini harus dibaca dan diperhatikan agar tidak terjadi bahaya dan Anda dapat bekerja dengan aman saat menggunakan alat ukur ini. Apabila alat ukur tidak digunakan sesuai dengan petunjuk yang disertakan, keamanan alat ukur dapat terganggu. Janganlah sekali-kali menutupi atau melepas label keselamatan kerja yang ada pada alat ukur ini. **SIMPAN PETUNJUK INI DENGAN BAIK DAN BERIKAN KEPADA PEMILIK ALAT UKUR BERIKUTNYA.**

- ▶ **Perhatian** – jika perangkat pengoperasian atau perangkat pengaturan atau prosedur lain selain yang dituliskan di sini digunakan, hal ini dapat menyebabkan terjadinya paparan radiasi yang berbahaya.
- ▶ Alat pengukur dikirim dengan tanda peringatan laser (ditandai dengan ilustrasi alat pengukur di halaman grafis).
- ▶ Jika teks pada tanda peringatan laser tidak tertulis dalam bahasa negara Anda, tempelkan label yang tersedia dalam bahasa negara Anda di atas label berbahasa Inggris sebelum Anda menggunakan alat ukur pertama kalinya.



Jangan melihat sinar laser ataupun mengarahkannya kepada orang lain atau hewan baik secara langsung maupun dari pantulan. Sinar laser dapat membutakan seseorang, menyebabkan kecelakaan atau merusak mata.

- ▶ **Jika radiasi laser mengenai mata, tutup mata Anda dan segera gerakkan kepala agar tidak terkena sorotan laser.**
- ▶ **Jangan mengubah peralatan laser.**
- ▶ **Jangan gunakan kacamata pelihat laser (aksesori) sebagai kacamata pelindung.** Kacamata pelihat laser digunakan untuk mendeteksi sinar laser dengan lebih baik, namun tidak melindungi dari sinar laser.
- ▶ **Jangan gunakan kacamata pelihat laser (aksesori) sebagai kacamata hitam atau di jalan raya.** Kacamata pelihat laser tidak menawarkan perlindungan penuh terhadap sinar UV dan mengurangi persepsi warna.
- ▶ **Perbaiki alat ukur hanya di teknisi ahli resmi dan gunakan hanya suku cadang asli.** Dengan demikian, keselamatan kerja dengan alat ukur ini selalu terjamin.
- ▶ **Jangan biarkan anak-anak menggunakan alat ukur laser tanpa pengawasan.** Hal ini dapat menyilaukan orang lain atau diri sendiri secara tidak sengaja.
- ▶ **Jangan mengoperasikan alat ukur di area yang berpotensi meledak yang di dalamnya terdapat cairan, gas, atau serbuk yang dapat terbakar.** Di dalam

alat pengukur dapat terjadi bunga api, yang lalu menyulut debu atau uap.



Jauhkan alat pengukur dan aksesoris magnetis dari alat implan dan perangkat medis semacamnya, seperti misalnya alat pacu jantung atau pompa insulin. Magnet pada alat pengukur dan aksesoris menciptakan medan yang dapat memengaruhi fungsi alat implan dan perangkat medis.

- ▶ **Jauhkan alat pengukur dan aksesoris magnetis dari media penyimpanan data magnetis dan perangkat yang sensitif terhadap magnet.** Daya magnet dari perkakas listrik dan aksesoris dapat mengakibatkan data-data hilang secara permanen.

Spesifikasi produk dan performa

Perhatikan ilustrasi yang terdapat pada bagian depan panduan pengoperasian.

Tujuan penggunaan

Alat pengukur dirancang untuk menentukan dan memeriksa garis horizontal dan vertikal dan juga titik tegak lurus. Alat pengukur ini cocok untuk penggunaan di dalam gedung.

Ilustrasi komponen

Nomor-nomor pada ilustrasi komponen sesuai dengan gambar alat pengukur pada halaman gambar.

- (1) Outlet sinar laser
- (2) Pengunci tutup kompartemen baterai
- (3) Tutup kompartemen baterai
- (4) Nomor seri
- (5) Label peringatan laser
- (6) Alur pengencang alat pengukur
- (7) Tombol on/off
- (8) Waterpas landasan putar
- (9) Dudukan tripod 5/8" pada landasan putar
- (10) Sekrup penyatel ketinggian landasan putar
- (11) Sekrup penyatel landasan putar
- (12) Landasan putar
- (13) Alur pengencang landasan putar
- (14) Display penguncian pendulum
- (15) Indikator status
- (16) Tombol mode vertikal
- (17) Tombol mode horizontal
- (18) Adaptor tripod^{a)}
- (19) Tripod 1/4^{na)}
- (20) Kacamata laser^{a)}
- (21) Magnet^{a)}
- (22) Reflektor sinar laser^{a)}
- (23) Tas pelindung

(24) Tripod 5/8^{ns)}

- a) **Aksesori yang ada pada gambar atau yang dijelaskan tidak termasuk dalam lingkup pengiriman standar. Semua aksesori yang ada dapat Anda lihat dalam program aksesori kami.**

Data teknis

Lasar garis	GLL 3-15 X
Nomor seri	3 601 K63 M..
Area kerja ^{A)}	
– Garis laser	15 m
– Titik tegak lurus	5 m
Akurasi perataan garis laser ^{B)C)D)}	±0,2 mm/m
Rentang perataan otomatis khusus	±3°
Waktu perataan khusus	< 4 s
Suhu pengoperasian	-10°C ... +45°C
Suhu penyimpanan	-20°C ... +70°C
Tinggi penggunaan maks. di atas tinggi acuan	2000 m
Kelembapan relatif maks.	90%
Tingkat polusi sesuai dengan IEC 61010-1	2 ^{E)}
Kelas laser	2
Jenis laser	< 1 mW, 630–650 nm
C ₆	1
Divergensi	
– Garis laser	1,5 mrad
– Titik tegak lurus	1,5 mrad
Dudukan tripod ^{F)}	5/8"
Baterai	4 × 1,5 V LR6 (AA)
Durasi pengoperasian sekitar ^{C)}	
– Dengan 1 garis laser	24 h
– Dengan 2 garis laser	14 h
– Dengan 3 garis laser	10 h
Berat sesuai dengan EPTA-Procedure 01:2014	0,54 kg
Dimensi (panjang × lebar × tinggi)	
– Tanpa landasan putar	122 × 83 × 129 mm
– Dengan landasan putar	∅ (diameter) 151 × 203 mm

Lasar garis**GLL 3-15 X**

Jenis perlindungan (selain kompartemen baterai) IP 54 (terlindung dari debu dan percikan air)

- A) Area kerja dapat berkurang akibat keadaan lingkungan yang tidak menguntungkan (seperti sinar matahari langsung).
 B) Penyetelan pabrik
 C) pada **20–25 °C**
 D) Nilai yang ditentukan memerlukan kondisi lingkungan normal hingga kondisi lingkungan menguntungkan (misalnya tidak ada getaran, tidak ada kabut, tidak ada asap, tidak ada sinar matahari langsung). Perubahan suhu yang drastis dapat menyebabkan penyimpangan akurasi.
 E) Hanya polusi nonkonduktif yang terjadi, namun terkadang muncul konduktivitas sementara yang disebabkan oleh kondensasi.
 F) hanya tersedia dalam kombinasi dengan landasan putar
 Untuk mengidentifikasi alat ukur secara jelas terdapat nomor seri **(4)** pada label tipe.

Cara memasang**Memasang/mengganti baterai**

Untuk pengoperasian alat ukur disarankan memakai baterai mangan alkali.

Untuk membuka tutup kompartemen baterai **(3)**, tekan pengunci **(2)** dan lepaskan tutup kompartemen baterai. Masukkan baterai.

Pastikan baterai terpasang pada posisi kutub yang benar sesuai gambar di dalam kompartemen baterai.

Jika display status **(15)** berkedip, baterai harus diganti.

Selalu ganti semua baterai sekaligus. Hanya gunakan baterai dari produsen dan dengan kapasitas yang sama.

- **Keluarkan baterai dari alat pengukur jika tidak digunakan dalam waktu yang lama.** Jika baterai disimpan di dalam alat pengukur untuk waktu yang lama, baterai dapat berkarat dan dayanya akan habis dengan sendirinya.

Bekerja dengan landasan putar (lihat gambar A)

Dengan bantuan landasan putar **(12)** alat pengukur dapat diputar sebesar 360° pada titik pusat. Untuk itu, garis laser dapat diatur secara tepat tanpa mengubah posisi alat pengukur.

Letakkan alat pengukur pada landasan putar **(12)** sedemikian rupa sehingga alur pengencang **(13)** landasan putar terpasang pas di antara alur pengencang terkait **(6)** pada bagian bawah alat pengukur. Putar alat pengukur searah jarum jam untuk mengunci alat pada landasan putar. Lepaskan kaki landasan putar **(12)** dengan sekrup penyetelan ketinggian **(10)**.

Sejajarkan landasan putar kasar menggunakan waterpas **(8)**. Jika alat pengukur dipasang pada landasan putar **(12)**, Anda dapat menajarkan garis laser vertikal dengan sekrup penyetel **(11)** tepat di titik referensi.

Penggunaan

Cara penggunaan

- ▶ **Lindungilah alat ukur dari cairan dan sinar matahari langsung.**
- ▶ **Jauhkan alat pengukur dari suhu atau perubahan suhu yang ekstrem.** Jangan biarkan alat pengukur berada terlalu lama di dalam kendaraan. Saat perubahan suhu besar, biarkan alat ukur menyesuaikan suhu lingkungan terlebih dulu dan selalu lakukan pemeriksaan akurasi sebelum melanjutkan pekerjaan dengan (lihat „Pemeriksaan keakuratan alat ukur“, Halaman 38). Pada suhu atau perubahan suhu ekstrem, ketepatan alat pengukur dapat terganggu.
- ▶ **Hindari guncangan atau benturan yang keras pada alat ukur.** Apabila setelah terjadi pengaruh eksternal yang kuat pada alat ukur, disarankan untuk memeriksa akurasi alat ukur sebelum digunakan kembali (lihat „Pemeriksaan keakuratan alat ukur“, Halaman 38).
- ▶ **Matikan alat ukur saat memindahkan.** Jika alat ukur dimatikan, unit pendulum akan terkunci yang dapat rusak jika terkena guncangan.

Mengaktifkan/menonaktifkan perkakas listrik

Untuk **menghidupkan** alat pengukur, geser tombol on/off (7) ke posisi "On" (untuk bekerja dengan penguncian pendulum) atau ke posisi "On" (untuk bekerja dengan perataan otomatis). Indikator status (15) menyala. Setelah dihidupkan, alat pengukur segera memancarkan garis laser horizontal dari outlet depan (1).

- ▶ **Jangan mengarahkan sinar laser pada orang lain atau binatang dan jangan melihat ke sinar laser, juga tidak dari jarak jauh.**

Untuk **mematikan** alat pengukur, geser tombol on/off (7) ke posisi "Off". Indikator status (15) padam. Unit pendulum akan terkunci ketika alat pengukur dimatikan.

- ▶ **Jangan biarkan alat ukur yang aktif berada di luar pengawasan dan matikan alat ukur setelah digunakan.** Sinar laser dapat menyilaukan mata orang lain.

Saat suhu pengoperasian melebihi batas maksimum yang diperbolehkan sebesar 45 °C, alat akan mati untuk melindungi dioda laser. Setelah alat pengukur menjadi dingin, alat pengukur siap dipakai dan bisa dihidupkan kembali.

Mematikan penonaktifan otomatis

Alat pengukur mati secara otomatis setelah 30 menit pengoperasian.

Untuk menonaktifkan penonaktifan otomatis, tekan dan tahan tombol mode vertikal (16) atau tombol mode horizontal (17) selama 3 detik saat menghidupkan alat pengukur. Jika penonaktifan otomatis dinonaktifkan, sinar laser berkedip singkat setelah 3 detik.

Untuk mengaktifkan penonaktifan otomatis, matikan alat pengukur dan hidupkan kembali (tanpa menekan tombol).

Mode pengoperasian

Alat pengukur dilengkapi beberapa mode pengoperasian yang dapat diganti setiap saat. Mode horizontal dan vertikal dapat diaktifkan dan dinonaktifkan secara terpisah. Setelah dihidupkan, alat pengukur berada pada mode horizontal.

Semua mode pengoperasian dapat dipilih dengan levelling otomatis serta dengan penguncian pendulum.

Mode horizontal (lihat gambar B)

Pada mode horizontal, alat pengukur memancarkan garis laser horizontal ke depan.

Untuk mengaktifkan atau menonaktifkan garis laser horizontal, tekan tombol mode horizontal (17).

Mode vertikal dan titik tegak lurus (lihat gambar C-D)

Alat pengukur dilengkapi dua mode pengoperasian vertikal:

- Garis laser vertikal ke depan,
- Garis laser vertikal ke depan dan ke sisi kanan.

Selain itu, titik tegak lurus selalu diproyeksikan ke bawah dalam mode vertikal.

Untuk mengaktifkan atau menonaktifkan mode vertikal serta untuk mengganti jenis mode vertikal, tekan tombol mode vertikal (16) beberapa kali hingga mencapai mode pengoperasian yang diinginkan.

Levelling otomatis

Bekerja dengan perataan otomatis

Pasang alat pengukur pada permukaan yang datar dan stabil atau kencangkan pada landasan putar (12).

Untuk penggunaan dengan levelling otomatis, geser tombol on/off (7) ke posisi "On".

Levelling otomatis akan menyeimbangkan keadaan yang tidak rata di dalam kisaran levelling dari $\pm 3^\circ$ secara otomatis. Levelling akan segera berhenti setelah garis laser tidak lagi bergerak.

Jika perataan otomatis tidak dapat dilakukan, misalnya karena permukaan posisi alat pengukur menyimpang lebih dari 3° dari posisi horizontal, sinar laser akan berkedip dalam tempo cepat.

Pada situasi tersebut, letakkan alat pengukur secara mendatar dan tunggu sampai dilakukan perataan otomatis. Begitu alat pengukur berada di dalam area perataan otomatis sebesar $\pm 3^\circ$, sinar laser akan menyala terus-menerus.

Jika selama pengoperasian, alat pengukur diguncangkan atau dipindahkan, alat pengukur akan melakukan levelling secara otomatis. Setelah penyetelan ini, periksalah posisi dari sinar laser-sinar laser terhadap titik-titik patokan, untuk menghindari terjadinya kesalahan yang diakibatkan karena alat pengukur dipindahkan.

Bekerja dengan pengunci pendulum

Untuk pengerjaan dengan penguncian pendulum, geser tombol on/off (7) ke posisi "On". Display penguncian pendulum (14) menyala merah dan garis laser berkedip dalam tempo lambat.

Saat bekerja dengan penguncian pendulum, perataan otomatis dinonaktifkan. Alat pengukur dapat dipegang dengan tangan atau ditempatkan pada permukaan yang miring. Sinar laser tidak lagi diratakan dan tidak lagi tegak lurus satu sama lain.

Pemeriksaan keakuratan alat ukur

Pengaruh terhadap ketelitian

Suhu sekitar memberikan pengaruh terbesar. Khususnya perbedaan suhu dari tanah ke atas dapat mempengaruhi sinar laser.

Berhubung stratifikasi suhu di dekat tanah yang paling besar, alat ukur perlu dipasang pada tripod jika memungkinkan dan dipasang di tengah area pengerjaan.

Selain pengaruh dari luar, pengaruh khusus perangkat juga dapat menyebabkan kerusakan (seperti misalnya benturan atau guncangan keras). Oleh karena itu, periksa ketepatan levelling terlebih dahulu sebelum memulai proses.

Pertama periksa tingginya serta ketepatan perataan garis laser horizontal, kemudian ketepatan perataan garis laser vertikal.

Jika pada pemeriksaan akurasi ternyata hasil pengukuran melebihi ambang batas maksimal, bawa alat pengukur ke Service Center **Bosch** untuk reparasi.

Periksa ketepatan tinggi dari garis horizontal

Untuk melakukan pemeriksaan ini diperlukan jarak kosong sepanjang 5 m pada permukaan yang stabil di antara dua dinding A dan B.

- Pasang alat pengukur di dekat dinding A pada landasan putar (**12**) atau pada tripod (**24**), atau letakkan pada permukaan yang stabil dan rata. Hidupkan alat pengukur dalam pengoperasian dengan perataan otomatis. Aktifkan mode horizontal dan mode vertikal dengan garis laser vertikal ke depan.

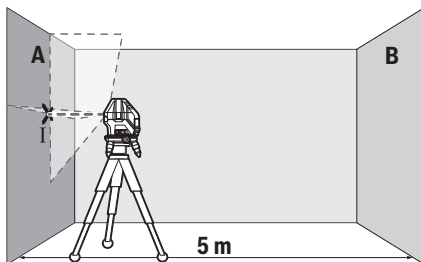

- Bidikkan laser pada dinding A dan biarkan alat ukur melakukan levelling otomatis. Tandai bagian tengah titik di mana garis laser akan saling berpotongan pada dinding (titik I).

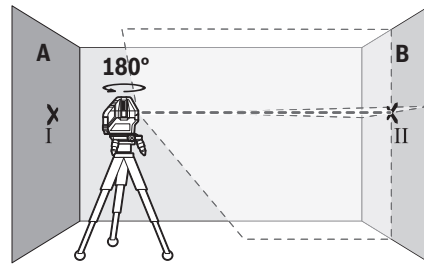

- Putar alat ukur sebesar 180°, biarkan alat ukur melakukan levelling otomatis dan tandai titik persimpangan garis laser di dinding B (titik II).
- Letakkan alat ukur tanpa diputar di dekat dinding B, aktifkan alat ukur dan biarkan alat ukur melakukan levelling otomatis.

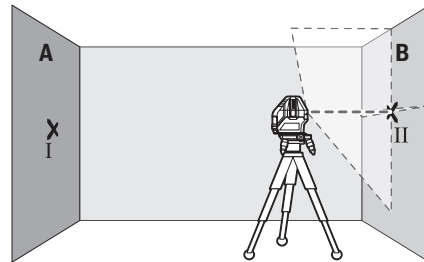

- Sesuaikan tinggi alat ukur (dengan bantuan tripod atau jika perlu ditopang) sehingga titik perpotongan garis laser tepat menyentuh titik yang ditandai sebelumnya II pada dinding B.

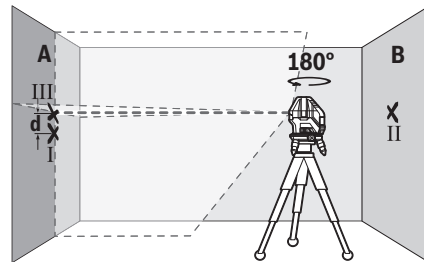

- Putar alat ukur sebesar 180° tanpa mengubah ketinggian. Arahkan alat ukur pada dinding A sehingga garis laser vertikal melewati titik yang telah ditandai I. Biarkan alat ukur melakukan levelling secara otomatis dan tandai titik persimpangan garis laser di dinding A (titik III).
- Selisih **d** dari kedua titik yang ditandai I dan III pada dinding A memberikan deviasi ketinggian alat ukur yang sebenarnya.

Pada jarak ukur $2 \times 5 \text{ m} = 10 \text{ m}$ simpangan maksimal yang diperbolehkan adalah sebesar:

$10 \text{ m} \times \pm 0,2 \text{ mm/m} = \pm 2 \text{ mm}$. Selisih **d** antara titik I dan III hanya diperbolehkan maksimum 2 mm.

Periksa ketepatan perataan garis laser horizontal

Untuk pemeriksaan, diperlukan permukaan kosong sekitar 5×5 m.

- Pasang alat pengukur di bagian tengah antara dinding A dan B di atas landasan putar (**12**) atau tripod (**24**), atau pasang dengan kencang di atas permukaan yang stabil dan rata. Hidupkan alat pengukur dalam pengoperasian dengan perataan otomatis. Aktifkan mode horizontal dan biarkan alat pengukur melakukan perataan.

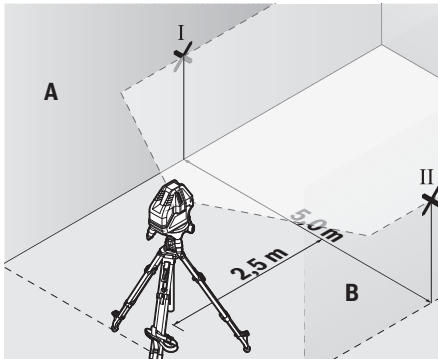

- Pada jarak 2,5 m dari alat ukur, tandai titik tengah garis laser (titik I pada dinding A dan titik II pada dinding B) pada kedua dinding.

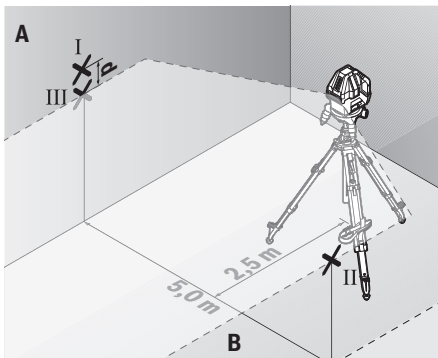

- Pasang alat pengukur dengan diputar sebesar 180° pada jarak 5 m dan biarkan alat ukur melakukan levelling.
- Sesuaikan alat ukur pada ketinggian yang cukup (dengan bantuan tripod atau dengan alas jika perlu), hingga titik tengah garis laser tepat berada sebelum titik II dan pada dinding B.
- Tandai titik tengah garis laser pada dinding A sebagai titik III (vertika melalui dan di bawah titik I).
- Selisih d dari kedua titik yang ditandai I dan III pada dinding A memberikan deviasi alat ukur pada garis horizontal.

Pada jarak ukur $2 \times 5 \text{ m} = 10 \text{ m}$ simpangan maksimal yang diperbolehkan adalah sebesar:

$10 \text{ m} \times \pm 0,2 \text{ mm/m} = \pm 2 \text{ mm}$. Selisih d antara titik I dan III hanya diperbolehkan maksimum 2 mm.

Memeriksa ketelitian pengukuran garis tegak lurus

Untuk melakukan pemeriksaan ini diperlukan bukaan pintu dengan setiap sisi pintu minimal 2,5 m.

- Pasang alat pengukur pada jarak 2,5 m dari bukaan pintu di atas permukaan tanah yang stabil dan rata (bukan di atas landasan putar (**12**) atau tripod). Hidupkan alat pengukur dalam pengoperasian dengan perataan otomatis. Aktifkan mode vertikal dengan garis laser vertikal ke depan dan arahkan garis laser pada bukaan pintu. Biarkan alat pengukur melakukan perataan.

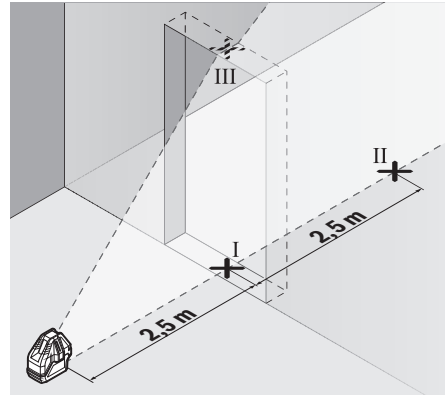

- Tandai tengah garis laser vertikal di bagian bawah bukaan pintu (titik I), pada jarak 5 m di sisi lain pada bukaan pintu (titik II) dan di tepi atas bukaan pintu (titik III).

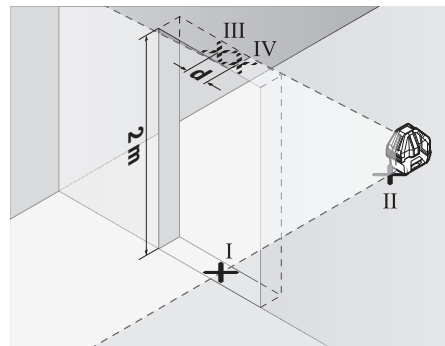

- Putar alat ukur sebesar 180° dan letakkan pada sisi lain dari bukaan pintu tepat di belakang titik II. Biarkan alat ukur melakukan levelling dan sesuaikan garis laser vertikal sehingga titik tengahnya tepat melewati titik I dan II.
- Tandai titik tengah garis laser di bagian atas bukaan pintu sebagai titik IV.
- Selisih d dari kedua titik yang ditandai III dan IV menyatakan deviasi alat ukur untuk garis vertikal.
- Ukur tinggi bukaan pintu.

Simpangan maksimal yang diperbolehkan dihitung sebagai berikut:

dua kali tinggi bukaan pintu $\times 0,2 \text{ mm/m}$

contoh: Pada ketinggian bukaan pintu 2 m simpangan maksimal diperbolehkan sebesar $2 \times 2 \text{ m} \times \pm 0,2 \text{ mm/m} = \pm 0,8 \text{ mm}$. Titik III dan IV dapat terpisah maksimal sejauh 0,8 mm.

Petunjuk pemakaian

- ▶ **Selalu hanya gunakan bagian tengah titik laser atau garis laser untuk menandai.** Besarnya titik laser atau lebarnya garis laser berubah sesuai dengan perubahan jarak.

Bekerja dengan reflektor (alat pemantulan)

Reflektor (alat pemantulan) (22) meningkatkan visibilitas sinar laser dalam kondisi yang tidak menguntungkan dan jarak yang lebih besar.

Permukaan pantul dari reflektor sinar laser (22) akan meningkatkan visibilitas garis laser, garis laser juga dapat terlihat melalui permukaan yang transparan dari bagian belakang reflektor sinar laser.

Bekerja dengan tripod (aksesori) (lihat gambar F)

Tripod memberi posisi pengukuran yang stabil dan ketinggian yang dapat diatur. Untuk memasang alat pengukur pada tripod, letakkan alat pengukur pada landasan putar (12).

Pemasangan pada tripod 5/8": Letakkan landasan putar dengan dudukan tripod 5/8" (9) pada ulir tripod 5/8" (24) atau tripod konstruksi standar. Kencangkan landasan putar dengan sekrup pengencang tripod.

Pemasangan pada tripod 1/4" (lihat gambar F): Pasang adaptor tripod (18) (aksesori) pada dudukan tripod 5/8" (9) landasan putar. Letakkan adaptor tripod dengan dudukan tripod 1/4" pada ulir tripod 1/4" (19) atau tripod foto standar. Kencangkan adaptor tripod dengan sekrup pengencang tripod.

Atur tripod sebelum menghidupkan alat ukur.

Kacamata laser (aksesori)

Kacamata laser berfungsi menyaring sinar yang berada di sekitar. Dengan demikian, sinar laser akan terlihat lebih terang untuk mata.

- ▶ **Jangan gunakan kacamata pelihat laser (aksesori) sebagai kacamata pelindung.** Kacamata pelihat laser digunakan untuk mendeteksi sinar laser dengan lebih baik, namun tidak melindungi dari sinar laser.
- ▶ **Jangan gunakan kacamata pelihat laser (aksesori) sebagai kacamata hitam atau di jalan raya.** Kacamata pelihat laser tidak menawarkan perlindungan penuh terhadap sinar UV dan mengurangi persepsi warna.

Contoh penggunaan (lihat gambar B-E)

Contoh penggunaan alat ukur dapat dilihat pada halaman bergambar.

Perawatan dan servis

Perawatan dan pembersihan

Jaga kebersihan alat.

Jangan memasukkan alat pengukur ke dalam air atau cairan lainnya.

Jika alat kotor, bersihkan dengan lap yang lembut dan lembap. Jangan gunakan bahan pembersih atau zat pelarut. Bersihkanlah secara berkala terutama permukaan outlet sinar laser dan pastikan terbebas dari bulu halus.

Simpan dan lakukan pengangkutan pada alat ukur hanya di dalam tas pelindung (23).

Kirim alat ukur dalam tas pelindung (23) saat hendak dilakukan reparasi.

Layanan pelanggan dan konsultasi penggunaan

Layanan pelanggan Bosch menjawab semua pertanyaan Anda tentang reparasi dan perawatan serta tentang suku cadang produk ini. Gambaran teknis (exploded view) dan informasi mengenai suku cadang dapat ditemukan di:

www.bosch-pt.com

Tim konsultasi penggunaan Bosch akan membantu Anda menjawab pertanyaan seputar produk kami beserta aksesorinya.

Jika Anda hendak menanyakan sesuatu atau memesan suku cadang, selalu sebutkan nomor model yang terdiri dari 10 angka dan tercantum pada label tipe produk.

Indonesia

PT Robert Bosch
Palma Tower 10th Floor
Jalan RA Kartini II-S Kaveling 6
Pondok Pinang, Kebayoran Lama
Jakarta Selatan 12310
Tel.: (021) 3005 5800
Fax: (021) 3005 5801
E-Mail: boschpowertools@id.bosch.com
www.bosch-pt.co.id

Alamat layanan lainnya dapat ditemukan di:

www.bosch-pt.com/serviceaddresses

Cara membuang

Alat ukur, aksesori, dan kemasan harus didaur ulang dengan cara yang ramah lingkungan.



Jangan membuang alat ukur dan baterai bersama dengan sampah rumah tangga!

Tiếng Việt

Hướng dẫn an toàn



Phải đọc và chú ý mọi hướng dẫn để đảm bảo an toàn và không bị nguy hiểm khi làm việc với dụng cụ đo. Khi sử dụng dụng cụ đo không phù hợp với các hướng dẫn ở trên, các thiết bị bảo vệ được tích hợp trong dụng cụ đo

có thể bị suy giảm. Không bao giờ được làm cho các dấu hiệu cảnh báo trên dụng cụ đo không thể đọc được. **HÃY BẢO QUẢN CÁN THẬN CÁC HƯỚNG DẪN NÀY VÀ ĐƯA KÈM THEO KHI BẠN CHUYỂN GIAO DỤNG CỤ ĐO.**

- ▶ **Thận trọng** - nếu những thiết bị khác ngoài thiết bị hiệu chỉnh hoặc thiết bị điều khiển được nêu ở đây được sử dụng hoặc các phương pháp khác được tiến hành, có thể dẫn đến phơi nhiễm phóng xạ nguy hiểm.
- ▶ **Máy đo được dán nhãn cảnh báo laser** (được đánh dấu trong mô tả máy đo ở trang đồ thị).
- ▶ **Nếu văn bản của nhãn cảnh báo laser không theo ngôn ngữ của bạn, hãy dán chống nhãn dính được cung cấp kèm theo bằng ngôn ngữ của nước bạn lên trên trước khi sử dụng lần đầu tiên.**



Không được hướng tia laser vào người hoặc động vật và không được nhìn vào tia laser trực tiếp hoặc phản xạ. Bởi vì bạn có thể chiếu lóa mắt người, gây tai nạn hoặc gây hỏng mắt.

- ▶ **Nếu tia laser hướng vào mắt, bạn phải nhắm mắt lại và ngay lập tức xoay đầu để tránh tia laser.**
- ▶ **Không thực hiện bất kỳ thay đổi nào ở thiết bị laser.**
- ▶ **Không sử dụng kính nhìn tia laser (Phụ kiện) làm kính bảo vệ.** Kính nhìn tia laser dùng để nhận biết tốt hơn tia laser; tuy nhiên kính không giúp bảo vệ mắt khỏi tia laser.
- ▶ **Không sử dụng kính nhìn tia laser (Phụ kiện) làm kính mát hoặc trong giao thông đường bộ.** Kính nhìn tia laser không chống UV hoàn toàn và giảm thiểu thụ cảm màu sắc.
- ▶ **Chỉ để người có chuyên môn được đào tạo sửa dụng cụ đo và chỉ dùng các phụ tùng gốc để sửa chữa.** Điều này đảm bảo cho sự an toàn của dụng cụ đo được giữ nguyên.
- ▶ **Không để trẻ em sử dụng dụng cụ đo laser khi không có người lớn giám sát.** Có thể vô tình làm lóa mắt người khác hoặc làm lóa mắt chính bản thân.
- ▶ **Không làm việc với dụng cụ đo trong môi trường dễ nổ, mà trông đó có chất lỏng, khí ga hoặc bụi dễ cháy.** Các tia lửa có thể hình thành trong dụng cụ đo và có khả năng làm rách cháy hay ngùn khói.



Không để dụng cụ đo và phụ kiện từ tính ở gần mô cấy và các thiết bị y tế khác, ví dụ như máy trợ tim hoặc bơm insulin. Từ tính của dụng cụ đo và phụ kiện có thể tạo ra một trường ảnh hưởng xấu đến chức năng của mô cấy và các thiết bị y tế.

- ▶ **Để dụng cụ đo và phụ kiện từ tính tránh xa các phương tiện nhớ từ tính và các thiết bị**

nhạy từ. Ảnh hưởng của từ tính từ dụng cụ đo và phụ kiện có thể gây mất dữ liệu không phục hồi được.

Mô Tả Sản Phẩm và Đặc Tính Kỹ Thuật

Xin lưu ý các hình minh họa trong phần trước của hướng dẫn vận hành.

Sử dụng đúng cách

Dụng cụ đo được thiết kế để xác định và kiểm tra các đường ngang và dọc cũng như các điểm vuông góc.

Dụng cụ đo thích hợp để sử dụng trong nhà.

Các bộ phận được minh họa

Sự đánh số các biểu trưng của sản phẩm là để tham khảo hình minh họa dụng cụ đo trên trang hình ảnh.

- (1) Cửa chiếu luồng laser
- (2) Lẫy cài nắp đập pin
- (3) Nắp đập pin
- (4) Mã seri sản xuất
- (5) Nhãn cảnh báo laser
- (6) Rãnh ghép của dụng cụ đo
- (7) Công tắc Tắt/Mở
- (8) Ống nivô của đế xoay
- (9) Điểm nhận giá đỡ ba chân 5/8" của đế xoay
- (10) Vít điều chỉnh cao độ của đế xoay
- (11) Vít tinh chỉnh của đế xoay
- (12) Đế xoay
- (13) Rãnh ghép của đế xoay
- (14) Hiển thị cơ cấu khóa con lắc
- (15) Hiển thị trạng thái
- (16) Núm vận hành dọc
- (17) Núm vận hành ngang
- (18) Bộ chuyển đổi giá đỡ ba chân^{a)}
- (19) Giá ba chân 1/4"^{a)}
- (20) Kính nhìn tia laser^{a)}
- (21) Nam châm^{a)}
- (22) Bảng đích tia laser^{a)}
- (23) Túi xách bảo vệ
- (24) Giá ba chân 5/8"^{a)}

a) Phụ tùng được trình bày hay mô tả không phải là một phần của tiêu chuẩn hàng hóa được giao kèm theo sản phẩm. Bạn có thể tham khảo tổng thể các loại phụ tùng, phụ kiện trong chương trình phụ tùng của chúng tôi.

Thông số kỹ thuật

Máy laser đường vạch	GLL 3-15 X
Mã hàng	3 601 K63 M..
Phạm vi làm việc ^{A)}	
– Tia laser	15 m
– Điểm chuẩn	5 m
Cốt thủy chuẩn chính tia laser ^{B)(C)(D)}	±0,2 mm/m
Phạm vi tự cân bằng	±3°
Thời gian lấy cốt thủy chuẩn tiêu biểu	< 4 s
Nhiệt độ hoạt động	-10 °C ... +45 °C
Nhiệt độ lưu kho	-20 °C ... +70 °C
Chiều cao ứng dụng tối đa qua chiều cao tham chiếu	2000 m
Độ ẩm không khí tương đối tối đa.	90 %
Mức độ bền theo IEC 61010-1	2 ^{E)}
Cấp độ laser	2
Loại laser	< 1 mW, 630-650 nm
C _s	1
Phân kỳ	
– Tia laser	1,5 mrad
– Điểm chuẩn	1,5 mrad
Điểm nhận giá đỡ ba chân ^{F)}	5/8"
Bộ nguồn	4 × 1,5 VLR6 (AA)
Thời gian vận hành khoảng ^{G)}	
– Với 1 tia laser	24 h
– Với 2 tia laser	14 h
– Với 3 tia laser	10 h
Trong lượng theo Quy trình EPTA-Procedure 01:2014	0,54 kg
Kích thước (chiều dài × rộng × cao)	
– Không để xoay	122 × 83 × 129 mm
– Có để xoay	Ø 151 × 203 mm

Máy laser đường vạch**GLL 3-15 X**

Mức độ bảo vệ (không kể khoang chứa pin) IP 54 (được bảo vệ chống bụi và tia nước)

- A) Phạm vi làm việc có thể được giám thông qua các điều kiện môi trường không thuận lợi (ví dụ như tia mặt trời chiếu trực tiếp).
- B) Giao tại nhà máy
- C) ở **20–25 °C**
- D) Điều kiện là các giá trị đã đặt từ bình thường đến các điều kiện xung quanh phù hợp (ví dụ không rung, không sương mù, không khói, không tia cực tím trực tiếp). Sau khi có dao động nhiệt độ mạnh, có thể dẫn đến sai lệch độ chính xác.
- E) Chỉ có chất bán không dẫn xuất hiện, nhưng đôi khi độ dẫn điện tạm thời gây ra do ngưng tụ.
- F) Chỉ có sẵn khi kết hợp với đế xoay
- Số xeri **(4)** đều được ghi trên nhãn mác, để dễ dàng nhận dạng loại máy đo.

Sự lắp vào**Lắp/thay pin**

Khuyến nghị sử dụng các pin kiềm mangan để vận hành dụng cụ đo.

Để mở nắp đậy pin **(3)** bạn hãy nhấn lên khóa **(2)** và tháo nắp đậy pin ra. Lắp pin vào.

Xin hãy lưu ý lắp tương ứng đúng cực pin như được thể hiện mặt trong ngăn chứa pin.

Nếu màn hình hiển thị trạng thái nhấp nháy **(15)**, bạn cần thay pin.

Luôn luôn thay tất cả pin cùng một lần. Chỉ sử dụng pin cùng một hiệu và có cùng một điện dung.

► **Tháo ắc quy ra khỏi dụng cụ đo nếu bạn không muốn sử dụng thiết bị trong thời gian dài.** Pin có thể hư mòn sau thời gian bảo quản lâu trong dụng cụ đo và tự xả điện.

Làm việc với đế xoay (xem Hình A)

Với đế xoay **(12)** bạn có thể xoay dụng cụ đo 360° quanh một điểm chuẩn trung tâm thấy rõ. Nhờ đó, các tia Laser sẽ được thiết lập chính xác, mà không cần thay đổi vị trí của dụng cụ đo.

Đặt dụng cụ đo trên đế xoay **(12)**, sao cho rãnh ghép **(13)** của đế xoay khớp với rãnh ghép tương ứng **(6)** ở mặt dưới của dụng cụ đo. Xoay dụng cụ đo theo chiều kim đồng hồ để khóa nó trên đế xoay.

Tháo chân của đế xoay ra **(12)** với vít điều chỉnh chiều cao **(10)**.

Điều chỉnh sơ bộ đế xoay bằng ống nivô **(8)**.

Nếu máy đo được lắp trên đế xoay **(12)**, bạn có thể chỉnh hướng các tia laser thẳng đứng bằng vít tinh chỉnh **(11)** một cách chính xác tại các điểm tham chiếu.

Vận Hành

Bắt Đầu Vận Hành

- ▶ **Bảo vệ dụng cụ đo tránh khỏi ẩm ướt và không để bức xạ mặt trời chiếu trực tiếp vào.**
- ▶ **Không cho dụng cụ đo tiếp xúc với nhiệt độ khắc nghiệt hoặc dao động nhiệt độ.** Không để nó trong chế độ tự động quá lâu. Hãy cho điều chỉnh nhiệt độ cho dụng cụ đo khi dao động nhiệt độ lớn và luôn tiến hành kiểm tra độ chính xác trước khi làm việc tiếp (xem „Kiểm tra độ chính xác của dụng cụ đo“, Trang 44). Trong trường hợp ở trạng thái nhiệt độ cực độ hay nhiệt độ thay đổi thái quá, sự chính xác của dụng cụ đo có thể bị hư hỏng.
- ▶ **Tránh va chạm mạnh hoặc làm rơi dụng cụ đo.** Sau khi có tác động mạnh từ bên ngoài lên dụng cụ đo, cần tiến hành kiểm tra độ chính xác trước khi tiếp tục (xem „Kiểm tra độ chính xác của dụng cụ đo“, Trang 44).
- ▶ **Hãy tắt dụng cụ đo, khi bạn vận chuyển.** Khi tắt máy, bộ phận lấy cốt thủy chuẩn được khóa lại, bộ phận này có thể bị hư hỏng trong trường hợp bị di chuyển cực mạnh.

Bật Mở và Tắt

Để **bật** dụng cụ đo, hãy trượt nút bật/tắt (7) vào vị trí „**On**“ (để vận hành với cơ cấu khóa con lắc) hoặc vào vị trí „**On**“ (để vận hành với chức năng lấy cốt thủy chuẩn tự động). Hiện thị trạng thái (15) sẽ chiếu sáng. Sau khi bật, dụng cụ đo ngay lập tức phát tia laser ngang từ cửa chiếu phía trước (1).

▶ **Không được chứa luồng laser vào con người hay động vật và không được tự chính bạn nhìn vào luồng laser, ngay cả khi từ một khoảng cách lớn.**

Để **tắt** máy đo hãy trượt nút bật/tắt (7) ở vị trí "Off". Hiện thị trạng thái (15) sẽ tắt. Khi tắt, trạm con lắc được khóa.

- ▶ **Không cho phép dụng cụ đo đang bật một cách không kiểm soát và hãy tắt dụng cụ đo sau khi sử dụng.** Tia Laser có thể chiếu vào những người khác.

Nếu vượt quá nhiệt độ cao nhất cho phép là 45 °C, dụng cụ sẽ tắt để bảo vệ di-ốt laser. Sau khi nguội trở lại, dụng cụ đo ở trạng thái sẵn sàng hoạt động và ta có thể mở máy để hoạt động trở lại.

Khử Hoạt Chức Năng Tắt Tự Động

Máy đo tự tắt sau 30 phút thời gian vận hành.

Để tắt chế độ tự động ngắt, bạn hãy giữ nút chế độ vận hành dọc (16) hoặc nút chế độ vận hành ngang (17) khi đang bật máy trong 3 giây. Khi ngưng chế độ tự động tắt, tia laser sẽ nhấp nháy nhanh chóng sau 3 giây.

Để kích hoạt tắt tự động, bạn hãy tắt máy đo và bật lên lần nữa (không cần nhấn nút).

Chế độ hoạt động

Dụng cụ đo có một vài chế độ vận hành mà bạn có thể chuyển đổi qua lại bất cứ khi nào. Vận hành ngang và dọc có thể được tắt và bật mà không phụ thuộc với nhau. Sau khi mở máy, dụng cụ đo nằm ở chế độ vận hành ngang.

Tất cả chế độ hoạt động đều có thể được chọn với Chế độ tự động cân bằng và với cơ cấu khóa con lắc.

Chế độ vận hành ngang (xem Hình B)

Trong chế độ vận hành ngang, dụng cụ đo phát ra một tia laser nằm ngang về phía trước.

Để tắt hoặc bật tia laser nằm ngang, bạn nhấn nút chế độ vận hành ngang (17).

Chế độ vận hành dọc và điểm chuẩn (xem Hình C–D)

Dụng cụ đo có hai chế độ vận hành dọc:

- tia laser dọc hướng về phía trước,
- tia laser dọc hướng về phía trước và sang bên phải.

Ngoài ra, điểm chuẩn luôn được chiếu xuống dưới trong chế độ vận hành dọc.

Để bật hoặc tắt vận hành dọc cũng như để thay đổi chế độ vận hành dọc, bạn nhấn nút vận hành dọc (16) liên tục, cho tới khi đạt chế độ vận hành mong muốn.

Lấy Cốt Thủy Chuẩn Tự Động

Vận Hành với Chức Năng Lấy Cốt Thủy Chuẩn Tự Động

Bạn hãy đặt dụng cụ đo lên một mặt nền cố định, nằm ngang hoặc cố định máy trên đế xoay (12).

Bạn hãy trượt nút bật/tắt vào (7) vào vị trí "On" để làm việc với tự động cân bằng.

Chế độ tự động cân bằng sẽ tự động điều chỉnh bằng phẳng trong phạm vi tự cân bằng từ $\pm 3^\circ$. Việc cân bằng được hoàn tất, ngay khi các tia laser không còn bị di chuyển.

Nếu không thể tự động lấy cốt thủy chuẩn, ví dụ vì bề mặt đặt dụng cụ đo bị dốc hơn 3° so với bề mặt bằng phẳng, vạch laser nhấp nháy.

Trong trường hợp này, đưa dụng cụ đo về vị trí bằng phẳng và đợi cho sự tự lấy cốt thủy chuẩn diễn ra. Ngay khi máy đo nằm trong phạm vi tự cân bằng $\pm 3^\circ$, các tia laser phát sáng ổn định và âm tín hiệu được tắt.

Khi có rung động hoặc thay đổi vị trí trong lúc vận hành, dụng cụ đo sẽ tự động cân bằng trở lại. Để tránh lỗi do sự di chuyển dụng cụ đo, hãy kiểm tra vị trí của luồng laser, đối chiếu với điểm xuất phát chuẩn trong khi lấy lại cốt thủy chuẩn lần nữa.

Vận Hành với cơ cấu khóa con lắc

Bạn hãy trượt nút bật/tắt vào (7) vào vị trí „**On**“ để làm việc với cơ cấu khóa con lắc. Hiện thị cơ

cấu khóa con lắc (14) bật sáng màu đỏ và tia laser nhấp nháy liên tục theo nhịp chậm.

Khi vận hành với cơ cấu khóa con lắc, chế độ tự động cân bằng được tắt. Bạn có thể tự do cầm dụng cụ đo theo mọi cách trong tay hay đặt trên một bề mặt nghiêng. Các tia laser không còn được cân bằng và không còn hoạt động theo chiều thẳng đứng đối xứng nhau nữa.

Kiểm tra độ chính xác của dụng cụ đo

Những Ảnh Hưởng Đến độ Chính xác

Nhiệt độ chung quanh có ảnh hưởng lớn nhất. Đặc biệt là sự sai biệt của nhiệt độ xảy ra từ mặt đất hướng lên có thể làm lệch hướng luồng laze.

Vì phân tầng nhiệt độ ở gần mặt đất là cao nhất, bạn nên đặt dụng cụ đo lên giá đỡ ba chân nếu có thể và đặt nó ở chính giữa bề mặt thao tác.

Bên cạnh các tác động ngoài, các tác động ảnh hưởng trực tiếp tới thiết bị (như rơi hoặc va đập mạnh) có thể gây ra các sai lệch. Do đó, hãy kiểm tra mức độ chính xác trước khi bắt đầu công việc.

Trước tiên bạn hãy kiểm tra tương ứng chiều cao cũng như độ chính xác cân bằng của vạch laze nằm ngang, sau đó là của vạch nằm dọc.

Nếu giá như dụng cụ đo lệch hướng vượt mức tối đa tại một trong những lần kiểm tra, xin vui lòng mang đến trạm phục vụ hàng đã bán của **Bosch** để được sửa chữa.

Kiểm tra chiều cao chính xác của vạch nằm ngang

Để kiểm tra, bạn cần một đoạn đo thoáng dài 5 m trên mặt nền vững chắc giữa tường A và B.

- Gắn dụng cụ đo gần tường A lên trên đế xoay (12) hoặc giá đỡ ba chân (24), hoặc để nó trên nền bằng phẳng, vững chắc. Bạn hãy bật máy đo vận hành với tự động cân bằng. Bật chế độ vận hành ngang và chế độ vận hành dọc với một tia laser về trước.

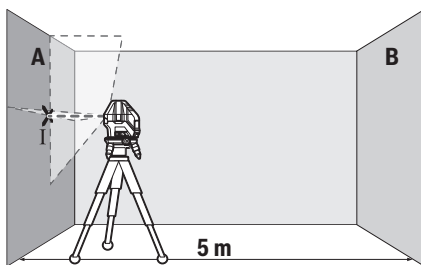

- Hướng thẳng luồng laze vào tường A gần bên và để dụng cụ đo chiếu vào. Đánh dấu điểm giữa của điểm giao nhau của các tia laser trên bức tường (điểm I).

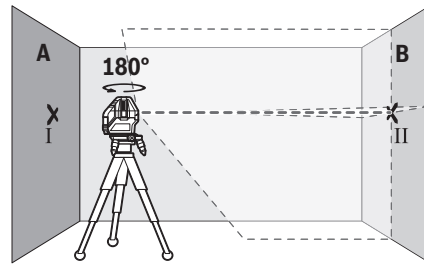

- Hãy xoay dụng cụ đo 180°, để dụng cụ đo cân bằng và đánh dấu điểm giao nhau của tia laser ở tường đối diện B (điểm II).
- Hãy đặt dụng cụ đo – mà không xoay – gần tường B, hãy bật và để dụng cụ cân bằng.

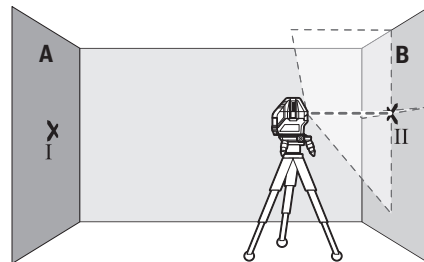

- Hãy căn chỉnh dụng cụ đo ở mức độ cao (nhờ giá đỡ ba chân hoặc bằng cách đặt xuống dưới nếu cần) sao cho điểm giao nhau của tia laser gặp điểm đã đánh dấu trước đó II trên tường B.

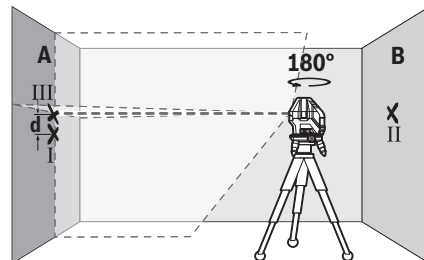

- Xoay dụng cụ đo 180° mà không thay đổi chiều cao. Hãy hướng nó lên tường A sao cho tia laser dọc chạy qua điểm đã đánh dấu I. Hãy để dụng cụ đo cân bằng và đánh dấu điểm giao nhau của tia laser trên tường A (điểm III).
- Sự chênh lệch d của cả hai điểm đã đánh dấu I và III trên tường A dẫn đến lệch chiều cao thực tế của dụng cụ đo.

Trên đoạn đường đo $2 \times 5 \text{ m} = 10 \text{ m}$, biên độ chênh lệch cho phép tối đa là: $10 \text{ m} \times \pm 0,2 \text{ mm/m} = \pm 2 \text{ mm}$. Do đó, chênh lệch d giữa điểm I và III được phép cao nhất là 2 mm.

Kiểm tra cốt thủy chuẩn chính xác của vạch nằm ngang

Để kiểm tra, bạn cần một mặt phẳng thoáng khoảng 5×5 m.

- Hãy lắp máy đo ở điểm giữa hai bức tường A và B trên đế xoay (12) hoặc giá đỡ ba chân (24), hoặc để nó trên nền bằng phẳng, vững chắc. Bạn hãy bật máy đo vận hành với tự động cân bằng. Bật chế độ vận hành ngang và để dụng cụ đo cân bằng.

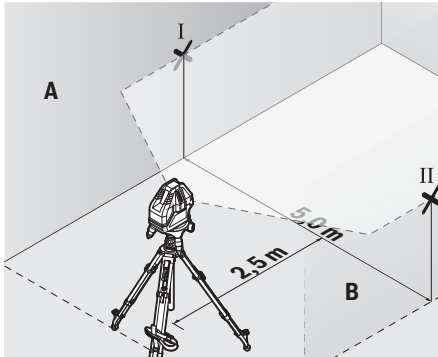

- Hãy đánh dấu tâm điểm của vạch laze cách xa dụng cụ đo 2,5 m ở cả hai thành (điểm I trên thành A và điểm II trên thành B).

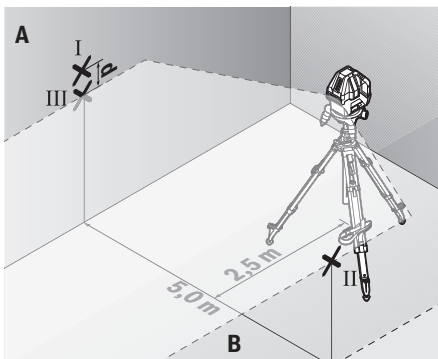

- Đặt dụng cụ đo xoay 180° cách xa 5 m và để nó tự cân bằng.
- Căn chỉnh chiều cao của dụng cụ (nhờ giá đỡ ba chân hoặc đặt nằm) sao cho tâm điểm của vạch laze chạm đúng vào điểm II đã được đánh dấu sẵn trên thành B.
- Hãy đánh dấu tâm điểm của vạch laze làm điểm III (thẳng đứng trên hoặc dưới điểm I) trên thành A.
- Chênh lệch d của cả hai điểm I và III đã được đánh dấu trên thành A chính là độ lệch thực tế của dụng cụ đo ở phương ngang.

Trên đoạn đường đo $2 \times 5 \text{ m} = 10 \text{ m}$, biên độ chênh lệch cho phép tối đa là:

$10 \text{ m} \times \pm 0,2 \text{ mm/m} = \pm 2 \text{ mm}$. Do đó, chênh lệch d giữa điểm I và III được phép cao nhất là 2 mm.

Kiểm tra cốt thủy chuẩn chính xác của mực thẳng đứng

Đối với kiểm tra loại này, khung cửa trống cần mỗi bên cửa rộng ít nhất là 2,5 m (trên một bề mặt ổn định).

- Đặt máy cách cửa mở 2,5 m trên nền bằng phẳng, vững chắc (không dựng trên (12) hoặc giá ba chân). Bạn hãy bật máy đo vận hành với tự động cân bằng. Bật vận hành dọc với một tia laser thẳng đứng hướng về trước và chỉnh hướng tia laser vào cửa mở. Hãy để máy cân bằng.

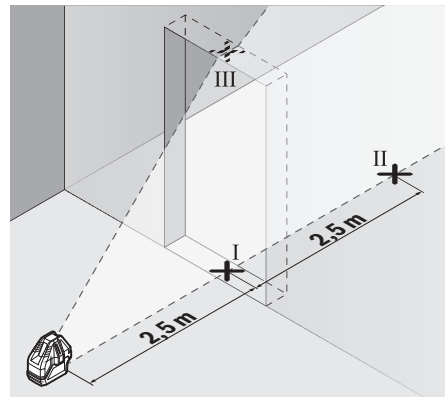

- Hãy đánh dấu điểm giữa của tia laser dọc trên sàn của khung cửa trống (điểm I), ở khoảng cách 5 m ở phía còn lại của khung cửa trống (điểm II) cũng như ở mép trên của khung cửa trống (điểm III).

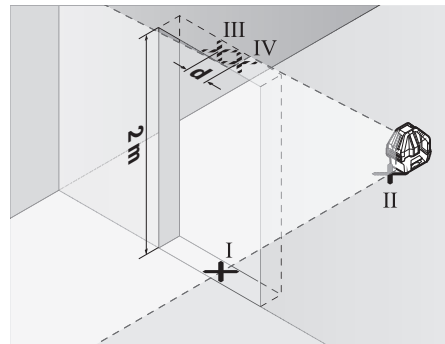

- Hãy xoay dụng cụ đo 180° và đặt nó trên phía còn lại của khung cửa trống ngay sau điểm II. Hãy để dụng cụ đo cân bằng và hướng tia laser dọc sao cho điểm giữa của nó chạy qua điểm I và II.
- Hãy đánh dấu điểm giữa của tia laser trên mép của khung cửa trống làm điểm IV.

- Sự chênh lệch **d** của cả hai điểm đã đánh dấu III và IV dẫn đến độ lệch thực tế của dụng cụ đo so với phương thẳng đứng.

– Đo chiều cao của khung cửa trống.

Hãy tính độ lệch cho phép tối đa như sau:

hai lần chiều cao của cửa mở $\times 0,2$ mm/m

Ví dụ: Khi chiều cao của cửa mở là 2 m, độ chênh lệch tối đa là

$2 \times 2 \text{ m} \times \pm 0,2 \text{ mm/m} = \pm 0,8 \text{ mm}$. Các điểm III và IV được phép cách nhau nhiều nhất là **0,8** mm.

Hướng Dẫn Sử Dụng

- **Chỉ luôn sử dụng tâm của điểm laser hoặc tia laser để đánh dấu.** Kích thước của tiêu điểm laser cũng như bề rộng của tia laser thay đổi theo khoảng cách.

Sử dụng cùng với tấm cọc tiêu laze

Bảng đích laze (22) cải thiện độ rõ của tia laser ở những điều kiện không phù hợp và ở khoảng cách lớn.

Bề mặt phản chiếu của bảng đích laser (22) cải thiện độ rõ của tia laser, thông qua bề mặt trong suốt, tia laser của mặt sau bảng đích laser cũng có thể được phát hiện.

Làm việc với giá đỡ ba chân (phụ kiện) (xem Hình F)

Giá đỡ ba chân cung cấp khả năng đo ổn định và linh hoạt. Để gắn dụng cụ đo lên giá đỡ ba chân, hãy đặt dụng cụ đo lên đế xoay (12).

Gắn trên giá đỡ ba chân 5/8": Đặt đế xoay với điểm nhận giá đỡ ba chân 5/8" (9) lên ren của giá đỡ ba chân 5/8" (24) hoặc của một giá đỡ ba chân thông thường. Vặn chặt đế xoay bằng vít cố định của giá đỡ ba chân.

Gắn trên giá đỡ ba chân 1/4" (xem Hình F): Vặn chặt bộ chuyển đổi giá đỡ ba chân (18) (phụ kiện) vào điểm nhận giá ba chân 5/8" (9) của đế xoay. Đặt bộ chuyển đổi giá ba chân có điểm nhận cỡ 1/4" lên ren của giá đỡ ba chân 1/4" (19) hoặc của một giá đỡ máy ảnh thông thường. Vặn chặt bộ chuyển đổi giá đỡ ba chân bằng vít cố định của giá đỡ ba chân.

Điều chỉnh sơ giá đỡ trước khi cho dụng cụ đo hoạt động.

Kính nhìn laser (phụ kiện)

Kính nhìn laser sẽ lọc nguồn ánh sáng xung quanh. Do đó ánh sáng của laser sẽ sáng hơn đối với mắt.

- **Không sử dụng kính nhìn tia laser (Phụ kiện) làm kính bảo vệ.** Kính nhìn tia laser dùng để nhận biết tốt hơn tia laser; tuy nhiên kính không giúp bảo vệ mắt khỏi tia laser.
- **Không sử dụng kính nhìn tia laser (Phụ kiện) làm kính mát hoặc trong giao thông đường bộ.** Kính nhìn tia laser không chống UV hoàn toàn và giảm thiểu thụ cảm màu sắc.

Công việc theo Thí dụ (Xem Hình ảnh B–E)

Các ứng dụng mẫu cho dụng cụ đo có thể tra cứu trên các trang hình ảnh.

Bảo Dưỡng và Bảo Quản

Bảo Dưỡng Và Làm Sạch

Luôn luôn giữ cho dụng cụ đo thật sạch sẽ.

Không được nhúng dụng cụ đo vào trong nước hay các chất lỏng khác.

Lau sạch bụi bẩn bằng một mảnh vải mềm và ẩm. Không được sử dụng chất tẩy rửa.

Thường xuyên lau sạch bề mặt các cửa chiếu laze một cách kỹ lưỡng, và lưu ý đến các tựa vải hay sợi chỉ.

Chỉ bảo quản và vận chuyển dụng cụ đo trong túi bảo vệ (23).

Trong trường hợp cần sửa chữa, hãy gửi dụng cụ đo trong túi bảo vệ (23).

Dịch vụ hỗ trợ khách hàng và tư vấn sử dụng

Bộ phận phục vụ hàng sau khi bán của chúng tôi trả lời các câu hỏi liên quan đến việc bảo dưỡng và sửa chữa các sản phẩm cũng như phụ tùng thay thế của bạn. Sơ đồ mô tả và thông tin về phụ tùng thay thế cũng có thể tra cứu theo dưới đây:

www.bosch-pt.com

Đội ngũ tư vấn sử dụng của Bosch sẽ giúp bạn giải đáp các thắc mắc về sản phẩm và phụ kiện.

Trong tất cả các phản hồi và đơn đặt phụ tùng, xin vui lòng luôn luôn nhập số hàng hóa 10 chữ số theo nhãn của hàng hóa.

Việt Nam

CN CÔNG TY TNHH BOSCH VIỆT NAM TẠI TP.HCM

Tầng 14, Ngõ Nhà Đức, 33 Lê Duẩn

Phường Bến Nghé, Quận 1, Thành Phố Hồ Chí Minh

Tel.: (028) 6258 3690

Fax: (028) 6258 3692 - 6258 3694

Hotline: (028) 6250 8555

Email: tuvankhachhang-pt@vn.bosch.com

www.bosch-pt.com.vn

www.baohanhbosch-pt.com.vn

Xem thêm địa chỉ dịch vụ tại:

www.bosch-pt.com/serviceaddresses

Sự thải bỏ

Dụng cụ đo, phụ kiện và bao bì phải được phân loại để tái chế theo hướng thân thiện với môi trường.



Không vứt dụng cụ đo và pin cùng trong rác thải của gia đình!